

Jøtul GZ 550 DV II Acadia
Direct Vent Gas Fireplace

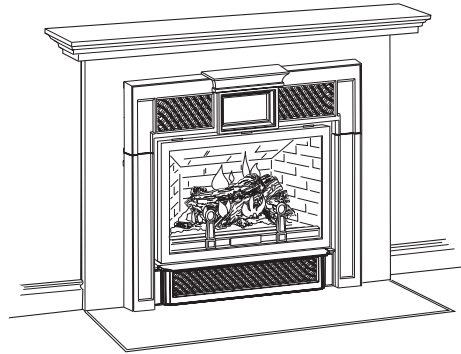

Installation and Operation Instructions

WARNING: If the information in these instructions is not followed exactly, a fire or explosion may result causing property damage, personal injury or death.

- Do not store or use gasoline or other flammable vapors and liquids in the vicinity of this or any other appliance.
- **WHAT TO DO IF YOU SMELL GAS**
 - Do not try to light any appliance.
 - Do not touch any electrical switch; do not use any phone in your building.
 - Immediately call you gas supplier from a neighbor's phone. Follow the gas supplier's instruction.
 - If you cannot reach your gas supplier, call the fire department.
- Installation and service must be performed by a qualified installer, service agency or the gas supplier.
- A carbon monoxide (CO) detector shall be installed in the same room as the appliance.

AVERTISSEMENT: Assurez-vous de bien suivre les instructions données dans cette notice pour réduire au minimum le risque d'incendie ou d'explosion ou pour éviter tout dommage matériel, toute blessure ou la mort.

- Ne pas entreposer ni utiliser d'essence ni d'autres vapeurs ou liquides inflammables dans le voisinage de cet appareil ou de tout autre appareil.
- **QUE FAIRE SI VOUS SENTEZ UNE ODEUR DE GAZ:**
 - Ne pas tenter d'allumer l'appareil.
 - Ne touchez à aucun interrupteur. Ne pas vous servir des téléphones se trouvant dans le bâtiment où vous trouvez.
 - Appelez immédiatement votre fournisseur de gaz depuis un voisin. Suivez les instructions du fournisseur.
 - Si vous ne pouvez rejoindre le fournisseur de gaz, appelez le service des incendies.
- L'installation et l'entretien doivent être assurés par un installateur ou un service d'entretien qualifié ou par le fournisseur de gaz.



Welcome to Jøtul...

Congratulations on the purchase of your new Jøtul GZ 550 DV II Acadia Gas Fireplace.

We at Jøtul are glad you've made the decision to warm your hearth with a Jøtul product. Your new fireplace exemplifies our experience gained over 150 years as the world's largest manufacturer of solid fuel burning appliances. We've been making fine quality cast iron wood and coal stoves and fireplaces continuously since 1853.

The Jøtul GZ550 DV II Acadia fireplace combines advanced gas technology with the warm, traditional elements of cast iron. With proper care and use, your fireplace will provide you with many years of safe, dependable and satisfying service.

The Jøtul GZ550 DV II Acadia is a direct vented gas heater designed and approved for installation into a variety of configurations where close clearance to combustible material is required. Please take a few minutes to familiarize yourself with this manual and the features of your new Jøtul fireplace.



Table of Contents

Specifications 4

Installation / Service Tools 5

General Information 5

Safety Information 6

Installation Requirements

 Framing 6

 Mantel Clearances 8

 Hearth Protection 8

 Vent Requirements 9

 Vertical Termination 10

 Horizontal Termination 11

 Terminal Clearances 11

 Vent Restrictor 12

Fireplace Assembly

 Blower Installation 12

 Gas Connection 14

 Gas Pressure 14

 High Altitude Adjustment 15

 Fuel Conversion 16

 Wall Thermostat 19

 Remote Control 19

 Antique Brick Kit 20

 Log Set Installation 21

 Surround Assembly 22

 Double Door Installation 22

 System Check 23

Operation 25

Maintenance 26

Glass Replacement 26

Service Log 27

Illustrated Parts Breakdown 28

Replacement Parts List 29

Accessories 30

Lighting Instructions Back Cover

Unpacking the Fireplace

1. Before you remove the carton, remove the cast iron parts that are packed around the fireplace cabinet.

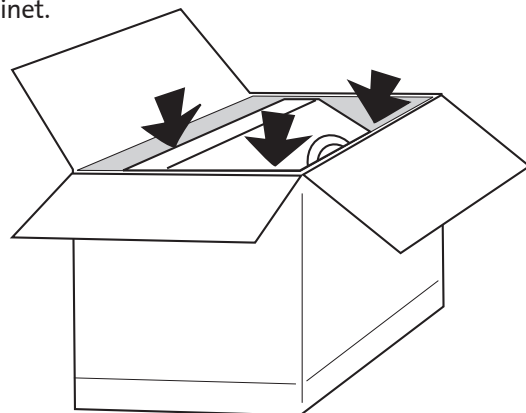

2. Lift the shipping carton off of the fireplace cabinet.

3. Unpack the Firebox. The Logset is packaged inside the firebox. Remove the Glass Panel Frame to unpack the firebox:

- Locate the right and left spring latches on the underside of the firebox floor. Release each latch by pulling them forward to disengage the frame body.
- Pull the Glass Frame away from the firebox and lift to disengage it from the three steel tabs located at the top of the firebox. Set the glass out of the way.

Do not unpack the logs until you are ready to install them.

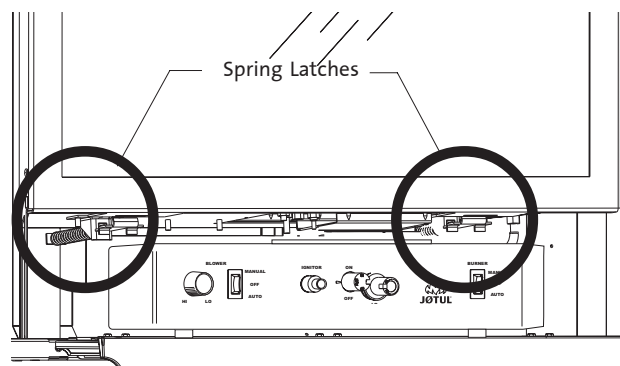

Pull each Spring Latch to disengage them from the Glass Frame.

PLEASE READ THESE INSTRUCTIONS IN THEIR ENTIRETY AND MAKE THEM AVAILABLE TO ANYONE USING OR SERVICING THIS APPLIANCE.

Jøtul GZ 550 DV II Acadia Direct Vent Gas Fireplace

Manufactured and Distributed by:
Jøtul A.S.A.
Fredrikstad, Norway
Jøtul North America
Gorham, Maine
M.E.A. No. 369-00-E

Test Standards

This appliance complies with National Safety standards and is tested and listed by Intertek Testing Services of Middleton, Wisconsin to ANSI Z21.88-2002 • CSA 2.33-M02 and CAN/CGA 2.17--M91, CSA P4.-01.2 for Canada.



DO NOT ATTEMPT TO ALTER OR MODIFY THE CONSTRUCTION OF THE APPLIANCE OR ITS COMPONENTS. ANY MODIFICATION OR ALTERATION WILL VOID THE WARRANTY, CERTIFICATION AND LISTING OF THIS APPLIANCE.

Specifications

Input Rates

Natural Gas

28,000 BTU/hr. maximum input
16,000 BTU/hr. minimum input

Propane

28,000 BTU/hr. maximum input
15,500 BTU/hr. minimum input

Inlet Pressure:	<u>MIN</u>	<u>MAX</u>
Natural Gas:	5.0 WC (1.24 kPa)	11.0 WC (2.74 kPa)
Propane:	12.0 WC (2.98 kPa)	14.9.0 WC (3.71 kPa)

Manifold Pressure:	<u>MIN</u>	<u>MAX</u>
Natural Gas:	1.2 WC (.29 kPa)	3.8 WC (.94 kPa)
Propane:	2.9 WC (.72 kPa)	11.0 WC (2.74 kPa)

THIS FIREPLACE IS SHIPPED AS A **NATURAL GAS** FIREPLACE ONLY. IF USE WITH PROPANE IS DESIRED, THE FIREPLACE MUST BE CONVERTED TO USE WITH PROPANE. FOR YOUR CONVENIENCE THIS FIREPLACE IS SHIPPED WITH A PROPANE CONVERSION KIT.

THIS HEATER MUST BE INSTALLED AND MAINTAINED BY A QUALIFIED SERVICE AGENCY.

IN THE COMMONWEALTH OF MASSACHUSETTS, THIS PRODUCT MUST BE INSTALLED BY A LICENSED PLUMBER OR GAS-FITTER.

DO NOT ATTEMPT TO ALTER OR MODIFY THE CONSTRUCTION OF THIS APPLIANCE OR ITS COMPONENTS. ANY MODIFICATION OR ALTERATION WILL VOID THE WARRANTY, CERTIFICATION AND LISTING OF THIS APPLIANCE.

**NATIONAL
FIREPLACE
INSTITUTE®**



CERTIFIED

www.nficertified.org

We recommend that our gas hearth products be installed and serviced by professionals who are certified in the U.S. by the National Fireplace Institute® (NFI) as NFI Gas Specialists.

General Information

IMPORTANT:
SAVE THESE INSTRUCTIONS.

THIS HEATER MUST BE INSTALLED AND MAINTAINED BY A QUALIFIED SERVICE AGENCY.

DO NOT ATTEMPT TO ALTER OR MODIFY THE CONSTRUCTION OF THIS APPLIANCE OR ITS COMPONENTS. ANY MODIFICATION OR ALTERATION WILL VOID THE WARRANTY, CERTIFICATION AND LISTING OF THIS APPLIANCE.

1. The installation and repair of this appliance must be done by a qualified service person. Failure to properly install and maintain this heater could result in an unsafe or hazardous installation, which may result in a fire, explosion, property damage, personal injury or loss of life.

2. This appliance should be inspected before use and at least annually. More frequent cleaning may be required due to excessive lint from carpeting, bedding material, etc. It is imperative that control compartments, burners and circulating air passageways of the appliance be kept clean.

Assurer que le bruleur et le compartiment des commandes sont propres. Voir les instructions d'installation et d'utilisation qui accompagnent l'appareil.

3. The installation must conform to local codes. Your local Jøtul authorized dealer can assist you in determining what is required in your area for a safe and legal installation. Some areas require a permit to install a gas burning appliance. Always consult your local building inspector or authority having jurisdiction to determine what regulations apply in your area.

In the absence of local codes, the installation requirements must comply with the current National codes. In the U.S., these requirements are established in the National Fuel Code, ANSI Z223.1.(NFPA 54). In Canada, the codes have been established in CAN/CGA B149 Fuel Installation Code.

Installer l'appareil selon les codes ou reglements locaux, ou, en l'absence de tels reglements, selon les Codes d'installation CAN/CGA-B149.

4. DO NOT OPERATE THIS FIREPLACE IF ANY PART

HAS BEEN UNDER WATER.

Immediately call a qualified service technician to inspect the heater and to replace any part of the control system and any gas control which has been under water.

Ne pas se servir de cet appareil s'il a ete' plonge dans l'eau, completement ou en partie. Appeler un technicien qualifie pour inspecter l'appareil et remplacer toute partie du syste'me de controle et toute commande qui ont ete plonges dans l'eau.

5. Do not operate the fireplace with the glass front removed, cracked or broken. Replacement of the glass should be done by a licensed or qualified service person. Only remove glass for routine service. Always handle glass carefully.

Pour utilisation avec les portes en verre cerifiers avec l'appareil seulement ou. Ne pas utiliser avec des portes en verre.

6. Notify your insurance company before proceeding with installation of this fireplace.

7. This appliance may be installed in an aftermarket permanently located, manufactured (mobile) home, where not prohibited by local codes. This appliance is only for use with the type(s) of gas indicated on the rating plate. This appliance is not convertible for use with other gases, unless a certified kit is used.

Cet appareil peut être installé dans un maison préfabriquée (mobile) déjà installée à demeure si les règlements locaux le permettent. Cet appareil doit être utilisé uniquement avec les types de gas indiqués sur la plaque signalétique. Ne pas l'utiliser avec d'autres gas sauf si un kit de conversion certifié est installé.

Suggested Tools for Installation and Service

- External regulator (for Propane only)
- Piping which complies with local code
- Manual shutoff valve - T-Handle in MA
- Sediment trap - if required by code
- 10mm open end wrench
- 1/2", 7/16" open end wrench
- Phillips head screwdriver
- Flat head screwdriver
- Tee joint
- Pipe wrench
- Pipe sealant
- 1/4" nut driver
- Torx T20 screwdriver
- Gloves
- Safety glasses
- Leak test solution
- Power Drill
- Reciprocating Saw

Safety Information

- Due to the high operating temperatures this appliance should be located out of traffic and away from furniture, draperies, etc. Maintain proper clearance to combustible mantels and fireplace trim.
- Children and adults should be alerted to the hazards of high surface temperatures and should stay away to avoid burns or clothing ignition.
- Young children should be supervised while they are in the same room as the Acadia gas fireplace. Surveiller les enfants. Garder les vêtements, les meubles, l'essence ou autres liquides a vapeur inflammables loin de l'appareil.
- Clothing or other flammable materials should not be placed ON or NEAR the Acadia gas fireplace.
- Never allow any to use the fireplace if they are unfamiliar with its operation.
- NEVER store or use gasoline or any other flammable vapors or liquids in the vicinity of the Acadia gas fireplace.
- Never burn any solid materials (wood, cardboard, paper, coal, etc.) in this gas fireplace. Use with natural gas or propane fuel ONLY.
- Any safety screen, glass or guard removed for servicing the appliance must be replaced prior to operating the appliance.
- Do not slam or strike the glass panel.
- Wear gloves and safety glasses while performing maintenance procedures.

Electrical Hazard

- Be aware of electrical wiring locations when cutting holes in walls and ceilings for termination.
- The optional Acadia Blower (155630) must be electrically grounded in accordance with local codes or, in the absence of local codes, with the current ANSI/NFPA 70, National Electrical Code or CSA C22.1-Canadian Electrical Code.
- The Acadia Blower is supplied with a three-prong (grounding) plug for protection against shock hazard and should be plugged directly into a properly grounded three-prong receptacle. DO NOT CUT OR REMOVE THE GROUNDING PRONG FROM THE PLUG.
- Always disconnect the power supply when performing routine service on the fireplace.

Installation Requirements

The GZ 550 DV Acadia Gas Fireplace and its vent system must be installed within a totally enclosed structure. The fireplace must be connected to the specified vent and termination cap outside the building. Do not vent into another room or inside any part of a building. **Under no circumstances may the flow of combustion or ventilation air be obstructed.**

The approved vent configurations described herein are derived from extensive testing under controlled laboratory conditions. Gas appliance performance can be negatively affected by variables present in the installation environment, i.e: strong prevailing winds, steep roofs, nearby trees, snow accumulation, etc. These conditions should be taken into consideration by the installer and home owner. In such instances, system performance can often be improved by an increase in the vent height or installation of a high wind termination cap.

Placement and Framing

The combustible framing members of the fireplace enclosure may be placed in direct contact with the fireplace cabinet as specified in the illustrations on the following pages. Use the standoffs integrated into the sides and top of the front opening to locate a combustible header and side framing members as shown in the illustrations. See fig. 1.

Electrical Power: If the optional Blower (#155630) will be used, be sure to include provision for a properly grounded, 120 volt house current outlet at the fireplace structure.

Parallel Installation

Although it is possible to place combustible framing members in direct contact with the rear surface of the cabinet, **the fireplace must be located forward of the back wall with adequate clearance to accommodate the vent adaptor and subsequent lengths of vent pipe.** Consideration must also be given to maintaining a minimum 1 inch (25 mm) clearance between a vertical vent pipe and any combustible materials to the rear of the unit. See Figs. 2, 3, and 4.

Corner Installation

A corner installation will require that the Vent Adaptor be installed in a top exit position. Horizontal terminations will then require use of a 90° elbow. Figs. 5 and 5a show rear termination with 5/8 Simpson Dura-Vent Wall Thimble #1247.

Figure 1. Cabinet Dimensions.

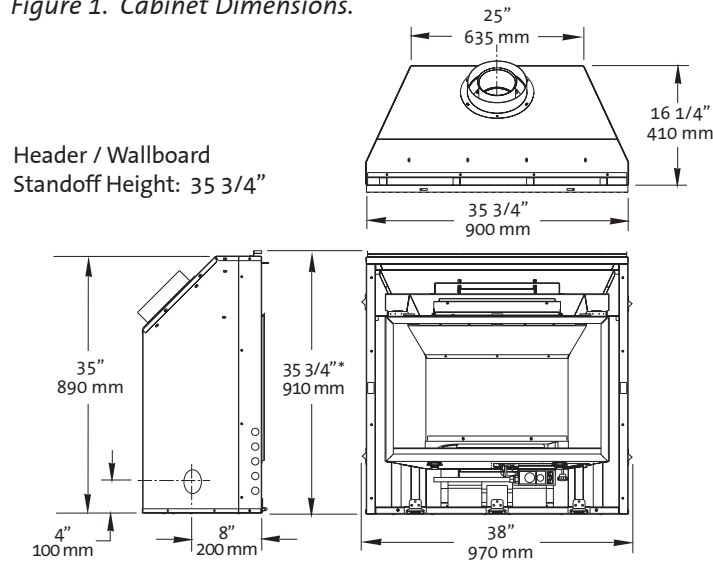

Header / Wallboard
Standoff Height: 35 3/4"

NOTE: DO NOT INSTALL CABINET ON FLOOR SURFACE LOWER THAN THE FRONTAL HEARTH SURFACE.

Figure 2. Minimum horizontal vent allowance through wall.

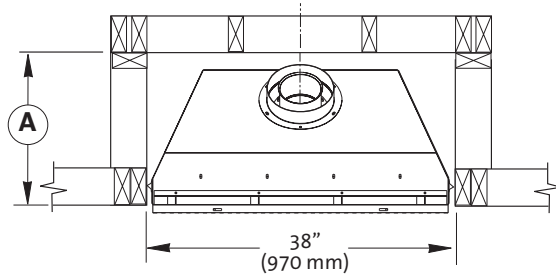
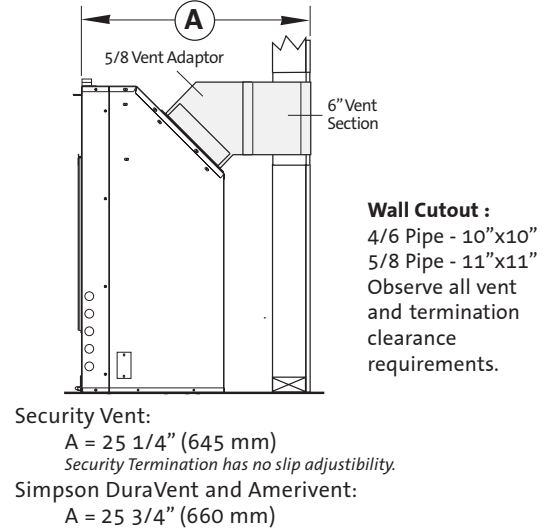

Horizontal Vent: Minimum depth accommodates the length of Vent Adaptor and one 6" vent section through wall construction.

Vent Adaptor: 5/8
A = 21 3/4"

Vertical Vent: Minimum depth includes 1 inch clearance between Vent Adaptor and combustible wall construction.

Vent Adaptor: 5/8 4/6
A = 21 1/2" 20"

Figure 3. Depth requirement to rear wall.

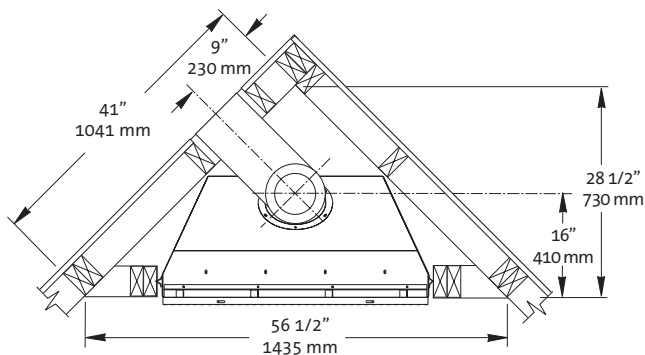

Figure 5. Corner framing dimensions.

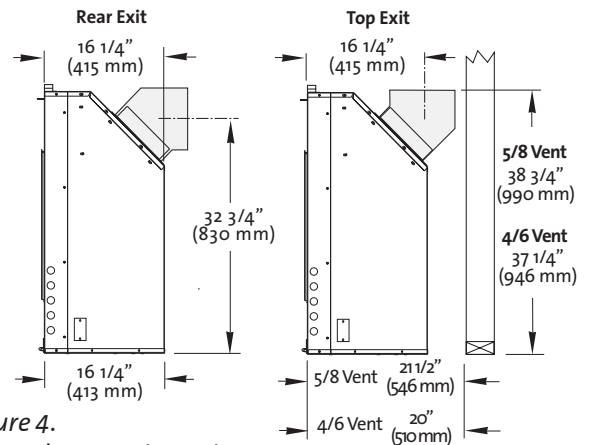

Figure 4. Vent Adaptor orientation.

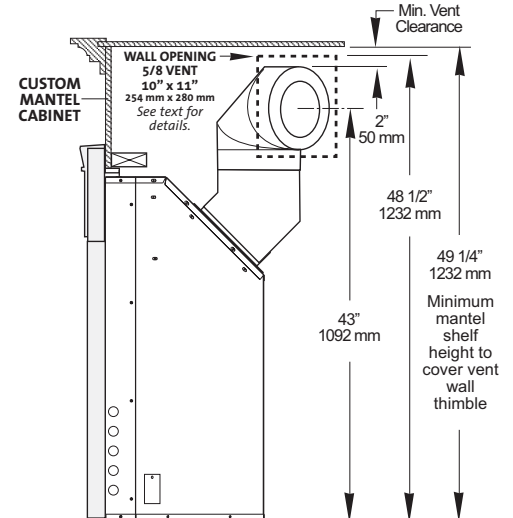

Figure 5a. Corner Installation - 5/8 vent, rear termination.

Hearth Protection

The GZ550 DV II Acadia is approved for installation without hearth protection. Combustible materials may be used on the floor directly under and in front of the fireplace. **NOTE: The floor surface under the unit must be level with, or higher than, the surface in front of the unit to allow the fireplace Controls Door to fully open.**

Facing and Clearance Requirements

The following clearance and hearth specifications are the minimum requirements for the GZ550 DV II Acadia gas fireplace. Measure clearances from the steel fireplace cabinet - not the cast iron surround panels. See Figures 6 - 8.

A combustible surface is anything that can burn (i.e. sheet rock, wallpaper, wood, fabrics etc.). These surfaces are not limited to those that are visible and also include materials that are behind non-combustibles.

If you are not sure of the combustible nature of a material, consult your local fire officials. "Fire Resistant" materials are considered combustible - they are difficult to ignite, but will burn. "Fire-rated" sheet rock is also considered combustible.

Maintain the proper clearances to the appliance to allow adequate flow of ventilation air around the fireplace.

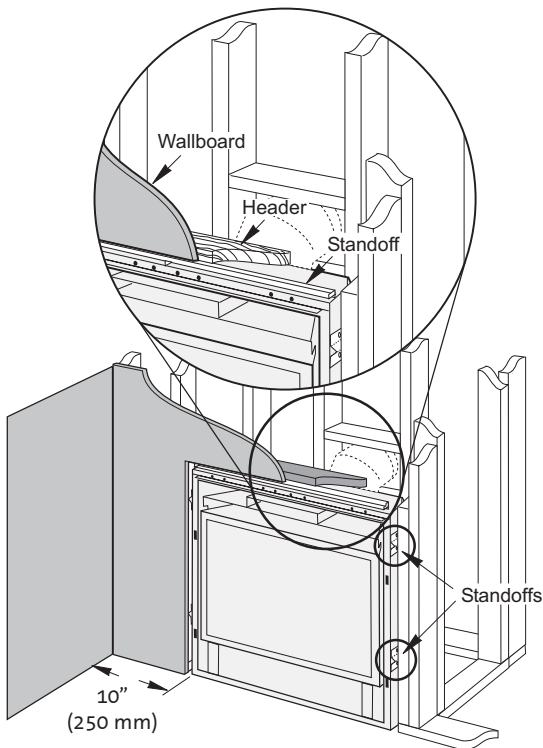

Figure 6. Header and Side Standoffs

Mantel and Trim Clearance

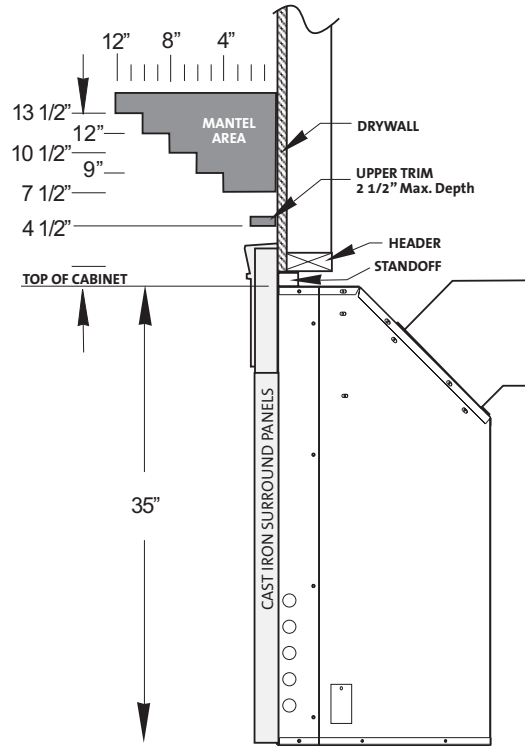

Figure 7. Minimum Mantel Clearances. Measure clearances from the top of the fireplace cabinet before installation of the cast iron surround panels.

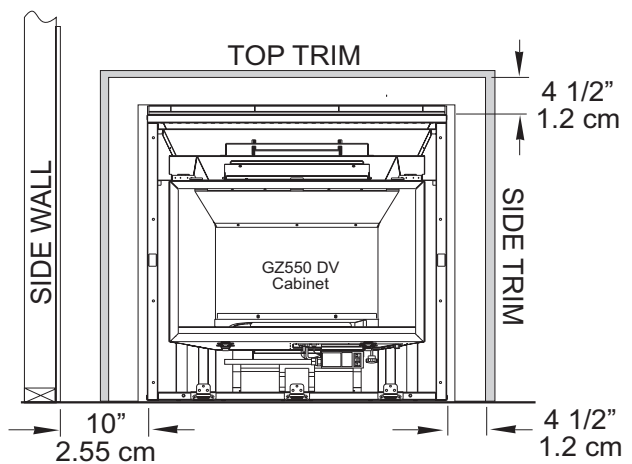

Figure 8. Minimum Wall and Trim Clearance. Measured from the cabinet, not standoffs or cast iron panels. Maximum Top & Side Trim depth: 2 1/2" (64 mm)

Vent Requirements

The GZ550 DV II Acadia Gas Fireplace is approved for use with direct vent components produced by the following manufacturers:

- Simpson Dura-Vent Corporation, 5/8 and 4/6 pipe
- Security Vent Ltd. International, 5/8 and 4/6 pipe
- Amerivent Corporation, 4/6 pipe
- Selkirk Metalbestos Corp. MDV Direct Vent Systems

Use vent components from a single vent manufacturer. Do not combine parts from different manufacturers in a single installation.

The vent termination must fall within the shaded area designated in the diagrams in Figures 12 - 14.

Venting Guidelines

- The minimum height for a vertical termination cap must be no less than **7'** from the top of the unit. The maximum height must not exceed **35'**.
- The minimum vent height above the roof or adjacent walls is specified by major building codes. Use the Gas Vent Rule as a general guide. See fig.10. requirements of the approval listing and the manufacturer's instructions.
- **Clearance (airspace) between Vent and Combustibles:**
Top - 2" (51 mm) Sides/Bottom - 1" (25 mm)
- **Wall Cutout Dimensions:**
4/6 Pipe - 10" x 10" 5/8 Pipe - 11" x 11"
- Any horizontal run must rise 1/4" per foot.
- Install venting in accordance with the vent manufacturers' instructions. Never modify any venting component, or use any damaged venting product.
- **THE GAS APPLIANCE AND VENT SYSTEM MUST BE VENTED DIRECTLY TO THE OUTSIDE OF THE BUILDING. DO NOT CONNECT VENT TO A CHIMNEY SERVING A SOLID FUEL OR ANOTHER GAS APPLIANCE.**

- **Joint Sealing Requirement:** Apply a 1/8" bead of high-temperature (750°F) sealant to the male section of the inner vent pipe. See fig. 9. The cement should seal the inner pipe from the outer pipe.

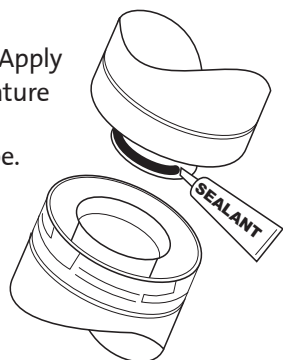

Figure 9. Seal each inner joint before joining pipe.

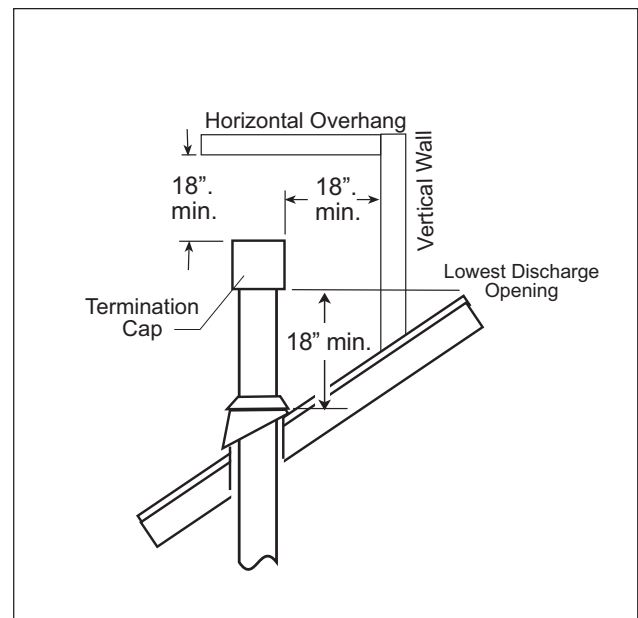

Figure 10. Gas Vent Height Rule: Vertical vent termination height above roof.

- Do not recess the vent terminal into a wall or siding.
- Inspect the vent system annually for blockage and deterioration. **If the vent-air intake system is disassembled for any reason, reinstall according to the instructions provided for initial installation.**
- Installation of any components not manufactured or approved by Jøtul or failure to meet all clearance requirements will void all warranties and may result in property damage, bodily injury, or loss of life.

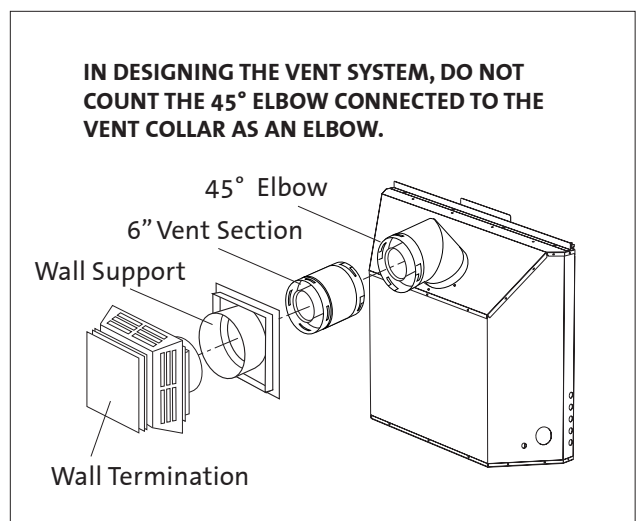

Figure 11. Typical minimum horizontal vent configuration - 5/8 Simpson DuraVent. Do not use 4/6 pipe in this configuration.

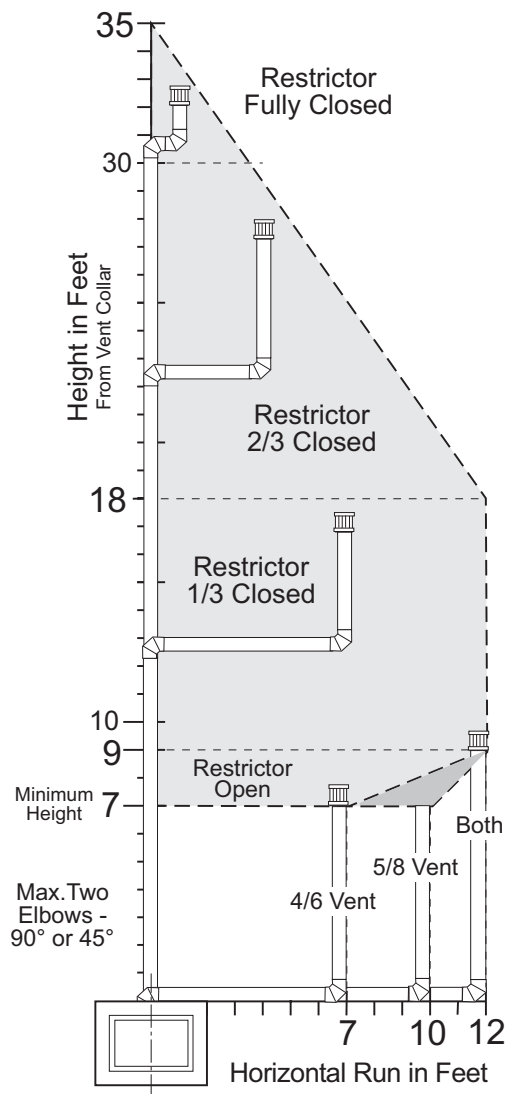

Figure 12. Vent Window for vertical termination using 5/8 or 4/6 pipe.

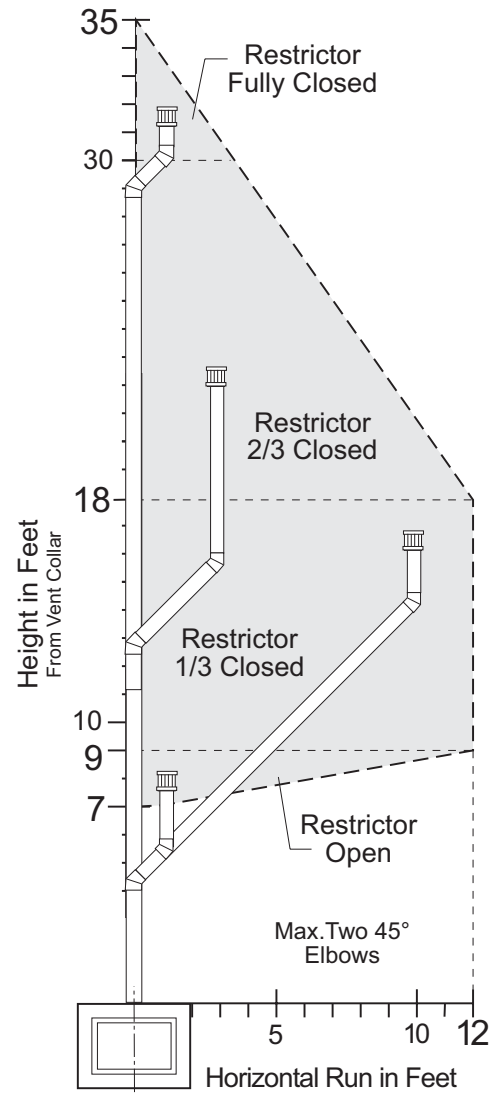

Figure 13. Vent Window for offset vertical termination using 5/8 or 4/6 pipe.

Vertical Termination

The vent must terminate within the shaded area designated on the graphs in Figs. 12 and 13.

- Maximum Elbows - Two 90° or Two 45° (**Do not count the first elbow off the vent collar.**)
- Use the restrictor settings indicated in the graph as general guide. The specific characteristics of your installation may require different settings.

Horizontal Termination

The vent must terminate within the shaded area designated in Figs. 15 and 16. (**Do not count the first elbow off the vent collar.**)

- Max. Elbows - One 90° or one 45°.
- Use of 4/6 pipe requires a minimum 1 foot rise. Fig. 16.

Figure 14. Minimum centerline for horizontal termination of 4/6 pipe

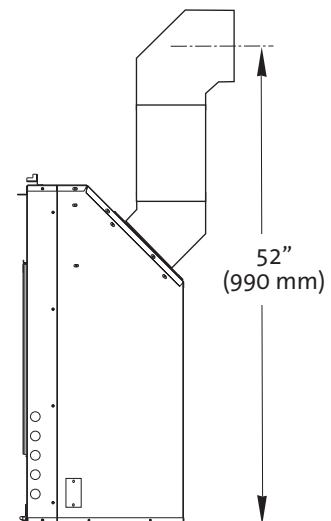

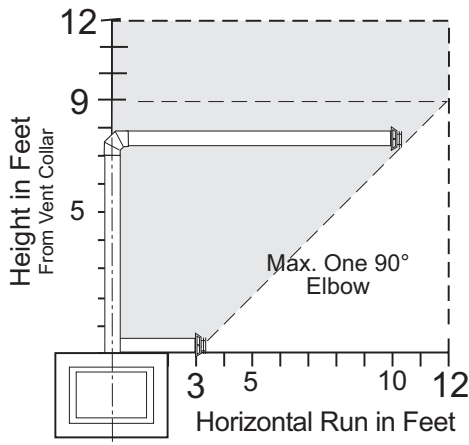

Figure 15. Horizontal termination -5/8 pipe.

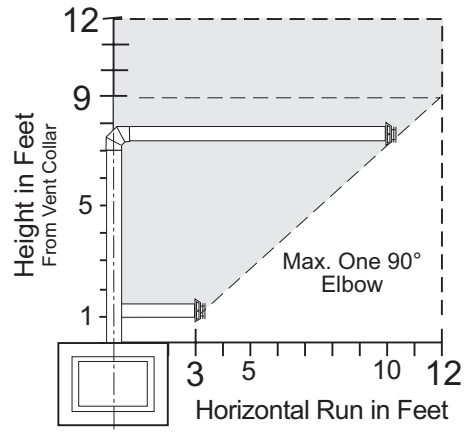

Figure 16. Horizontal Termination - 4/6 Pipe. Minimum 1 ft. rise required.

Horizontal Termination Clearance

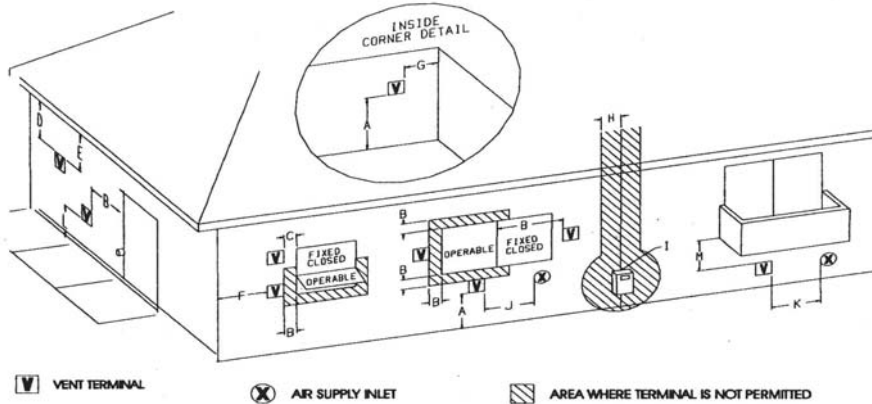

Figure 17. Vent Terminal Clearances.

- A** = Clearance above grade, veranda, porch, deck, or balcony: **12 inches (30 cm) minimum.**
- B** = Clearance to window or door that may be opened: ****Min. 9 inches, U.S. / *12 inches (30 cm) CAN.**
We recommend 12in. minimum to prevent condensation on the window.
- C** = Clearance to permanently closed window: ****Min. 9 inches, U.S. / *12 inches (30 cm) CAN**
We recommend 12 in. minimum to prevent condensation on the window.
- D** = Vertical clearance to ventilated soffit located above the terminal within a horizontal distance of 2 feet (60 cm) from the centerline of the terminal: **18 inches (46 cm) minimum.**
- E** = Clearance to unventilated soffit: **12 inches (30 cm) minimum.**
- F** = Clearance to outside corner: ****Min. 9 inches, U.S. / *12 inches (30 cm) CAN.** We strongly recommend 12 inches, particularly where windy conditions prevail.

* In accordance with **CSA B149 Installation Codes.**
**** In accordance with the current ANSI Z223.1/NFPA 54, National Fuel Gas Code. Note: Local Codes and Regulations may require different clearances.**

- G** = Clearance to inside corner: **** Min. 6 inches, U.S. / *12 inches (30 cm) CAN.** We strongly recommend 12 inches, particularly where windy conditions prevail.
- H** = *Not to be installed **within 15 feet (4.5 m) above a meter/regulator assembly within 3 feet (90 cm) horizontally** from the center-line of the regulator.
- I** = Clearance to service regulator vent outlet: **3 feet (91 cm) minimum.**
- J** = Clearance to nonmechanical air supply inlet to building or the combustion air inlet to any other appliance: **12 inches (30 cm) minimum.**
- K** = Clearance to a mechanical air supply inlet: ****Min. 3 feet (91 cm) above if within 10 feet horizontally, U.S. / *6 feet (1.83 m) minimum / CAN**
- L** = ¹ Clearance above paved sidewalk or a paved driveway located on public property: **7 feet (2.1 m) min.**
- M** = Clearance under veranda, porch, deck, or balcony: **12 inches (30 cm) minimum.²**

¹ A vent shall not terminate directly above a sidewalk or driveway which is located between two single family dwellings and serves both dwellings.

² Only permitted if veranda, porch, deck, or balcony, is fully open on a minimum of two sides beneath the floor.*

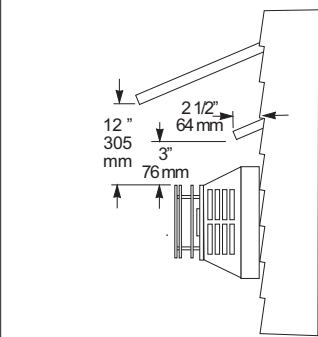

Figure 18. Wall Vent Terminal / Clearances to Overhangs

Fireplace Installation

Variable Vent Restriction

Vent restriction is accomplished by sliding a restrictor panel over the combustion air intake ports located at the back of the firebox. See Fig 19. The panel is set in a fully open position at the factory. Use the Vent Window diagrams in Figs. 12-13 as a starting point to determine the best restriction setting. Follow these steps to adjust the restriction as necessary:

1. Remove the Controls Panel to access the adjustment lever at the rear of the valve compartment. Simply loosen the two wingnuts that secure the panel to the cabinet floor and pull the panel forward. You do not need to disconnect any wires.
2. Locate the vent restriction wingnut protruding from the firebox floor at the rear of the valve compartment. Loosen the wingnut and push the lever to the left to increase restriction in one inch increments, e.g: 1 inch travel = 1/3 closed position.

The ideal restrictor setting for a particular vent system will vary depending on the specific installation characteristics. Once the fireplace is operating, further restrictor adjustment may be necessary to obtain the best performance. See the Operation chapter of this manual for more information.

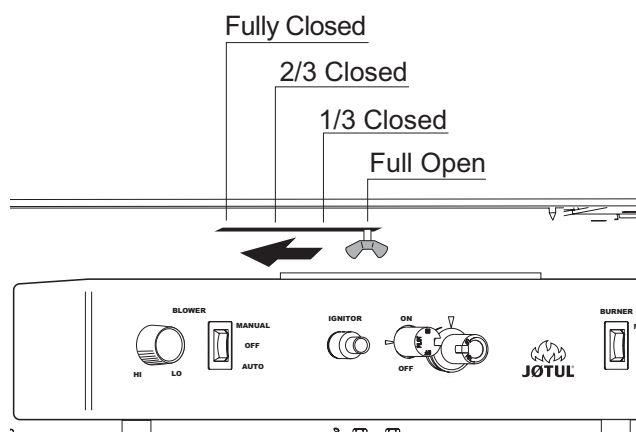

Figure 19. Vent restrictor adjustment.

Optional Blower

Install the optional Blower (155630) before installing the gas supply line.

Power Requirement

The blower must be electrically grounded in accordance with local codes or, in the absence of local codes, with the current NFPA 70- National Electrical Code or CSA C22.1-Canadian Code.

A three-prong (grounding) power supply plug is included for protection against shock hazard and should be plugged directly into a properly grounded three-prong receptacle. **DO NOT CUT OR REMOVE THE GROUNDING PRONG FROM THE PLUG.**

Blower Function

In the Auto mode, the blower is controlled by a heat activated switch (snapstat) that will turn the fan on and off as the firebox heats and cools. Use the Manual mode to over-ride the snapstat. If the blower is not needed, place the blower control switch in the OFF position and the snapstat will not function.

CAUTION: Always unplug the Blower when performing any routine service to the Acadia gas fireplace.

Installation

1. Loosen the two wingnuts that secure the Control Panel to the fireplace floor. Pull the panel forward and swing it to the right to access the rear of the cabinet. Do not disconnect any wires.
2. Insert a rubber grommet at each corner of the Base Plate as shown in fig. 20.
3. Engage the Blower unit base with the four studs at the rear of the fireplace cabinet floor. See fig. 21.
4. Insert the Snapstat into the slot in the Snapstat Bracket and, using the M6 nuts and 10 mm socket, attach the Control Switch / Snapstat Bracket to the two studs protruding from the firebox floor. See fig. 22.
5. Connect the Blower Wire harness to the switch connector at the back of the Control Panel. Connect the two other leads to either terminal on the snapstat. Attach the green ground wire to the left Control Panel mounting stud. Replace the Control Panel and tighten the wingnuts.
6. Run the power cord to the duplex receptacle in the side of the cabinet. Gather slack cord into the side cavity, away from the plumbing and other wiring.

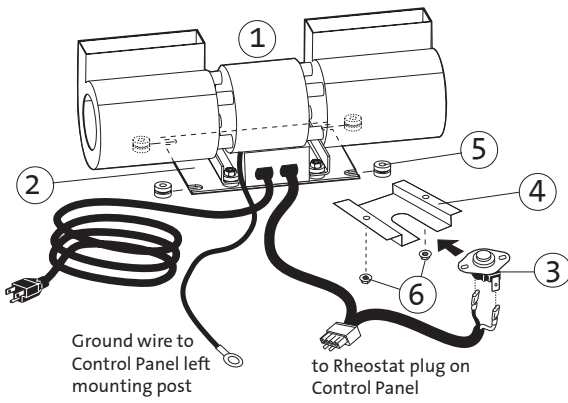

1. #129374 Fan/Motor Unit
2. #220012 Base Plate
3. #220637 Snapstat (140°F - 120°F)
4. #220989 Snapstat Bracket
5. #220055 Grommets, 4
6. #9930 M6 Hex Nuts, 2

Figure 20. Blower Kit 155630 contents.

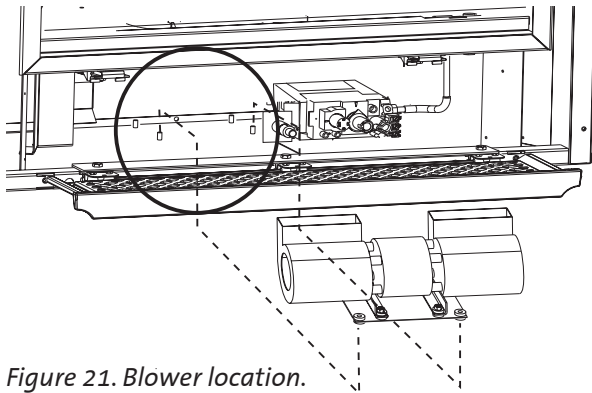

Figure 21. Blower location.

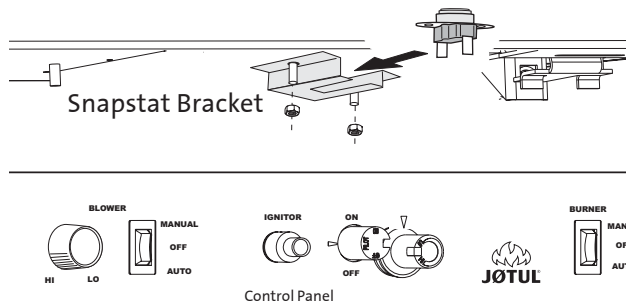

Figure 22. Install snapstat bracket and switch box.

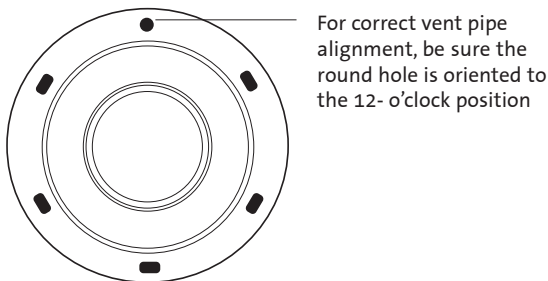

Figure 23. 4/6 Vent Collar orientation.

Final Cabinet Positioning

1. **If appropriate, attach the 4/6 Vent Adaptor Collar:**
 - Remove the 5/8 Collar supplied with the unit.
 - Align the 4/6 Collar as shown in fig. 23 and secure to the unit using the original screws. **Be sure the single round fastener hole is oriented to the 12 o'clock position for proper vent alignment.**
1. **Side Standoffs:** Remove the retainer screws. Using vise grips or pliers, fold each standoff at the perforations. Secure each standoff using the screws previously removed. See fig. 24.
2. **Wall Stud Brace:** Loosen, bend, and position each cabinet Retainer Strap for attachment to the fireplace enclosure. See fig. 24.
3. Locate the fireplace cabinet in its final position within the enclosure. Confirm that the first 45° Elbow is correctly aligned for final vent assembly and secure it to the Vent Collar using 3, #10 sheet metal screws.
4. Confirm that the cabinet is positioned to align its forward edge with the finished surface of the wall facing. The stud braces allow approximately 2 inches of forward adjustment to accommodate most any facing thickness. Secure the braces to the enclosure frame.
5. Complete the gas line and electrical power routing as appropriate for blower and thermostat functions.

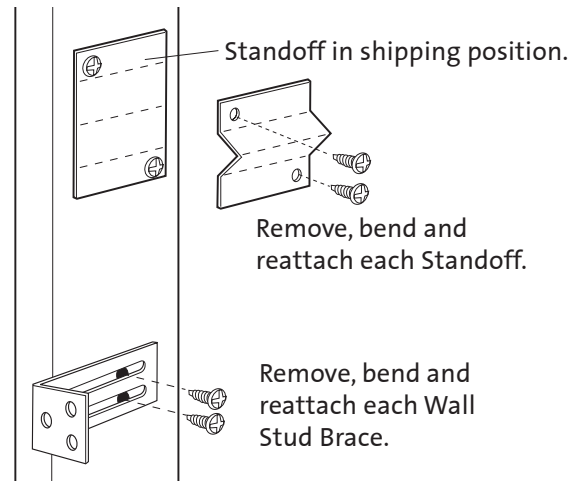

Figure 24. Standoff and Stud Brace orientation.

Connect the Gas Supply

Gas Supply Requirements

ALL INSTALLATIONS MUST COMPLY WITH LOCAL CODE OR IN THE ABSENCE OF LOCAL CODE, MUST COMPLY WITH THE MOST RECENT EDITION OF THE NATIONAL FUEL GAS CODE ANSI Z223.1/NFPA 54 OR CAN-B149.

Shutoff Valve

All codes require a gas shutoff valve (gas cock) and union to be installed in the supply line and in the same room as the appliance. This allows for the disconnection of the fireplace for servicing and maintenance. See fig. 25.

A T-handle gas shutoff valve is required in Massachusetts in compliance with Code 248CMR.

The fireplace and gas control valve must be disconnected from the gas supply piping during any pressure testing of the system at test pressures in excess of 1/2 psig. For pressures lower than 1/2 psig, isolate the gas supply by closing the manual shutoff valve.

Control Valve Connection

The gas supply line connection is made to the left side of the valve. The gas supply line should be a minimum 3/8" diameter, or the appropriate size to provide sufficient gas pressure to the valve regardless of the input setting.

The use of flexible gas appliance connectors is acceptable in many areas in the U.S. In Canada, methods vary depending on local code. If local codes permit, use flexible gas line for ease of installation and service. For those locales where flexible gas lines are not permitted, use the 3/8" iron fitting to make the connection at the left side of the Control Valve. See Figures 25 and 26.

Secure all joints tightly using appropriate tools and sealing compounds (for propane units, be sure to use compounds that are propane resistant). Turn on gas supply and test for gas leaks using a soapy water solution. Never use an open flame to check for leaks.

Leak test:

- Mix a 50-50 solution of water and dish soap.
- Light appliance- see lighting instructions on page 23 of this manual or on the fireplace's rating plate.
- Brush or spray all joints and connections with the soapy water solution.
- If bubbles appear at any connection or seam or a gas odor is detected, immediately turn gas control knob to the OFF position.

Tighten or reconnect the leaking joint and retest for any gas leaks.

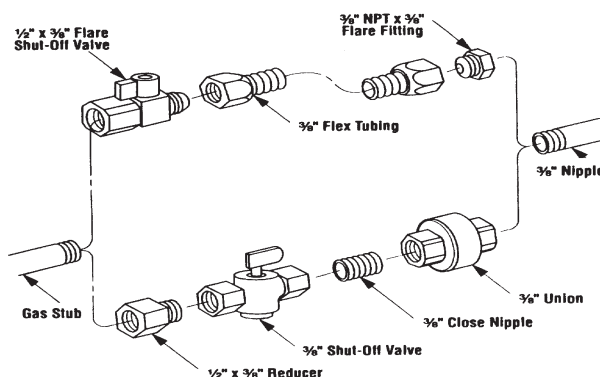

Figure 25. Gas supply line fittings.

Gas Pressure

Proper gas pressure provides a consistent flow of gas to the appliance and is instrumental in checking for gas leaks. The gas control valve on the fireplace is equipped with pressure test points for gauge connections. The gauge connections are located on the front of the valve under the On/Off/Pilot knob. Gauge connections are identified by:

- **IN/E** for **inlet** or supply pressure (the amount of gas coming to the valve.)
- **OUT/A** for **manifold** pressure (the amount of gas that is coming out of the valve to the burner.)

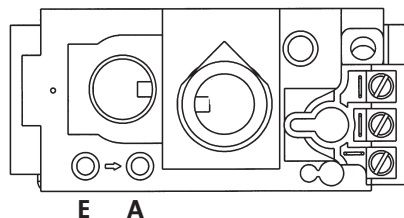

Figure 26. Pressure test point as located on the front of the valve.

The appliance must be isolated from the gas supply line by closing its individual manual gas shutoff valve (gas cock) during any pressure testing of the gas supply piping system that is equal to or less than pressures of 1/2 psig (3.5 kPa).

Inlet Pressure

	<u>MIN</u>	<u>MAX</u>
Natural Gas:	5.0 WC (1.24 kPa)	11.0 WC (2.74 kPa)
Propane:	12.0 WC (2.98 kPa)	14.9 WC (3.71kPa)

Manifold Pressure

	<u>MIN</u>	<u>MAX</u>
Natural Gas:	1.2 WC (.29 kPa)	3.8 WC (.94 kPa)
Propane:	2.9 WC (.72 kPa)	11.0 WC (2.74 kPa)

ALWAYS TEST PRESSURE WITH VALVE CONTROL KNOB SET ON HIGH. Symptoms of incorrect gas pressure include:

Insufficient gas pressure:

- Small pilot flame which can result in insufficient millivolts.
- Little variation in flame picture between HI and LO settings.
- Insufficient gas to support more than one appliance causing nuisance outages or gas surges.

Excessive gas pressure:

- Permanent damage to valve causing complete appliance shut down.
- Too large a pilot flame resulting in overheating of the power generator and consequent shut down.
- Sooting due to impingement and/or incorrect fuel to air mix.

High Altitude Adjustment

Installations located at altitudes from 2000 - 4500 ft. (610 M - 1370 M), require compensation for the thinner air (less volume of air per cubic foot). Higher altitudes affect the atmospheric pressure and heat value of gaseous fuels. The lower oxygen content in the air and the lower gas viscosity require the use of a different orifice to achieve efficient, clean combustion at the burner tube.

For high altitude installations consult the local gas distributor or the authority having jurisdiction for proper rating methods. If the installer must convert the unit to adjust for varying altitudes, use Jøtul High Altitude Kit (#155610-NG / #155611-LP).

In the U.S: THE DERATING KIT MUST BE INSTALLED BY AN AUTHORIZED SERVICE TECHNICIAN IN ACCOR-

DANCE WITH THE MANUFACTURER'S INSTRUCTIONS AND ALL CODES AND REQUIREMENTS OF THE AUTHORITY HAVING JURISDICTION. THE INFORMATION STICKER MUST BE COMPLETED BY THE INSTALLER AND APPLIED TO THE APPLIANCE AT THE TIME OF THE CONVERSION. THE QUALIFIED SERVICE AGENCY PERFORMING THIS WORK ASSUMES RESPONSIBILITY FOR THIS DERATING.

In Canada: This unit has been tested for installation at high altitudes in accordance with Canadian test standard CAN/CGA-2.17. THE DERATING SHALL BE CARRIED OUT IN ACCORDANCE WITH THE REQUIREMENTS OF THE PROVINCIAL AUTHORITIES HAVING JURISDICTION AND IN ACCORDANCE WITH THE REQUIREMENTS OF THE CAN1-B-149.1 AND .2 INSTALLATION CODE.

Derating Procedure

1. Follow Steps 1-4 of the Fuel Conversion procedure outlined on page 14.
2. Remove the original orifice. Consult Table 1 to determine the correct orifice size for your elevation and fuel type. Install the appropriate orifice included in the high altitude kit.
3. Fill out the high altitude conversion label and attach to the rating plate or fireplace cabinet floor See Figure 27.
4. Reassemble the firebox components.
5. It may be necessary to adjust the air shutter on the burner tube. See the AIR SHUTTER/FLAME APPEARANCE section of this manual for more details.

High Altitude Orifice Chart			
Elevation	Fuel	Orifice Size	Part No.
0 - 2000 ft. (0 - 610 m)	Natural Gas Propane	#38 1.55 mm	129130 220048
2001 - 4500 ft. (611 - 1370 m)	Natural Gas Propane	#39 1.50 mm	129367 129146

Table 1. High Altitude Orifice Chart.

THIS STOVE HAS BEEN CONVERTED FOR USE AT AN ALTITUDE OF: _____			
Orifice Size:	_____	Manifold Press.	_____
Input Btu/Hr.	_____	Fuel Type	_____
Date of Conversion	_____		

Figure 27. High Altitude Conversion Label.

Fuel Conversion

The GZ550 DV Acadia Fireplace is designed to for use with either Natural gas or Propane. It is shipped from the factory configured to use Natural gas. A conversion kit is included for conversion to Propane use if desired. Check the identification label on the Control Valve to confirm that the correct fuel is used.

WARNING:

THE CONVERSION KIT IS TO BE INSTALLED BY AN AUTHORIZED JØTUL SERVICE TECHNICIAN IN ACCORDANCE WITH THE MANUFACTURER'S INSTRUCTION AND ALL CODES AND REQUIREMENTS OF THE AUTHORITY HAVING JURISDICTION. FAILURE TO FOLLOW THESE INSTRUCTIONS COULD RESULT IN SERIOUS INJURY OR PROPERTY DAMAGE. THE QUALIFIED AGENCY PERFORMING THIS WORK ASSUMES RESPONSIBILITY FOR THIS CONVERSION.

IN CANADA:

THE CONVERSION SHALL BE CARRIED OUT IN ACCORDANCE WITH THE REQUIREMENTS OF THE PROVINCIAL AUTHORITIES HAVING JURISDICTION AND IN ACCORDANCE WITH THE REQUIREMENTS OF THE CAN1-B149.1 AND .2 INSTALLATION CODE.

Cet équipement de conversion sera installé par une agence qualifiée de service conformément aux instructions du fabricant et toutes exigences et codes applicables de l'autorités avoir la juridiction. Si l'information dans cette Instruction n'est pas suivie exactement, un feu, explosion ou production de protoxyde de carbone peut resulter blessure personnelle de vie. L'agence qualifiée de service est responsable de l'installation n'est pas propre et complete jusqu'a l'operation de l'appareil converti est cheque suivant les criteres etablis dans les instructions de propriétaire provisionnees avec l'équipement.

Tools required:

1/4" Nut driver, 7/16" and 1/2" open end wrench or deep well socket, 4 mm allen wrench, Torx t20 or slotted screwdriver.

Conversion Kit Contents:

- 1 Regulator Tower labeled for Propane
- 3 Regulator Tower Screws
- 1 Burner Orifice (#38 NG, 1.55 mm LP)
- 1 Pilot Orifice (#30 for LP, #51 for NG)
- Label A - to be completed and applied to the back of the fireplace.
- Label B - apply to the fireplace Rating Plate as designated on the plate.

WARNING: If appropriate, be sure to unplug the blower before proceeding with this conversion.

Fuel Conversion Procedure

1. Remove the Glass Frame:

- Follow the removal procedure detailed on page 1.

2. Empty the firebox:

- Lift and remove the Fettle and Logset package. CAUTION: THE LOGS ARE FRAGILE. Handle them with care and set aside out of the way.
- **Remove the Burner Skirt.** Lift and tilt it to clear the firebox opening. See fig. 28.

3. Change the Burner Orifice:

- Loosen the locknut on the Air Shutter Stem, located under the firebox floor to the right of the Control Valve. Pull the stem forward as far as it will go. This will allow you to disengage the Burner Assembly. See fig. 29.
- Lift the rear of the Burner Tube and rotate slightly forward. Slide the tube back enough to disengage it from the Air Shutter and Burner Orifice, then lift out. See fig. 30.
- Slide the Air Shutter back out of the way to expose the orifice. See fig. 31. Using a 1/2" open end wrench or deep well socket remove the burner orifice and replace with the appropriate orifice, supplied in the kit.

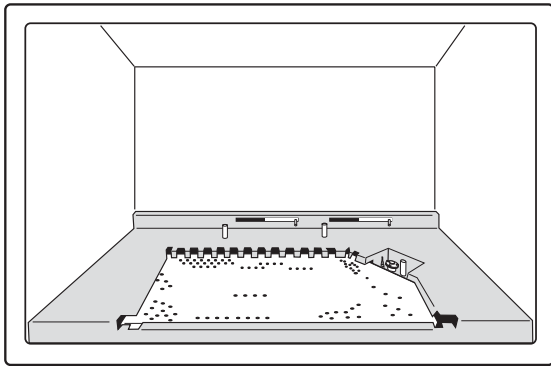

Figure 28. Lift the Burner Skirt up and out of the firebox.

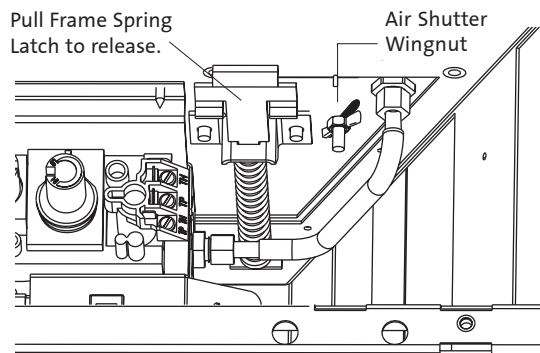

Figure 29. Frame latch and air shutter stem location.

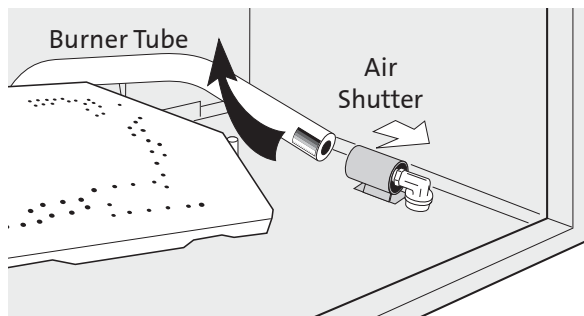

Figure 30. Move shutter forward to disengage the burner tube assembly.

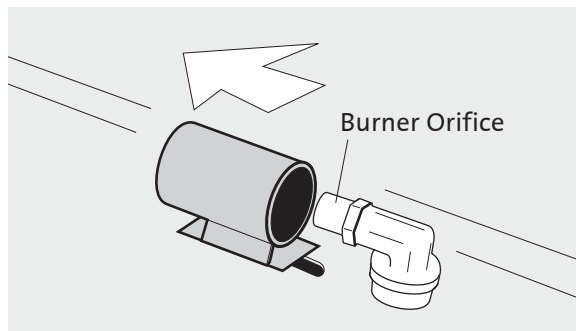

Figure 31. Move air shutter back to access the burner orifice.

4. Change the Pilot Orifice:

- FROM WITHIN THE FIREBOX, disengage the Pilot Hood by releasing the retainer clip as shown in fig. 32. Using the 4 mm hex key supplied, unscrew the pilot orifice (counterclockwise). Replace with the appropriate orifice: #51 for Natural gas #30 for Propane

Tighten new orifice into the base of the pilot assembly.

- Replace Pilot Hood by pushing it into the base.

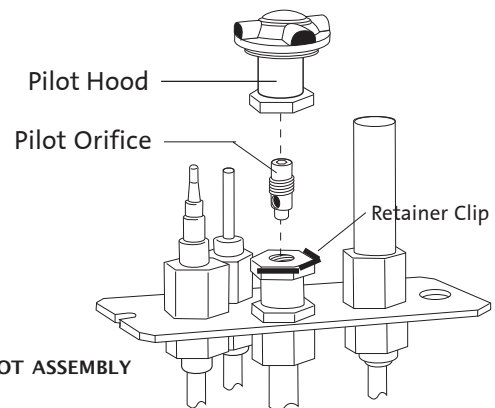

Figure 32. Pilot Orifice replacement.

5. Replace the Burner Tube: Slip the end of the tube into the Air Shutter and SLIDE TUBE FORWARD TO COMPLETELY COVER THE BURNER ORIFICE.

6. Adjust the Air Shutter: See fig. 33.

- Slide the shutter BACK to open the inlet, slide FORWARD to close. The standard settings are:
Natural gas - 1/4" open
Propane - 1/2" open
- Tighten the wing nut on the Air Shutter Stem.
- Replace the Burner Skirt.

7. Change the Regulator: See fig. 34.

- Using a Torx T-20 screwdriver or small flat head screwdriver, remove the three specialty screws from the front of the valve regulator.
- Remove the regulator tower and gasket.
BE SURE TO REMOVE THE BLACK RUBBER GASKET FROM THE VALVE.
- Install the new variable regulator tower with the new rubber gasket. **Thoroughly** tighten new regulator to valve body.

8. Apply the Conversion Labels:

- Apply LABEL A to the cabinet floor so that it may be seen by anyone servicing the fireplace.
- Apply LABEL B to the Rating Plate in the space provided.

9. Reassemble the fireplace, apply gas to the system and check for gas leaks including all gas lines before and after the valve. NEVER USE AN OPEN FLAME TO CHECK FOR GAS LEAKS.

IMPORTANT: Correct gas pressure is essential for efficient and safe operation. It is important that the correct gas pressure be established at the time of the installation. For more details, see the Gas Pressure section of this manual on page 12.

WHEN LIGHTING THIS APPLIANCE, ALWAYS REFER TO THE LIGHTING INSTRUCTIONS ON THE BACK COVER OF THIS MANUAL.

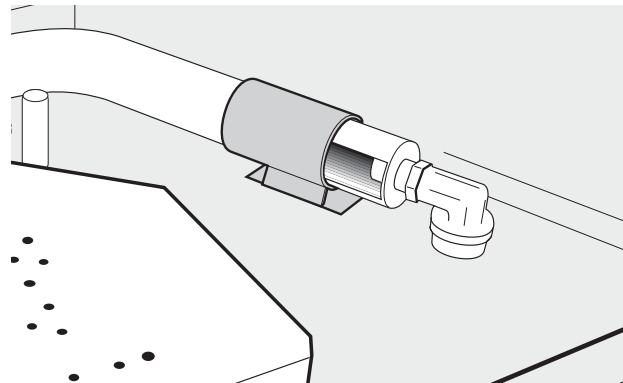
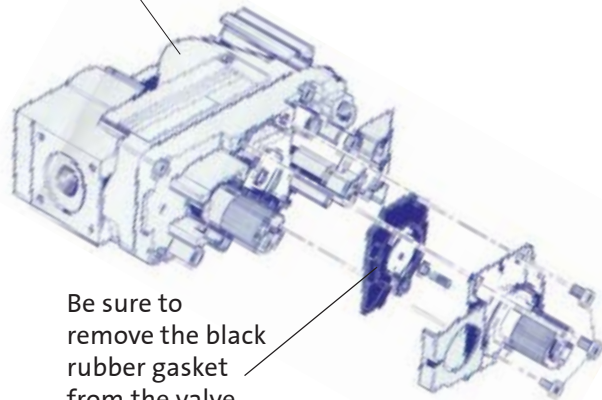

Figure 33. Adjust Air Shutter as appropriate. Fully open position is shown here. Slide shutter forward to close.

Apply small conversion notice label here.



Be sure to remove the black rubber gasket from the valve.

Figure 34. Valve Regulator replacement.

Wall Thermostat Installation

Use Jøtul Thermostat #129706 or a **750 millivolt DC two-wire circuit thermostat** to automatically control your fireplace operation. The thermostat should be placed in the same room as the heater, typically 5' off the floor. Avoid drafty areas or any area that may affect the accuracy of the thermostat.

The thermostat should be connected to the Acadia using a minimum of 16 gauge wire with a maximum length of 35 feet of wire.

Connect the two thermostat wire leads to the two lower terminals on the terminal block located to the right of the ON/OFF/T'STAT switch. Do not overtighten the connections. IT IS NOT NECESSARY TO DISCONNECT ANY OTHER WIRES. See Figure 34.

At the thermostat, the two wires should be connected to the two connections screw on the thermostat base plate per the manufacturer's instructions.

For thermostatic function, place the ON/OFF/T-STAT switch in the T-STAT position and the pilot flame must be lit.

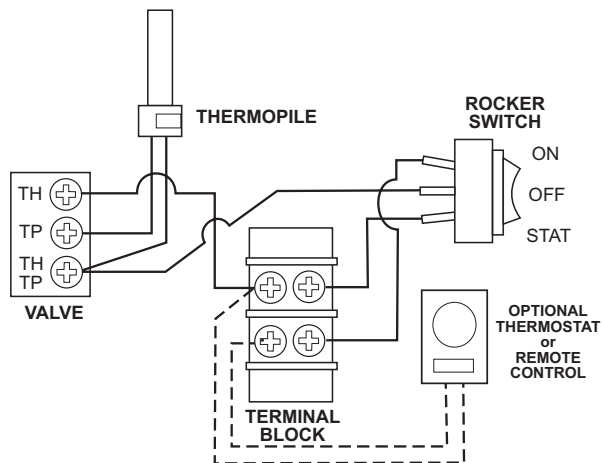

Figure 36. GZ 550 DV II Acadia Wiring Diagram.

Remote Control

The optional Jøtul Remote Control can be installed on the Acadia gas fireplace. Using the wire supplied with the remote, connect the remote directly to the gas control valve. See fig. 36

Connect one receiver lead to the terminal labelled TH. Connect the other receiver lead to the terminal labeled TH/TP. DO NOT DISCONNECT ANY OTHER WIRES FROM THE VALVE, AND DO NOT OVERTIGHTEN THE TERMINAL SCREWS.

Place the receiver unit under the control valve on the floor of the fireplace cabinet.

CAUTION:

LABEL ALL WIRES PRIOR TO DISCONNECTION WHEN SERVICING THE CONTROLS. WIRING ERRORS CAN CAUSE IMPROPER AND DANGEROUS OPERATION. ALWAYS VERIFY PROPER OPERATION AFTER SERVICING THE APPLIANCE.

ATTENTION:

AU MOMENT DE L'ENTRETIENDES COMMANDES, ETIQUETEZ TOUS LES FILS AVANT LE DEBRANCHEMENT. DES ERREURS DE CABLAGE PEUVENT ENTRAINDRE UN FONCTIONNEMENT INADEQUAT ET DAGEREUX.

Brick Panel Assembly

Install the optional 155805 Brick Panels before placing the Logset. Place the panels in position in the order as numbered in fig. 37. No fasteners or tools are required.

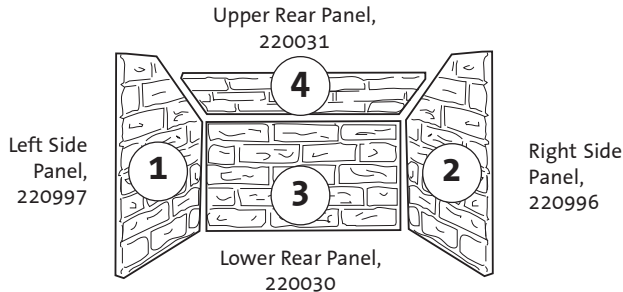

Figure 37. Panel installation order.

1. **Remove the Glass Frame, if you have not already done so.** Open the lower control panel and locate the two frame latches under the firebox floor. See fig. 38. Pull the latch handle forward to disengage it from the bottom of the glass frame. You can then pull the frame out and up off of the three retainer tabs at the top of the firebox opening. Set the Glass Frame out of the way.
2. **Remove the Fettle and Logset.** These parts are not fastened. Simply lift them out of the firebox.
3. **Install the Side Panels.** Set the bottom edge of each side panel on the Burner Skirt and against the firebox wall. Push the panel forward against the front lip of the firebox opening. See fig. 39.
4. **Install the Lower Rear Panel.** Orient the panel so that the beveled edge is on top and the mortar joints align with those on the side panels. Set the bottom edge on the shelf above the restrictor adjustment slots at the back of the firebox. The panel should fit snugly between the two side panels. See fig. 40.
5. **Install the Upper Rear Panel.** This will also be a snug fit. Set the panel up high and then carefully lower it to seat its lower edge against the top of the other rear panel. The side panels will hold it in place.

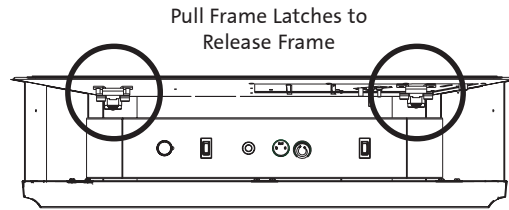

Figure 38. Glass Frame latch locations.

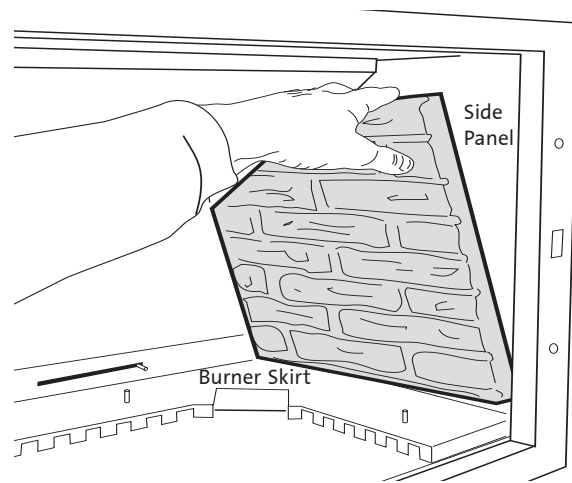

Figure 39. Install the Side Panels.

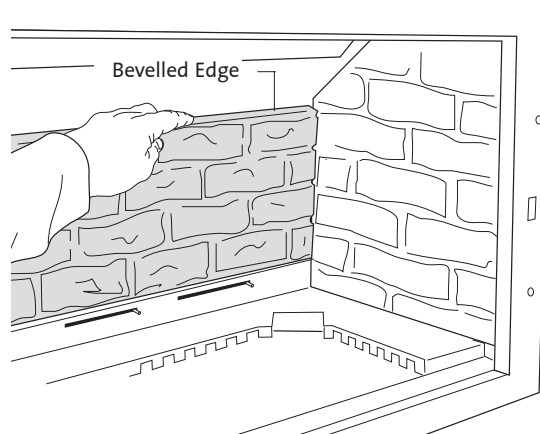

Figure 40. Install Lower Rear Panel.

Logset Assembly

Unpack and arrange the five logs as outlined below.
CAUTION: The logs are fragile. Handle with care.

1. Seat Right Log (1) on the pin on the right side of the Burner Skirt. fig. 41.
2. Set Rear Log (2) on the pins at the rear of the Burner Skirt. This log should overlap the back of the Right Log.
3. Set the Left Log (3) on the pins at the left side of the Burner Skirt.
4. Set the end of Front Log (4) into the pocket at the rear of Left Log (3). Engage the other end with the pin in the middle of the Burner Plate. Fig. 42.
5. Engage the upper end of the Cross-over Log (5) with the pin in the Rear Log. Fig. 42. Set the Cross-over Log across the top of the lower end of the Front Log (4) as illustrated.
6. Spread a layer of ember stones evenly over the surface of the Burner Plate. Allow for 1/4" clearance between the stones and the inner edge of the Burner Skirt. **Avoid blocking the pilot flame area with ember stones. See Fig. 43.**
7. **Replace the Glass Panel Frame:** Engage the top of the frame with the three tabs at the top of the firebox. Push the bottom of the frame against the firebox face and pull the Frame Latches out to engage them with the slots in the bottom of the frame.

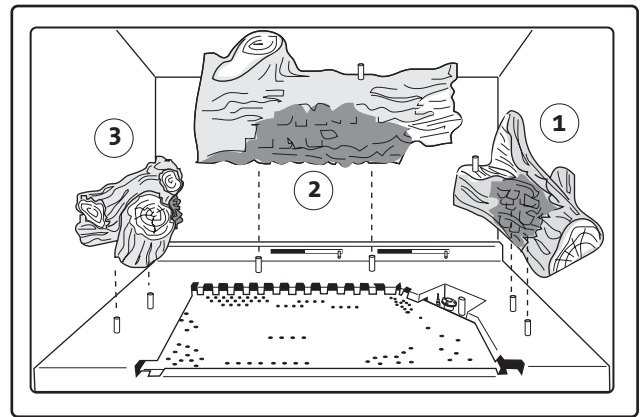

Figure 41. Install Right Log, Rear Log and Left Log in that order.

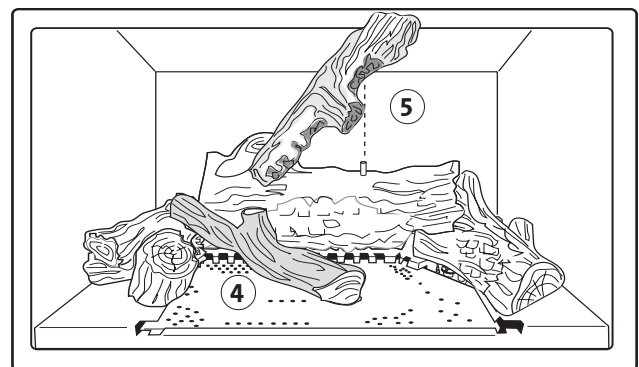

Figure 42. Install Front and Cross-over logs as shown.

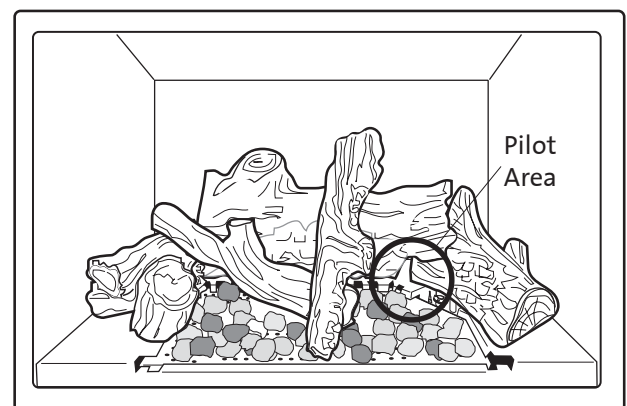

Figure 43. Install ember stones, keeping clearance around the pilot crossover area.

Surround Assembly

1. Cut and remove the plastic wire tie from the Lower Grille / Control Door and open the door.
2. Install each of the Side castings onto the cabinet by engaging the hanger tabs with the holes in the cabinet frame. See fig. 52 for orientation. You may wish to secure each side panel to the bottom of the fireplace cabinet using the M6 flat head screw already installed at those locations. It will be necessary to remove the Control Door first.
3. Install the Right and Left Upper Grill plates.
4. Attach the Inner Panel to the Center Plate. The Inner Panel may be reversed to show the winter scene. (Note: Blue Black Panel is enamelled on one side only).
5. Hang the Center Plate in position.

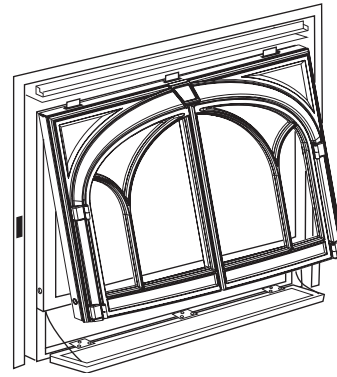

Figure 45. Hang the frame on the cabinet.

Optional Double Door

The Double Door set is fully assembled and requires no tools for installation. Use the 4 mm hex key supplied with the doors to adjust the door alignment at the eight socket head hinge screws.

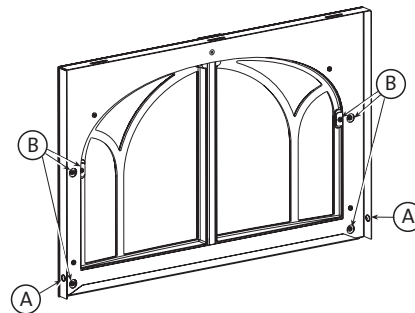

Figure 46. Rear view of door frame.

Door Installation

Unpack the door set and inspect the parts for damage. Notify your dealer if any damage is found.

You may wish to remove the doors from the frame to lighten the assembly and ease installation. They simply lift off of the hinges.

The door assembly attaches to the fireplace by engaging the three slots in the upper frame with the corresponding steel tabs at the top of the firebox. See fig. 45.

A dimple located on the inside of the frame at each lower corner engages with corresponding holes in the glass frame to hold the bottom of the door assembly securely to the firebox. See A, fig. 46.

1. Open the Control Access Door. Hang the door frame onto the firebox by engaging the tabs with the holes in the frames. See fig. 45.
2. Push the frame over to one side and engage the dimple on that lower corner with the hole in the side of the glass frame. You will feel it lock into place.
3. Push the frame assembly over to the opposite side and push that lower corner down to engage with the firebox.

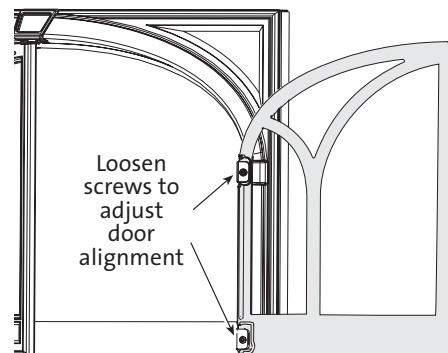

Figure 47. Door adjustment points.

Door Alignment Adjustment

You can adjust the door alignment if necessary by loosening the hinge screws (See B, fig. 46 and fig. 47). Realign the door and then tighten the screws.

System Check

- 1. PURGING THE GAS LINE:** When lighting the appliance for the first time it will take a few moments to clear the gas line of air. Once this purge is complete, the appliance will operate as described in the lighting instructions located on the fireplace's rating plate and back cover of this manual.
- 2. PILOT FLAME:** The pilot flame should be steady, not lifting or floating. The flame should be blue in color around the pilot hood, with traces of yellow toward the outer edges. It is imperative that the pilot flame engulf the top 3/8" of the thermopile (power generator) and the top 1/8" of the quick drop out thermocouple. The pilot flame should project out of the pilot hood 1" at all three ports. See Figure 48.
- 3. BURNER ADJUSTMENT:** Your Jøtul GZ550 Acadia gas fireplace is equipped with a variable gas control valve. This valve provides easy adjustment of the flame height appearance and heat output. To adjust the flame between the HI and LO setting, rotate the HI/LO knob, located in the center of the valve face. Flame height will adjust approximately 1.0" to 1.5" between the HI and LO settings.

NO SMOKE OR SOOT SHOULD BE PRESENT. CHECK LOG PLACEMENT IF ANY SOOT OR SMOKE IS DETECTED. IF SOOT OR SMOKE PERSISTS, THE AIR SHUTTER MAY NEED TO BE ADJUSTED.

CAUTION:

DO NOT ATTEMPT TO ALTER THE FLAME APPEARANCE BY POSITIONING THE GAS VALVE IN ANY OTHER POSITION OTHER THAN THE FULL "ON" POSITION.

Flame Appearance / Air Shutter Adjustment

THE ACADIA GAS FIREPLACE IS SHIPPED FROM THE FACTORY EQUIPPED TO USE NATURAL GAS. IF THE BURNER HAS BEEN CONVERTED FOR USE WITH PROPANE, IT WILL BE NECESSARY TO ADJUST THE AIR SHUTTER ON THE BURNER TUBE TO ACHIEVE THE PROPER GAS TO AIR MIX. See Figure 26.

WARNING:
AIR SHUTTER ADJUSTMENTS SHOULD ONLY BE PERFORMED BY A QUALIFIED PROFESSIONAL SERVICE TECHNICIAN.

The air shutter adjustment can also help achieve the desired flame appearance. Generally, flame appearance is a matter of individual preference, however a warm yellowish flame is most common. See fig. 49.

Closing the air shutter - will generate very long yellow flames resulting in soot. Sooting produces black deposits on the logs, on the inside walls of the appliance, and potentially on the exterior termination cap.

Sooting is caused by incomplete combustion in the flames and lack of combustion air entering the air shutter opening.

Opening the air shutter - will generate a flame that is blue and transparent, or an "anemic" flame. This flame is generally more efficient but not as pretty.

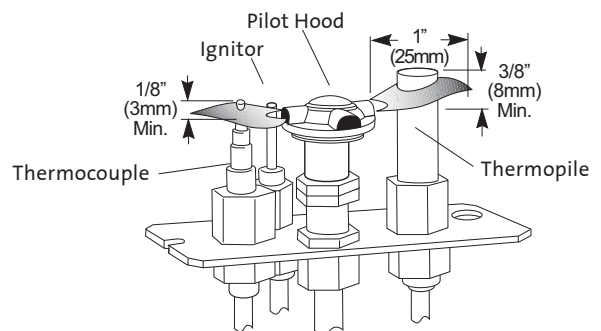

Figure 48 Correct Pilot Flame Pattern

Air Shutter Adjustment

1. Open the Lower Grill panel and locate the Air Shutter adjustment stem extending down from the right side of the firebox floor. See figs. 49.
2. Loosen the locknut and push the stem BACK (to the rear of the firebox) to open the air inlet increasing airflow into the burner. Push the stem FORWARD to decrease the air inlet. Make adjustments in 1/8" (3 mm) increments and allow time for flame pattern to respond to the new setting. Retighten the locknut when the desired flame pattern is established.
3. Reassemble the fireplace including glass assembly. Allow the fireplace to burn 15 -20 minutes on the HIGH setting, observing the flame continuously.
4. If the flame appears weak, slow, or sooty, repeat the process described above until the flame is as desired.

Air Inlet Settings

Natural Gas - 1/4" open

Propane - 1/2" open

IMPORTANT: Run the fireplace for a minimum of 15 to 20 minutes to produce an accurate representation of the flame appearance. This warm-up should be done before and between any air shutter adjustment.

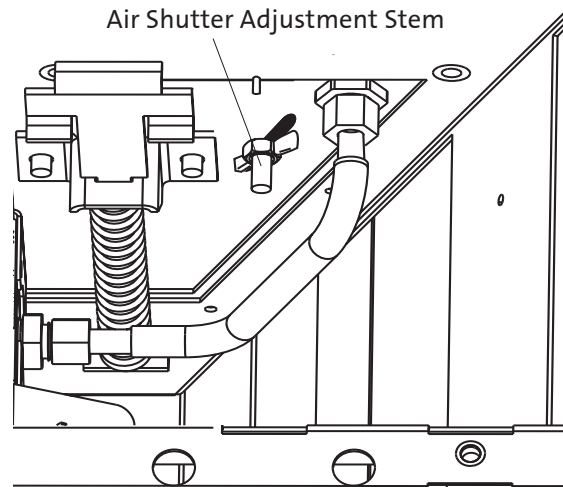

Figure 49. Air Shutter adjustment location.

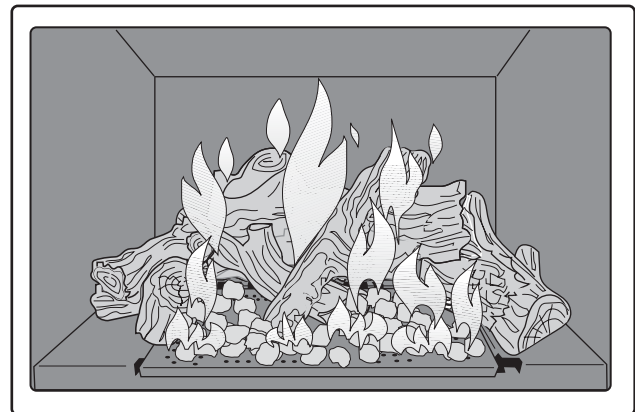

Figure 50. Proper flame pattern.

Operation

1. Your Acadia gas fireplace can be operated manually using the On/Off/T-stat rocker switch or it can be automatically controlled using an optional wall-mounted thermostat and/or remote control device. A separate switch is provided for the optional forced air blower kit.

Familiarize yourself with the location and function of the controls. See Figs. 51 and 52.

Gas Control - Used to control the Pilot light and gas flow from the supply line.

Regulator - Allows you to adjust heat output and flame intensity.

Piezo Ignitor - Push button pilot light ignition.

ON/OFF/ T'STAT Switch - Allows for manual or thermostatic control of the burner.

Always follow the Lighting Instructions located on the inside Back Cover of this manual.

2. For the first several hours of operation, it is common that you will detect some odor as the metal and manufacturing materials cure under heat. This condition is temporary and can be alleviated by allowing plenty of fresh air to circulate through the area.
3. Condensation may develop on the glass upon each lighting of the appliance. This "fog" will disappear as the glass heats.
4. Keep the controls and the area under the appliance free of debris; vacuum this area frequently. Always keep the appliance area clear and free from combustible materials, gasoline and other flammable liquids.

When a vacuum is used on any service for the fireplace, ALWAYS be sure the fireplace is completely cold.

5. Remember, your fireplace utilizes a continuously burning pilot flame. Exercise caution when using household products containing combustible vapors.
6. **CAUTION: DO NOT OPERATE THIS APPLIANCE WITH THE GLASS REMOVED, CRACKED OR BROKEN. REPLACEMENT OF THE GLASS SHOULD BE DONE BY A LICENSED OR QUALIFIED SERVICE PERSON. USE ONLY REPLACEMENT GLASS PROVIDED BY YOUR AUTHORIZED JØTUL DEALER. NEVER USE ANY SUBSTITUTE MATERIALS.**

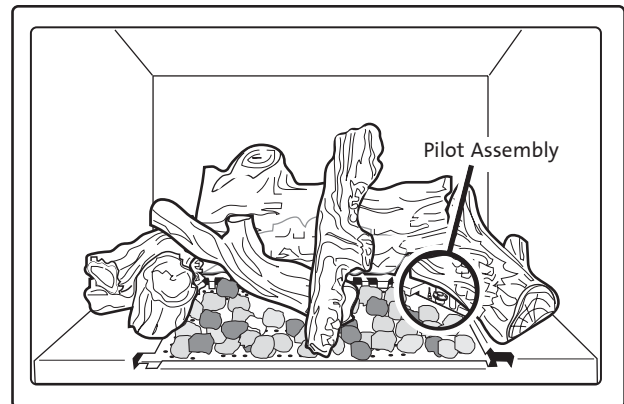

Figure 51. The pilot assembly is located at the right rear corner of the burner plate under the right log.

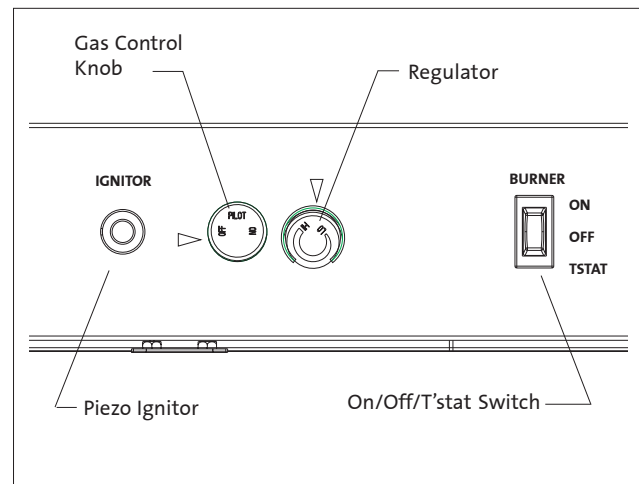

Figure 52. Burner Controls.

WARNING:
OBSERVE CAUTION NEAR THE GLASS PANEL. THE GLASS MAY SHATTER WHEN STRUCK BY AN OBJECT. ALWAYS HANDLE THE GLASS PANEL WITH CARE.

Maintenance

The Acadia gas fireplace and its venting system should be inspected before use and at least annually by a qualified service technician.

IMPORTANT:

ALWAYS TURN OFF THE GAS SUPPLY TO THE FIREPLACE AND UNPLUG THE FORCED AIR BLOWER BEFORE ANY SERVICE WORK IS PERFORMED ON THE FIREPLACE.

General Cleaning

The firebox should be vacuumed annually to remove any surface build up. Use a soft brush attachment and handle the logs carefully as they are fragile. Be sure to vacuum or wipe off the pilot assembly and burner orifice and burner tube.

Glass Care

Clean the glass only when necessary. Wipe the surface with a clean, dampened, soft cloth. Follow with a dry, soft towel. Take care not to scratch the glass surface.

WARNING:

DO NOT USE ABRASIVE CLEANERS ON THE GLASS. NEVER CLEAN THE GLASS WHEN IT IS HOT.

Gasket Inspection

It is important that the glass gasket be inspected at least annually. Examine the ribbon gasket for signs of deterioration and make sure the gasket has a positive seal. Replace the gasket if necessary. Refer to the replacement parts list on page 28.

Glass Panel or Gasket Removal

1. Open the Lower Grill Panel.
2. Release the glass clips at either side of the bottom of the firebox.
3. Swing the bottom of the glass frame out and lift to disengage it from the three retainer tabs at the top of the firebox.
4. Lay the assembly on a flat surface and carefully lift the metal tabs that secure the glass panel to the frame. Remove the old gasket material.
5. Install the new glass panel and gasket in the glass frame and secure with metal tabs. Do not over tighten tabs as that may damage the glass.

ONLY USE JØTUL AUTHORIZED PARTS. NEVER SUBSTITUTE NON-JØTUL PARTS ON THIS FIREPLACE.

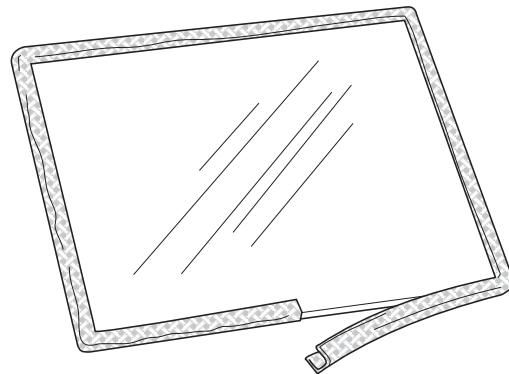

Figure 53. Replacing the glass gasket.

RETAIN THIS MANUAL FOR REFERENCE AND MAKE IT AVAILABLE TO ANYONE USING OR SERVICING THE FIREPLACE.

MODEL NAME: GZ 550 DV Acadia Gas Fireplace

SERIAL NUMBER:_____

DATE OF PURCHASE:_____

AUTHORIZED DEALER:_____

NAME OF INSTALLER:_____

TYPE OF FUEL:_____

WAS FIREPLACE CONVERTED?_____

NOTES:

SERVICE LOG:

First Year

Name of Technician_____

Company Name_____

Date of service_____

Work Performed_____

SERVICE LOG:

Second Year

Name of Technician_____

Company Name_____

Date of service_____

Work Performed_____

SERVICE LOG:

Third Year

Name of Technician_____

Company Name_____

Date of service_____

Work Performed_____

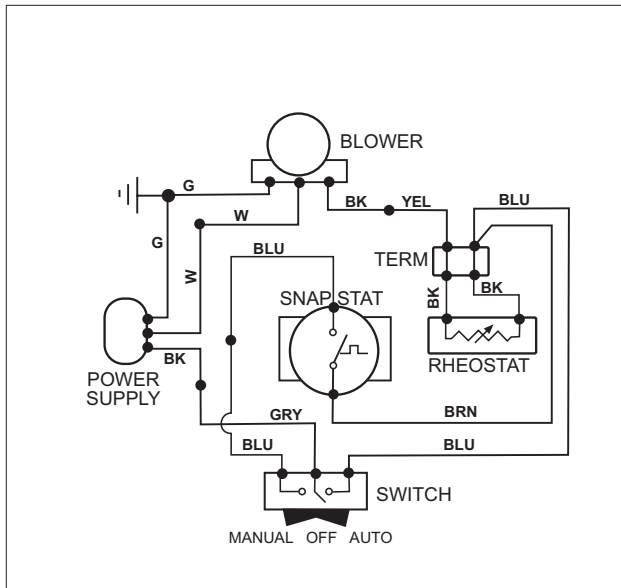
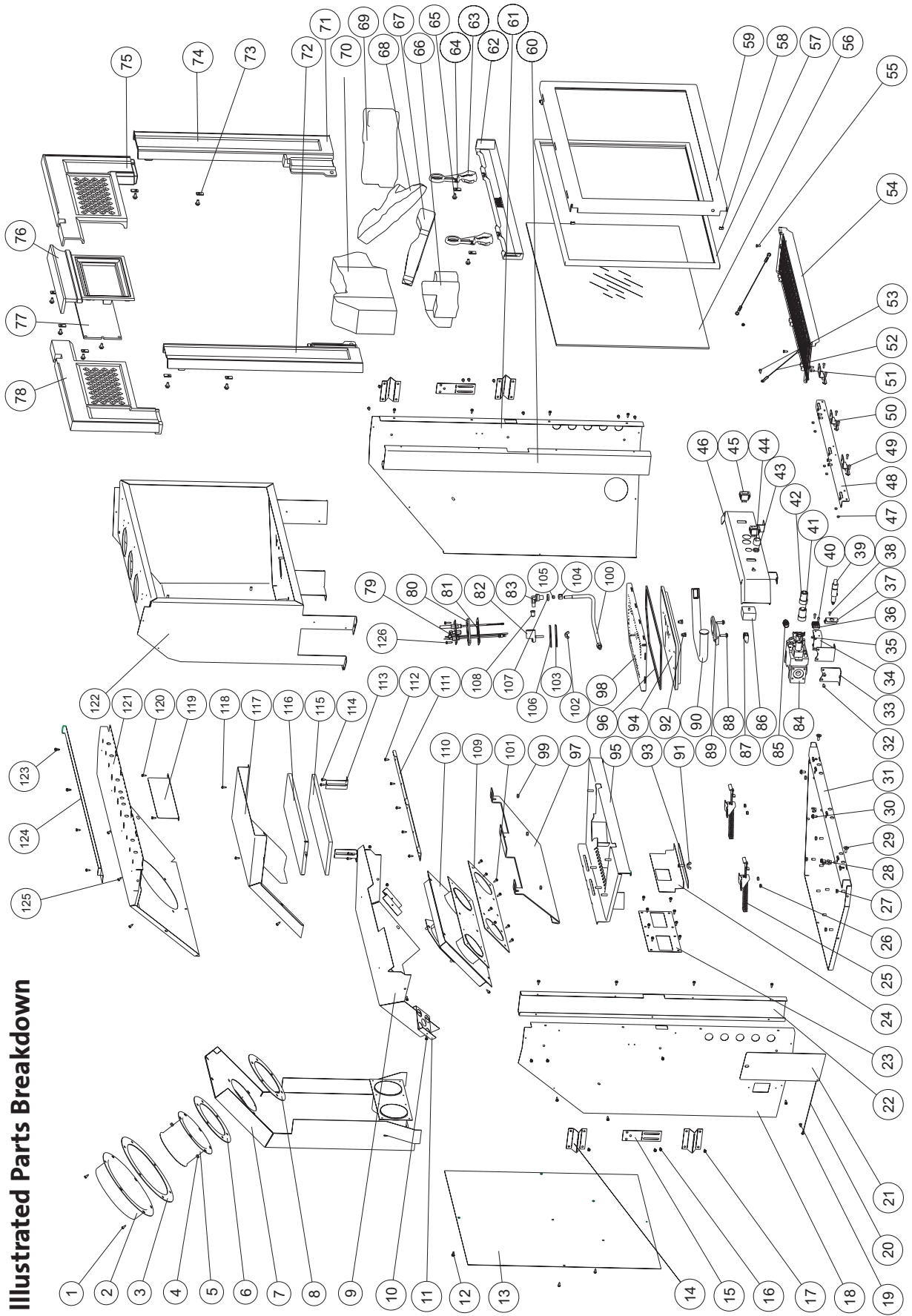

Figure 54. ZG550 DV Acadia Blower Wiring Diagram

GZ550DV II Acadia Illustrated Parts Breakdown



GZ 550 DVII Acadia Parts

No.	Description	Part Number
1.	Screw, #8 x 1/2 Sheet metal	117917
2	Adaptor, 8"	129784
3.	Gasket, 8" Adaptor	129775
4.	M6 Hex Nut	9930
5.	Adaptor, 5"	129782
6.	Gasket, 5" Adaptor	129774
7.	Air Intake Manifold	220952
8.	Gasket, 5" Adaptor	129774
9.	Top Shroud, Level 1	220955
10.	Screw, #8 X 1/2" Sheet metal	117917
11.	Support Bracket	220964
12.	Screw, #8 x 1/2 Sheet metal	117917
13.	Cabinet Wall, Rear	220961
14.	Stand-ott, 1" Framing	220969
15.	Wallstud Brace	220011
16.	Screw, #8 x 1/2 Sheet metal	117917
17.	Screw, #8 x 1/2 Sheet metal	117917
18.	Cabinet Wall, Left	220959
19.	Rivet, .125 x .250	117946
20.	Lanyard, .062 Wire (Rating Plate)	129159
21.	Rating Plate	220913
22.	Cool Air Channel	220957
23.	Air Intake Gasket	129773
24.	Air Intake Restrictor Plate	220963
25.	Latch Assembly	220049
26.	M6 Hex Nut	9930
27.	M6 Hex Nut	9930
28.	M6 Wingnut	117975
29.	M6 x 12 Flat Head Phillips Screw	117967
30.	M6 x 12 Hex Bolt	117130
31.	Cabinet Base	220958
32.	10-32 x 3/8 Phillips Screw	117911
33.	Valve Bracket	220945
34.	Terminal Block Bracket	220930
35.	M4 Hex Nut	117922
36.	Terminal Block, 2 Pole	129154
37.	Igniter Bracket	129679
38.	M4 x 8 Phillips Screw	117920
39.	Ignitor	3902573
40.	M4 x 12 Phillips Screw	117921
41.	Knob Extension, On/Off	129729
42.	Knob Extension, Hi/Lo	129730
43.	Rheostat Nut	220717
44.	Knob, Rheostat Control	220709
45.	On / Off Switch	220703
46.	Controls Board	220944
47.	M4 Hex Nut	117922
48.	Hinge Adaptor	12979392
49.	M4 x 10 Hex Bolt	117921
50.	Control Door Hinge	901043
51.	M5 x 10 Screw	117970
52.	Lanyard, .062 Wire - Control Door	220574
53.	Screw, #8 x 1/2 Sheet metal	117917
54.	Control Door - Matte Black	10395892
	Control Door - Blue Black	10395827
	Control Door - Jøtul Iron Gray	10395885
55.	M5 x 10 Screw	117970
56.	Ceramic Glass, Replacement (inc. gasket)	154987
57.	Gasket, Glass Tadpole	129124
58.	Glass Clip, Tinnerman	220042
59.	Glass Frame	129757
60.	Cool Air Channel	220957
61.	Cabinet Wall, Right	220960
62.	Fettle, Blue Black Enamel	11039627
63.	Andiron, Blue Black Enamel	10396727
64.	Hang Tab	129680
65.	M6 x 12 Hex Bolt	11730
66.	Log, Left	220993
67.	Log, Front	220995
68.	Log, Cross-over	220701
69.	Log, Right	220994
70.	Log, Rear	220992
71.	Surround Leg, Right / Matte Black	10395792
	Surround Leg, Right / Blue Black	10395727
	Surround Leg, Right / Jøtul Iron	10395785
72.	Surround Leg, Left / Matte Black	10395992
	Surround Leg, Left / Blue Black	10395927
	Surround Leg, Left / Jøtul Iron	10395985
73.	Hang Tab	129680
74.	M6 x 12 Hex Bolt	11730
75.	Surround Breastplate, Right / Matte Black	10395692
	Surround Breastplate, Right / Blue Black	10395627
	Surround Breastplate, Right / Jøtul Iron	10395685
76.	Surround Keystone / Matte Black	10395592
	Surround Keystone / Blue Black	10395527
	Surround Keystone / Jøtul Iron	10395585
77.	Tablet / Matte Black	10396692
	Tablet / Blue Black	10396627
	Tablet / Jøtul Iron	10396685
78.	Surround Breastplate, Left / Matte Black	10395492
	Surround Breastplate, Left / Blue Black	10395427
	Surround Breastplate, Left / Jøtul Iron	10395485
79.	Pilot Assembly - NG	129471
80.	Spacer, Pilot Assembly	220546
81.	Gasket, Pilot Assembly	129670
82.	Primary Air Shutter Assembly	220790
83.	Orifice Holder	129668
84.	Gas Valve - NG (50% TD)	220520
85.	Compression Nipple, 3/8 NTP - 5/16	220044
86.	Rheostat Assembly	155831
87.	Wire Harness Assembly	155830
88.	M6 x 20 Hex Bolt	117117
89.	Tube Holder, Cast Iron	155612
90.	Venturi Tube	155612
91.	M6 Wingnut	117975
92.	M6 AS Series Fastener	155612
93.	Gasket, Air Intake Restrictor	220987
94.	Burner Base, Cast Iron	155612
95.	Subfloor - Burner Skirt	220783
96.	Gasket, Burner	155612
97.	Exhaust Baffle	220954
98.	Burner Plate Assembly	155612
99.	M6 Hex Nut	9930
100.	Flex Tube, 5/16" x 14"	129390
101.	#8 x 1/2" Sheet metal Screw	117917
102.	M6 Wingnut	117975
103.	Cover Plate, Primary Air Restrictor	220388
104.	Compression Nut - 5/16	129464
105.	Compression Sleeve - 5/16	129463
106.	Gasket, Cover Plate	220395
107.	Jam Nut	129152
108.	Orifice, #38 - NG	129130
	Orifice, 1.55 - LP	220048
109.	Gasket, Heat Exchanger	129673
110.	Heat Exchanger	220950
111.	Glass Frame Hanger	129760
112.	#8 x 1/2" Sheet metal Screw	117917
113.	Relief Door Guide	220004
114.	#8 x 1/2" Sheet Metal Screw	117917
115.	Gasket, Relief Door	129772
116.	Relief Door	129759
117.	Top Shroud, Level 2	220956
118.	#8 x 1/2" Sheet Metal Screw	117917
119.	Keystone Heat Shield	220009
120.	#8 x 1/2" Sheet Metal Screw	117917
121.	Cabinet Top	220962
122.	Firebox	220947
123.	#8 x 1/2" Sheet Metal Screw	117917
124.	Sheetrock Standoff	220789
125.	#8 x 1/2" Sheet Metal Screw	117917
126.	#8 x 3/4" Sheet Metal Screw	117986
127.	Air Deflector, Burner Skirt	221102
128.	Ember Stones, 4 oz. *	220702
129.	Thermocouple *	129766
130.	Electrode *	129765
131.	Thermopile *	3094527

* not illustrated

GZ 550 DV II Optional Accessories

- Antique Brick Kit 155805
- Variable Speed Blower, 125 / 60 c.f.m. 155630
- 4" x 6-5/8" Adaptor Kit 154974
- High Altitude Conversion Kit - NG 155610
- High Altitude Conversion Kit - LP 155611
- Fuel Conversion Kit - LP 155594
- Fuel Conversion Kit - NG 155595
- Wall Thermostat 750003
- Remote Control 129706
- **QuickFace Fronts w/ Screen**
 - Steel Rectangular, Matte Black 154964
 - Steel Arch, Matte Black 154965
 - Brushed Stainless Steel, Rectangular 154968
 - Brushed Stainless Steel Arch 154969
- Arched Double Doors, Matte Black 350560
- Arched Double Doors, Blue Black 350561
- Double Door Basket Screen 154973

LIGHTING INSTRUCTIONS

FOR YOUR SAFETY, READ BEFORE LIGHTING.

WARNING:

IF YOU DO NOT FOLLOW THESE INSTRUCTIONS EXACTLY, A FIRE OR EXPLOSION MAY RESULT CAUSING PROPERTY DAMAGE, PERSONAL INJURY, OR LOSS OF LIFE.

- A.** This appliance has a pilot which must be lit by hand. When lighting the pilot, follow these instructions exactly.
- B. BEFORE LIGHTING,** smell all around the appliance area for gas. Be sure to smell next to the floor because some gas is heavier than air and will settle to the floor.
- WHAT TO DO IF YOU SMELL GAS:**
- Extinguish any open flame.
 - Open windows.
 - Do not light any appliance.
 - Do not touch any electrical switches.
 - Do not use any phone in your building.
 - Immediately call your gas supplier from a neighbor's phone.
- If your gas supplier cannot be reached, call the fire department.
- C.** Use only your hand to push in or turn the gas control knob. Never use tools. If the knob will not push in or turn by hand, do not try to repair it. Call a qualified technician. Force or attempted repair may result in a fire or explosion.
- D.** Do not use this appliance if any part has been under water. Immediately call a qualified service technician to inspect the appliance and to replace any part of the control system and any gas control which has been under water.

LIGHTING INSTRUCTIONS

1. STOP! Read the safety information above.
2. Access the lower controls.
3. Turn the stove ON/OFF switch to "OFF", or set the thermostat to lowest setting (if used).
4. Confirm that the gas supply line shut-off valve is open.

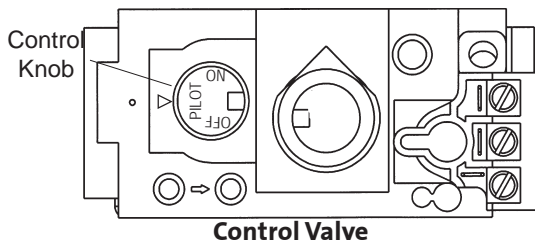

5. Push in gas control knob slightly and turn clockwise ➡ to "OFF".
NOTE: Knob cannot be turned from "PILOT" to "OFF" unless the knob is pushed in slightly. Do not force.
6. Wait five (5) minutes to clear out any gas. If you then smell gas, STOP! Follow "B" in the safety information above on this page. If you do not smell gas, go to the next step.

7. Push in gas control knob slightly and turn counterclockwise ↶ to "PILOT".
8. Push in control knob all the way and hold in. Immediately light the pilot by triggering the spark ignitor (push the red button repeatedly) until pilot lights. Continue to hold the control knob in for about one minute after the pilot lights. Release knob and it should spring back. The pilot should remain lit. If it goes out, repeat Steps 5 through 8.

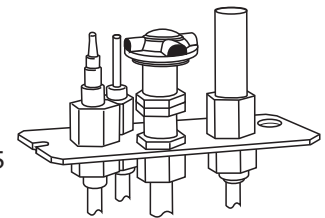

- If knob does not return when released, stop and immediately call your service technician or gas supplier.
 - If pilot will not stay lit after several tries, turn the control knob to OFF and call your service technician or gas supplier.
9. Turn gas control knob counterclockwise ↶ to "ON".
 10. Turn the stove ON/OFF switch to "ON", or set thermostat (if used) to desired temperature.

TO TURN OFF GAS TO THE APPLIANCE:

1. Turn ON/OFF switch to "OFF". The pilot will remain lit for normal service.
2. For complete shutdown, turn ON/OFF switch to "OFF".
3. Access the lower controls.
4. Depress gas control knob slightly and turn clockwise ➡ to "OFF". Do not force.

July 2006
137950-B

This appliance must be installed in conformance with local and national building regulations. Before beginning the installation, it is important that these instructions be carefully read and understood. Jøtul maintains a policy of continual product development. Consequently, products may differ in specification, color or type of accessories from those illustrated or described in various publications.

Jøtul vise sans cesse à améliorer ses produits. C'est pourquoi, il se réserve le droit de modifier les spécifications, couleurs et équipement sans avis préalable.



Jøtul AS
P.O. Box 1411
N-1602 Fredrikstad
Norway

Jøtul North America
55 Hutcherson Dr.
Gorham, ME 04038-2634