

**Jøtul F 370 U.S.  
Woodburning Stove**



# Jøtul F 370 Woodburning Stove

Installation and Operating Instructions  
for the United States & Canada



Keep these instructions for future reference.

### For Your Records...

Record the following information to help your dealer determine what you will need should your fireplace ever require parts or service.

The serial number and manufacturing date are located on the aluminum label attached to the bottom of the firebox. Attach your sales receipt to this manual for future reference.

Model: Jøtul F 370 Serial Number: \_\_\_\_\_

Purchase Date: \_\_\_\_\_

Dealer Name: \_\_\_\_\_

\_\_\_\_\_

\_\_\_\_\_

Installed by: \_\_\_\_\_

**NOTICE:**

**CONSULT THE AUTHORITY HAVING JURISDICTION IN YOUR LOCALE (SUCH AS MUNICIPAL BUILDING DEPARTMENT, FIRE DEPARTMENT, FIRE PREVENTION BUREAU, ETC.) BEFORE INSTALLATION TO DETERMINE THE NEED TO OBTAIN A PERMIT.**



We suggest that our woodburning hearth products be installed and serviced by professionals who are certified in the U.S. by the National Fireplace Institute® (NFI) as NFI Woodburning Specialists or who are certified in Canada by Wood Energy Technical Training (WETT).



## Table of Contents

- 1. Standards and Codes ..... 3**
- 2. Specifications ..... 4**
- 3. Safety Requirements ..... 5**
- 4. Installation**
  - 4.1 Chimney Requirements ..... 5
  - 4.2 Chimney Connector Requirements ..... 7
  - 4.3 Floor Protection ..... 10
  - 4.4 Clearance to Combustible Materials ..... 10
- 5. Assembly**
  - 5.1 Tools & Materials ..... 12
  - 5.2 Unpacking the Stove ..... 12
  - 5.3 Install Anchor Bracket ..... 12
  - 5.4 Assemble the Firebox and Pedestal ..... 13
  - 5.5 Position the Stove ..... 14
  - 5.6 Chimney Connection ..... 14
  - 5.7 Secure Stove to Hearth ..... 15
  - 5.8 Final Assembly ..... 15
- 6. Operation**
  - 6.1 Fuel ..... 16
  - 6.2 Air Control Settings ..... 16
  - 6.3 Starting a Fire ..... 17
  - 6.4 Break-in Procedure ..... 17
  - 6.5 Adding Fuel ..... 17
  - 6.6 Creosote Formation ..... 18
- 7. Maintenance**
  - 7.1 Ash Removal ..... 19
  - 7.2 Chimney System Inspection ..... 19
  - 7.3 Glass Care ..... 19
  - 7.4 General Maintenance ..... 20
  - 7.5 Gaskets ..... 20
- 8. Illustrated Parts & Listing ..... 21**
- 9. Warranty Statement ..... 23**

## Installation and Operation Instructions for USA/Canada

**Safety notice:** If this solid fuel room heater is not properly installed, a house fire may result. For your safety, follow the installation directions. Contact local building or fire officials about restrictions and installation inspection requirements in your area. Save these instructions for future reference and make them available to anyone using or servicing this stove.

## Installation et fonctionnement pour Canada

**Avis de sécurité:** Une installation non appropriée de ce poêle de chauffage risque de provoquer un incendie. Assurez votre sécurité en respectant les directives d'installation suivantes. Consultez les autorités locales du bâtiment ou de la prévention des incendies au sujet des restrictions et exigences relatives aux inspections d'installations dans votre région.

**This heater meets the U.S. Environmental Protection Agency's Phase II emissions limits for wood heaters manufactured and sold after July 1, 1990.**

## 1. Standards & Codes

### 1.1 Test Standards

The Jøtul F 370 Solid Fuel Room Heater has been tested for compliance with the applicable requirements of the following standards:

UL 1482-2000 "Solid-Fuel Type Room Heaters" and ULC S627-2000 "Standard for Space Heaters for use with Solid Fuels".

Tested and listed by Warnock Hersey - Intertek Testing Services, Middleton, Wisconsin.



### 1.2 Check Building Codes

When installing, operating and maintaining your Jøtul F 370 Fireplace Insert, follow the guidelines presented in these instructions, and make them available to anyone using or servicing the stove.

**In the U.S.:** guidelines established by UL 1777, the National Fire Protection Association's Code, NFPA 211, Standards for Chimneys, Fireplaces, Vents and Solid Fuel Burning Appliances, or similar regulations, may apply to the installation of a solid fuel burning appliance in your area. For further information on using your heater safely, obtain a copy of the NFPA publication "Using Coal and Wood Stoves Safely," NFPA No. HS-8-1974, available from NFPA

470 Atlantic Ave.  
Boston, MA 02210.

**In Canada,** the guidelines are established by ULC-S635, and the CSA Standard, CAN/CSA-B365-M93, Installation Code for Solid-Fuel-Burning Appliances and Equipment.

Always consult your local building inspector or authority having jurisdiction to determine what regulations apply and what permits may be required before installation of a solid fuel-burning appliance.

Notify your insurance company before installing this stove.

## 2. Specifications

- Heat Output: 18,700 BTU/hr.
- Efficiency: 73%
- Emissions: 2.58 g/hr.
- Log Length, max. 12 in. / 300 mm
- Flue Outlet: Top or Rear Exit
- Flue Outlet Adaptor Dia: 6 in. / 153 mm
- Weight: 344 lbs. / 156 kg

### Optional Equipment:

- Rotation Kit #350997

**THIS APPLIANCE IS NOT APPROVED FOR USE IN MOBILE HOMES.**

**This appliance is listed to burn natural wood and compressed wood bricks only. Do not burn other fuels.**

**Read this manual before you install and use your stove.**

Manufactured by:  
Jøtul AS  
Fredrikstad, Norway

Distributed by Jøtul North America, Inc.  
55 Hutcherson Dr.  
Gorham, ME 04036

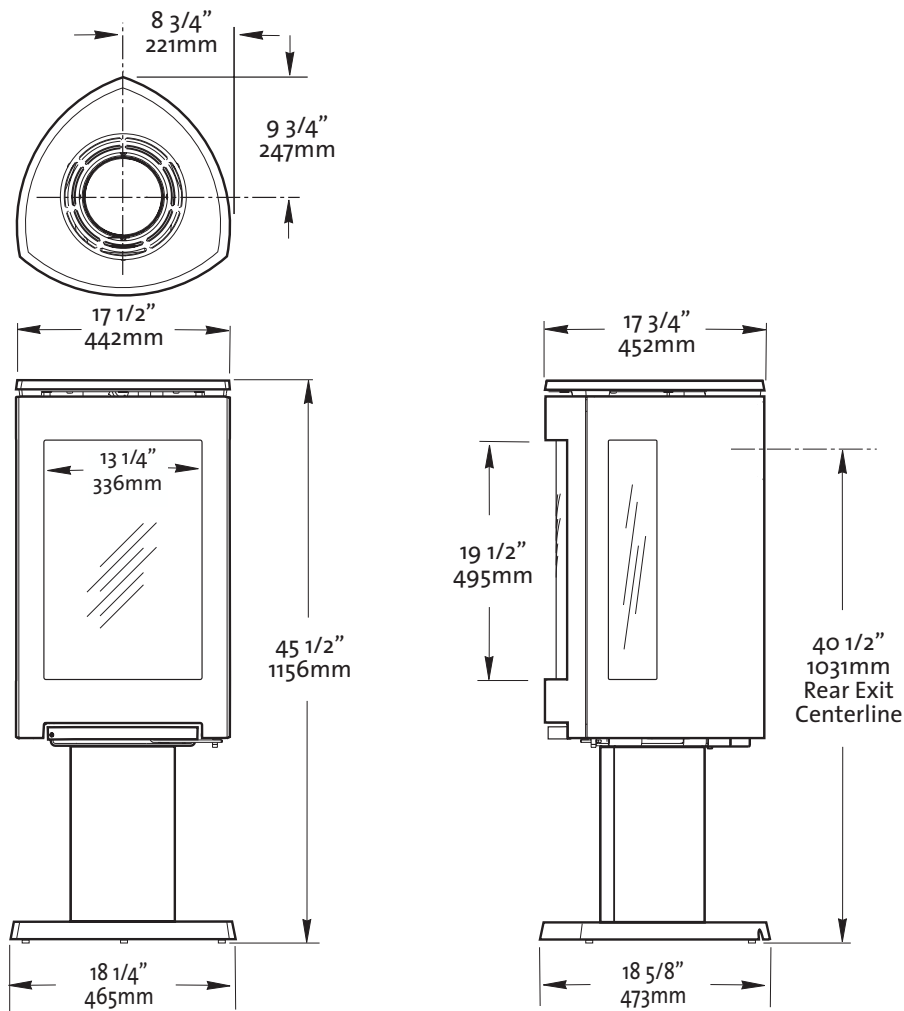

Figure 1. Jøtul F 370 critical dimensions.

### 3. Safety Notices

- BURN SOLID WOOD FUEL ONLY
- DO NOT USE CHEMICALS OR FLUIDS TO START THE FIRE. DO NOT BURN GARBAGE, TRASH, OR FLAMMABLE FLUIDS.
- IF THIS ROOM HEATER IS NOT PROPERLY INSTALLED, A HOUSE FIRE MAY RESULT. TO REDUCE THE RISK OF FIRE, FOLLOW THE INSTALLATION INSTRUCTIONS. FAILURE TO FOLLOW THESE INSTRUCTIONS MAY RESULT IN PROPERTY DAMAGE, BODILY INJURY, OR LOSS OF LIFE.
- CONTACT THE LOCAL BUILDING OR FIRE OFFICIALS ABOUT RESTRICTIONS AND INSTALLATION INSPECTION REQUIREMENTS IN YOUR AREA. WHEN NOT ADDRESSED IN THIS MANUAL, OR BY LOCAL CODE AUTHORITIES, INSTALLATION SPECIFICATIONS AND REQUIREMENTS DEFER TO NFPA 211 OR CSA B 365
- DO NOT CONNECT THIS FIREPLACE TO ANY AIR DISTRIBUTION DUCT OR SYSTEM .
- EXTREMELY HOT WHILE IN OPERATION! KEEP CHILDREN, CLOTHING AND FURNITURE AWAY. CONTACT WILL CAUSE SKIN BURNS.
- NEVER LEAVE SMALL CHILDREN UNSUPERVISED IN THE SAME ROOM WITH THE STOVE. USE A CHILD-GUARD SCREEN OR OTHER BARRIER TO PROTECT CHILDREN FROM ACCIDENTAL CONTACT.
- NEVER OPERATE THE FIREPLACE WITH A CRACKED OR BROKEN GLASS PANEL.
- Install smoke detectors in the living areas and bedrooms of your home. Test them regularly and install new batteries twice annually. When installed in the same room as the stove, a smoke detector should be located as far from the stove as possible to prevent it from sounding when adding fuel to the fire. Some jurisdictions require installation of CO (carbon monoxide) detectors. Check your local codes.
- Avoid creating a low pressure condition in the room where the stove is operating. Be aware that operation of an exhaust fan or clothes dryer can create a low pressure area and consequently promote flow reversal through the stove and chimney system. The chimney and building, however, always work together as a system - provision of outside air, directly or indirectly to an atmospherically vented appliance will not guaranty proper chimney performance. Consult your local Jøtul authorized dealer regarding specific installation or performance issues.

### 4. Installation Requirements

#### 4.1 Chimney Requirements

There are two types of approved chimneys:

1. A code-approved masonry chimney with a ceramic tile or listed steel flue liner.
2. A prefabricated chimney complying with the requirements for Type HT (2100°F) chimneys per UL103 HT or ULCS629 HT.

#### Chimney Flue Sizing

The chimney size should not be less than the cross-sectional area of the flue collar, and not more than three times greater than the cross-sectional area of the flue collar.

If the chimney flue is outdoors, its cross-sectional area may not exceed two times greater than the stove flue collar.

A chimney flue having no walls exposed to the outside below the roof-line may be no larger than three-times the cross-sectional area of the stove flue collar.

#### Design Considerations

When selecting a chimney type and the location for the chimney in the house, keep this in mind: **It is the chimney that makes the stove work - not the stove that makes the chimney work.** This is because a chimney actually creates a suction, called “draft” which pulls air through the stove.

Several factors affect draft: chimney height, cross-sectional area (size), and temperature of the chimney, as well as the proximity of surrounding trees or buildings.

A short exterior masonry chimney will give the poorest performance because it will be difficult to warm the flue and sustain the temperatures necessary to maintain draft strength. In extremely cold climates, it may be necessary to reline the chimney or extend the height to help establish draft.

A tall, interior masonry chimney is easier to keep warm and will perform the best under a variety of weather and environmental conditions.

The following guidelines give the necessary chimney requirements based on the national code (ANSI-NFPA 211 for the US. And CSA CAN-B365 for Canada). However, many local codes differ from the national code to take into account climate, altitude, or other factors. Your local building inspector is the final approving authority.

**Do not connect the stove to any air distribution duct or system.**

### 4.1.1 Masonry Chimneys

Follow these guidelines when installing the stove into a masonry fireplace:

- The masonry chimney must have a fireclay liner or equivalent, with a minimum thickness of 5/8" (14 mm) and must be installed with refractory mortar. There must be at least 1/2" (12.7 mm) air space between the flue liner and chimney wall.
- The fireclay flue liner must have a nominal size of 8" X 8" (20 cm x 20 cm), and should not be larger than 8"X 12" (20 cm x 30 cm). A round fireclay liner must have a minimum inside diameter of 6" (15 cm) and maximum inside diameter of 8" (20 cm). A larger chimney should be relined with an appropriate code approved liner.
- Brick or modular block must be a minimum of 4" (10 cm) nominal thickness. Stone construction must be at least 12" (30 cm) thick.
- A newly-built chimney must conform to local codes, or, in their absence, must comply with national regulations.
- An existing chimney must be inspected by a professional, licensed chimney sweep, fire official, or code officer to ensure that the chimney is in proper working order. Any repairs must be completed before installing the stove.
- No other appliance may be vented into the same flue.
- An airtight clean-out door should be located at the base of the chimney.

### 4.1.2 Prefabricated Chimneys

A prefabricated metal chimney must be tested and listed for use with solid fuel burning appliances; High Temperature Chimney Standard UL 103 HT for the U.S. and High Temperature Standard ULC S-629 HT for Canada.

The manufacturer's installation instructions must be followed precisely. Always maintain the proper clearance to combustibles as established by the pipe manufacturer. This clearance is usually a minimum of 2", although it may vary by manufacturer or for certain chimney components.

### 4.1.3 Chimney Height

The chimney must be at least 3 feet (92 cm) higher than the highest point where it passes through the roof and at least 2 feet (61 cm) higher than the highest part of the roof or structure that is within 10 feet (3.05 m) of the chimney, measured horizontally. See fig. 2.

Chimneys shorter than 14 feet (4.27 m) may not provide adequate draft. Inadequate draft can result in smoke spillage when loading the stove, or when the door is open. Poor draft can also cause back puffing (ignition of gas build-up inside the firebox) and sluggish performance. The minimum height does not, in itself, guarantee proper chimney performance. Optimum draft force should be in the .05 - .10 in. w.c. range measured by a Magnahelic gauge. Draft at .07 w.c. is ideal.

Excessive chimney height can promote over-strong draft resulting in high stove temperatures and short burn times. Excessive draft can be corrected by installing a butterfly damper. Your Jøtul dealer is an expert resource to consult regarding draft issues or other performance-related questions.

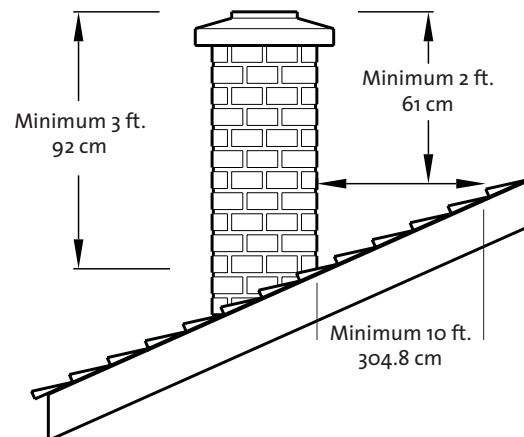

Figure 2. Chimney height requirements.

## 4.2 Chimney Connector Requirements

Use 6" single wall or listed 6" double-wall stovepipe to connect the stove to the chimney. Single wall stovepipe must be black steel or stainless steel and have a minimum thickness of 24 gauge.

Do not use aluminum or galvanized steel pipe for chimney connection - these materials are not suitable for use with solid fuel.

### Follow these guidelines:

- Do not use chimney connector as a chimney. It is intended only as a connection device.
- Each connector section must be oriented with the male (crimped) end pointing toward the stove. See fig. 3.
- Secure all connector joints with three sheet metal screws. Use four self-tapping sheet metal screws at the connection to the stove flue collar adaptor.
- For the best performance, the chimney connector should be as short and direct as possible, including no more than two 90° elbows.
- **The maximum vertical run of single wall stovepipe should not exceed 10 ft. (305 cm).**
- **The maximum horizontal run should not exceed 3 ft. (92 cm) with a 1/4" rise per foot.** Under no circumstance should horizontal pipe be allowed to slant down toward the chimney.
- No part of the chimney connector may pass through an attic or roof space, closet or other concealed space, or through a floor or ceiling. All sections of the chimney connectors must be accessible for cleaning. Where passage through a wall or partition of combustible construction is desired, the installation must conform with NFPA 211 or CAN/CSA-B365, and is also addressed in this manual.
- **Do not connect this stove to a chimney flue serving another heating appliance.**

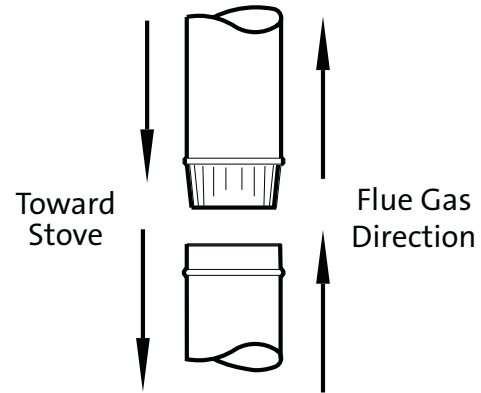

Figure 3. Chimney connector orientation.

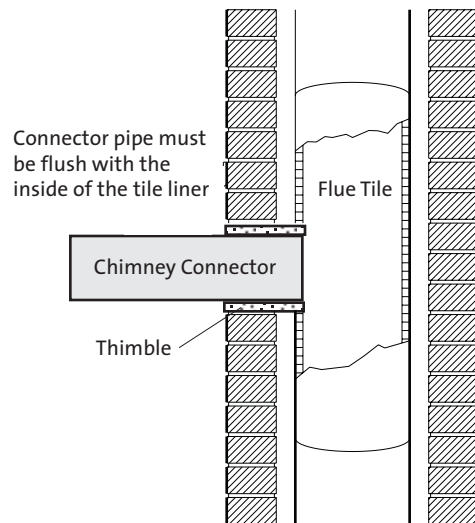

Figure 4. Masonry chimney connection through a thimble.

### 4.2.1 Connecting to the Chimney

#### Masonry Chimney

When installing a Stove into a masonry chimney through a "thimble" (the opening through the chimney wall to the flue), the thimble must consist of ceramic tile or steel and be securely cemented in place.

The chimney connector/stove pipe must slide completely inside the thimble to the inner surface or the flue liner. It may be necessary to make use of a thimble sleeve (a pipe with a slightly smaller diameter than standard stove pipe). See figs 4.

The connector pipe or thimble sleeve must not protrude into the flue liner or otherwise restrict draft.

Use refractory cement to seal the seam between the chimney connector, sleeve, and thimble.

**Do not connect this stove to a chimney flue servicing another appliance of any kind.**

### Prefabricated Chimneys

When connecting the stove to a prefabricated metal chimney, always follow the manufacturer's instructions and be sure to use all components that are required. This usually includes a "chimney connector adaptor" that is secured to the bottom section of the prefabricated chimney and allows the chimney pipe to be secured according to the manufacturer's specifications. See fig. 5.

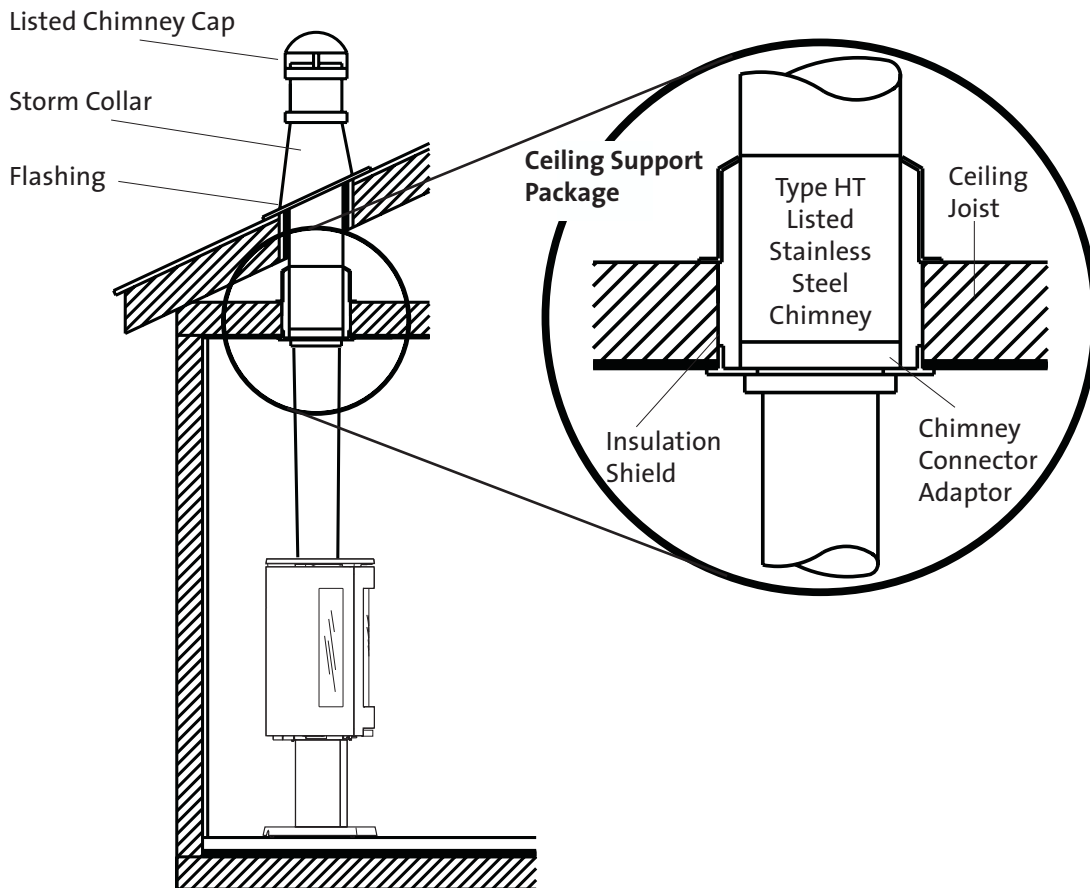

Figure 5. Connection to prefabricated chimney.

## 4.2.2 Wall Pass-Throughs

Note: In addition to the methods described here, any listed, prefabricated wall pass-through components available from chimney manufacturers may be used.

### In the U.S.

The National Fire Protection Association's publication, NFPA 211, *Standard for Chimneys, Fireplaces, Vents and Solid Fuel Burning Appliances* permits four methods for passing through a combustible wall. Before proceeding with any method be sure to consult with your local building officials to discuss any local code requirements.

#### Common Method:

See fig. 6 Remove all combustible materials from the pass-through area ( around the chimney connector), a minimum 12" (30.5 cm). A 6" (15.2 cm) diameter connector will require a 31 1/4" x 31 1/4" (79.4 x 79.4 cm) square opening.

The opening must be filled with at least 12" (30.5 cm) of brick around a fireclay liner. The liner must be ASTM C35 or equivalent, having a minimum wall thickness of 5/8" (16 mm).

The Pass-through must be at least 18" (45.7 cm) from combustible ceiling materials.

It will be necessary to cut wall studs, install headers, and construct a sill frame to maintain the proper dimensions and to support the weight of the brick.

The bricks must be solid brick with a minimum of 3 inches thick (nominal 4" / 102 mm).

Refractory mortar must be used at the junction of the chimney and the pass-through liner. The pass-through liner must not penetrate the chimney liner beyond the inner surface of the chimney liner. Use extreme care when constructing the hole in the chimney liner as the tiles can shatter easily.

### In Canada

The installation must conform to CAN/CSA-B365, Installation Code for Solid Fuel Burning Appliances and Equipment. Before proceeding be sure to consult your local building inspector.

#### Common Method:

This method requires the removal of all combustible materials from at least 18" (45.7 cm) around the chimney connector's proposed location. A 6" round liner requires a minimum opening 43 1/4" x 43 1/4" (109.8 x 109.8cm) square.

Locate the pass-through at least 18" from combustible ceiling materials.

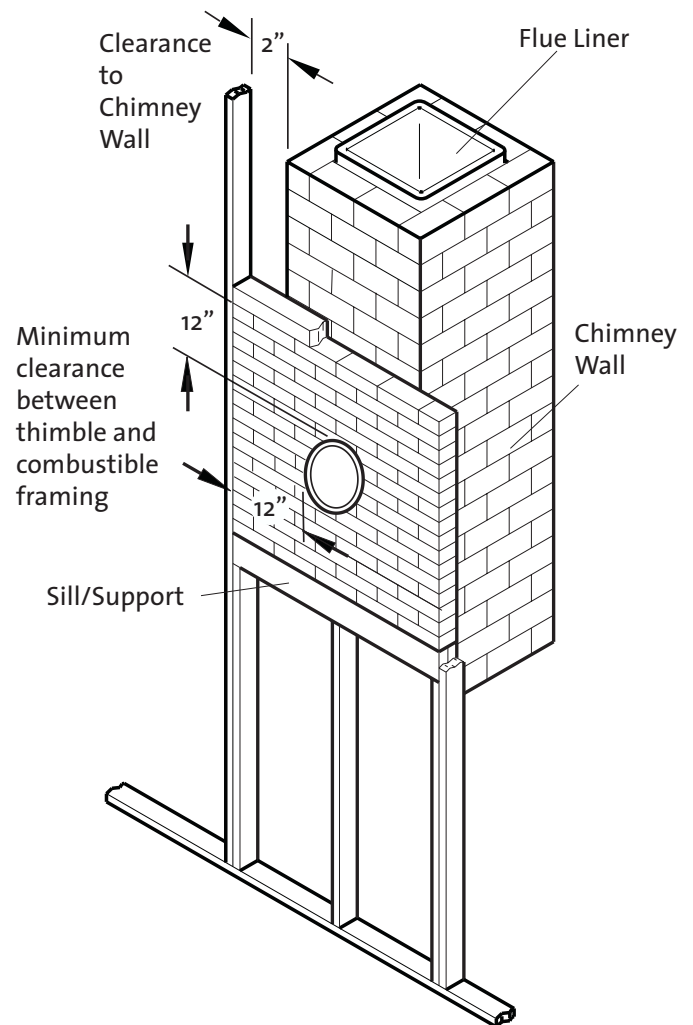

Figure 6.  
Chimney connection to masonry chimney.

The space that is cleared of combustible materials must remain empty. Sheet metal panels can be used to cover the area. However, when using a panel on both sides of the wall, each cover must be installed on noncombustible spacers at least 1" from the wall. If one panel of sheet metal is to be used it may be installed flush to the wall.

See section 5.3.1 and 5.3.2 of CAN/CSA - B365-M91.

Consult your local building inspector, authorized Jøtul Dealer, NFPA 211 in the U.S. or CAN/CSA-B365 in Canada for other approved wall pass-through methods.

### 4.3 Floor Protection

Any floor that is not composed of concrete poured on earth requires protection from sparks and embers. The Jøtul F 370 is approved for installation using one of the following forms of hearth protection:

- 1) Any UL, ULC, or Warnock Hersey Listed Type 1 hearth board.
- 2) Any noncombustible material.

**In the U.S.** floor protection must extend forward from the door opening at least 16 in. and 8 in. from the sides of the door opening. Protection must also extend 2 in. under the chimney connector. This will result in a minimum floor protector 29 1/2" wide x 33 3/4" deep. See fig.7.

**In Canada,** floor protection must extend 18" from the front of the stove and 8 in. (460mm) from the sides. It must also extend 2 in. (51 mm) under the chimney connector. This results in a floor protector 33 1/2 in. x 35 3/4 in. (851 mm x 908 mm) See fig.7.

If the optional Rotator Kit is to be used, floor protection must extend to accommodate the area of rotation. Consult the instructions that are provided with that kit.

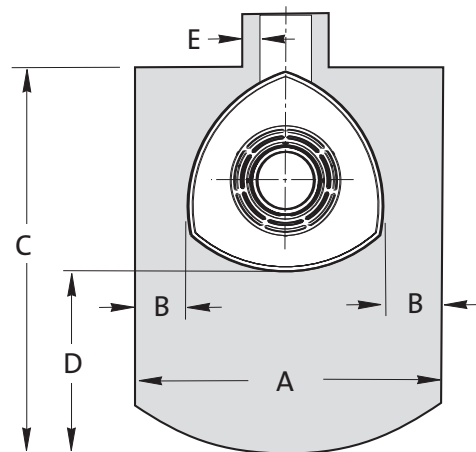

	A	B	C	D	E
U.S.	29 1/2"	8" *	33 3/4"	16"	2" 51mm
CAN.	33 1/2" 851 mm	8" 203 mm	35 3/4" 908 mm	18" 457 mm	

\* measured from the door opening - U.S. only

Figure 7. Floor protection dimensions.

### 4.4 Clearance to Combustible Materials

The clearances listed and diagramed in this manual have been tested to UL and ULC standards and are the minimum clearances to combustible materials specifically established for the Jøtul F 370.

- A combustible surface is anything that can burn (i.e. sheet rock, wall paper, wood, fabrics etc.).
- Any combustible material must be kept 36" (914mm) away from the stove load door and at least 18" (457mm) from the sides.
- Combustible materials are not limited to those that are visible and also include materials that are behind noncombustible materials. "Fire Resistant" or "Fire-rated" materials are considered combustible; they are difficult to ignite, but will burn.
- Consult your local fire officials if you are unsure of the combustible nature of any material.

#### 4.4.1 Clearance to Walls & Ceilings

See the table in fig.8. for specific wall clearance requirements using either single or listed double-wall connectors.

##### ROTATION KIT NOTE:

If the Rotation Kit will be used, install the stove in accordance with the clearance specifications noted in the instructions supplied with that kit. The clearances in fig. 8 do not take the rotation feature into account.

Minimum Ceiling Height: 72" / 183 cm

The F 370 is approved for use with Listed double wall pipe installed to conform to the clearances in fig. 8.

**Wall-Mounted Protection:** When reducing clearances through the use of wall-mounted protection:

**For the U.S. , refer to NFPA 211, Standard for Chimneys, Fireplaces, Vents and Solid Fuel Burning Appliances,** for acceptable materials, proper sizing and construction guidelines.

**For Canada, refer to CAN/CSA-B365, Installation Code for Solid-Fuel Burning Appliances and Equipment,** also for acceptable materials, proper sizing and construction guidelines.

**Notice:** Many manufacturers have developed woodstove accessories that permit clearance reduction. Use only those accessories that have been tested by an independent laboratory and carry the laboratory's testing mark. Be sure to follow all of the manufacturer's instructions.

THIS CHART IS NOT VALID FOR ROTATION KIT INSTALLATION. See instructions included with that kit.	UNPROTECTED WALLS			PROTECTED WALLS PER NFPA211 OR CAN/CSA -B365-M93		
	SIDE	REAR	CORNER	SIDE	REAR	CORNER
<b>Single Wall Connector</b>	A 22" / 560 mm	B 12" / 305 mm	C 16" / 406 mm	D 12" / 305 mm	E 12" / 305 mm	F 8.5" / 216 mm
<b>Double Wall Connector</b>	G 22" / 560 mm	H 6" / 152 mm	I 16" / 406 mm	J 9" / 229 mm	K 4" / 102 mm	L 6" / 152 mm
<b>Alcove w/ Double-Wall Connector</b>	N/A	N/A	N/A	M 12" / 305 mm	N 7" / 178 mm	N/A

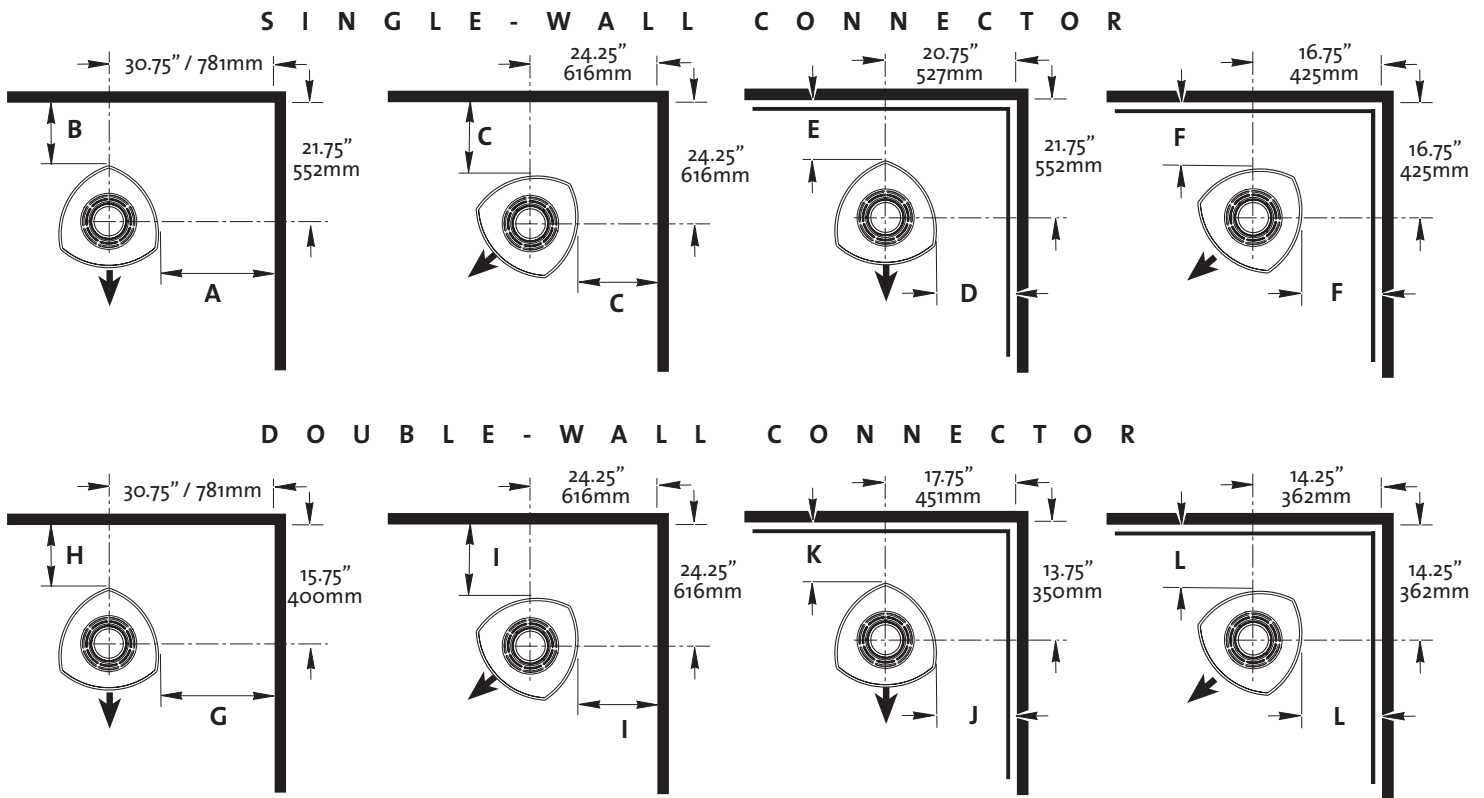

Figure 8. Clearance Diagrams. All specifications applicable to both top and rear exit configurations.

#### 4.4.2 Alcove Installations

The Jøtul F 370 can be installed in an alcove as diagrammed in fig. 9. Use of the Rotation Kit is not permitted in an Alcove.

1. The stove must be installed only with double-wall chimney connector.
2. Wall protection must extend over the entire area.
3. Alcove floor protection must consist of a UL/ULC or WHI listed Type 1 hearth pad or a non combustible material.
4. Minimum Alcove Ceiling Height: - 72" / 183 cm  
No alcove ceiling clearance reduction is permitted.

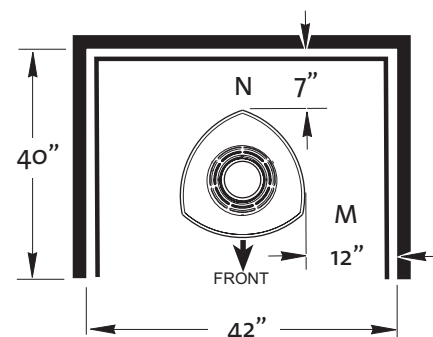

Figure 9. Alcove clearance requirements.

## 5. Assembly

### 5.1 Tools & Materials

- work gloves
- safety glasses
- tape measure
- 4 mm hex key
- power drill w/ 1/4" and 3/8" drill bits
- 3/8" or 10 mm open end or socket wrench
- 9/16" or 14 mm socket wrench
- ball peen hammer (Rear Exit connection only)

### 5.2 Unpacking the Stove

This product includes three boxes shipped on two pallets:

- 351006 Pedestal Assembly
- 351005 Firebox Assembly - attaches to the Pedestal Assembly
  - includes a decorative Flue Outlet Cover Plate (for use with a rear exit chimney connection), two cast iron Burn Plates, and a stove glove inside the Ash Pan.
- 157373 Anchor Bracket / Outlet Adaptor Kit

#### THE PEDESTAL AND FIREBOX ASSEMBLIES ARE HEAVY!

Be sure to have assistance available when assembling and installing this stove.

Inspect each assembly and immediately report any damage to your local dealer.

1. **From the bottom of the Pedestal Assembly**, remove and discard the foam doughnut gasket. It will not be used.
2. **From the Firebox Assembly:**  
Remove the Air Outlet Grille and Top Plate from the stove. These simply lift off the main body.  
Remove the Baffle Plate, both Side Panels, Rear Panel, Shaker Grate, Bottom Plate, and Ash Pan from inside of the firebox. See fig. 21 and parts list on pages 21-22.
3. **Only if the Rear Exit flue connection is to be used:**
  - Drill a hole at the two dimple locations in the cut-out panels at the back of the stove (fig. 10, A).
  - Place the wooden wedge (fig. 10, B) supplied in the firebox as shown to support the side plates when the outlet cut-outs are removed.
  - Use a ball peen hammer to knock out the panels from the back of the stove.

#### **Important!**

*If the optional Rotation Kit will be used, it must be installed now, before the firebox and pedestal are joined. Consult the assembly instructions provided with that kit.*



Figure 10. Removing the rear exit outlet knock-outs.

### 5.3 Attach the Anchor Bracket to the Pedestal Base

1. Use a 4 mm hex key to remove the two countersunk screws and cover plate from the pedestal base. See fig. 11.
2. Place the pedestal on its side and use the two, M6 x 20 mm hex bolts to install the anchor bracket to the underside of the base plate as in fig. 12.

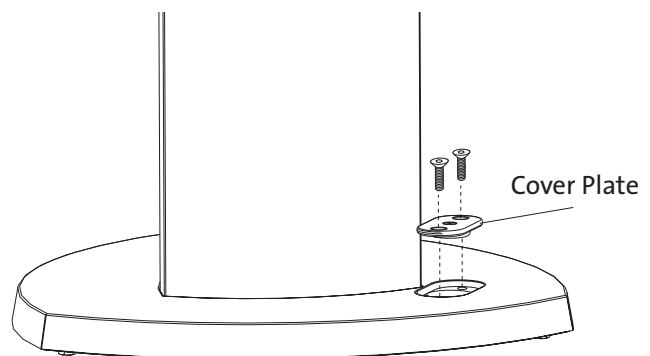

Figure 11. Remove cover plate from the pedestal base.

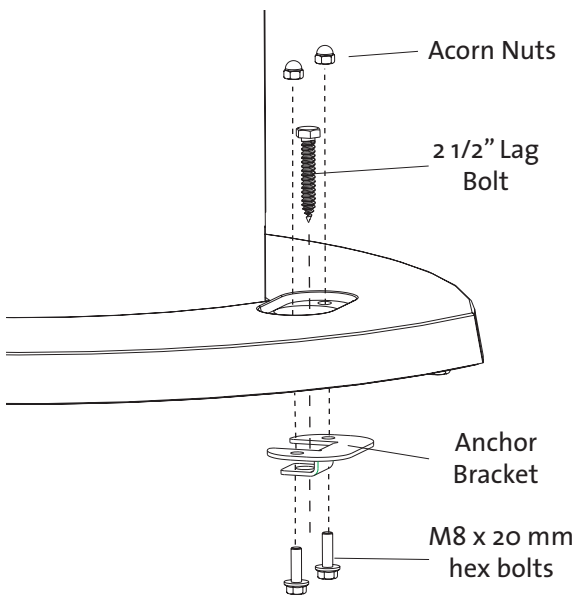

Figure 12.  
Attach the anchor bracket to the pedestal base.

## 5.4 Attach the Firebox to the Pedestal

1. Spread the shipping carton out to protect the floor and carefully lay the firebox on its side.
2. Use a 13 mm wrench to remove the four, M8 x 25 mm bolts from the bottom of the firebox as shown in fig. 13.
3. With assistance, attach the Pedestal to the Firebox as shown in fig. 14 using the four M8 x 25 mm bolts previously removed. Tighten securely.
4. Raise the stove into an upright position and place the serialized Safety Label directly under the firebox on the pedestal top plate so that it is accessible from the front of the stove.

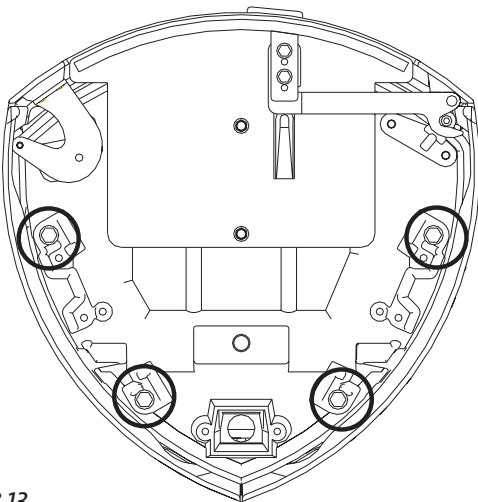

Figure 13.  
Remove four bolts from the firebox bottom.

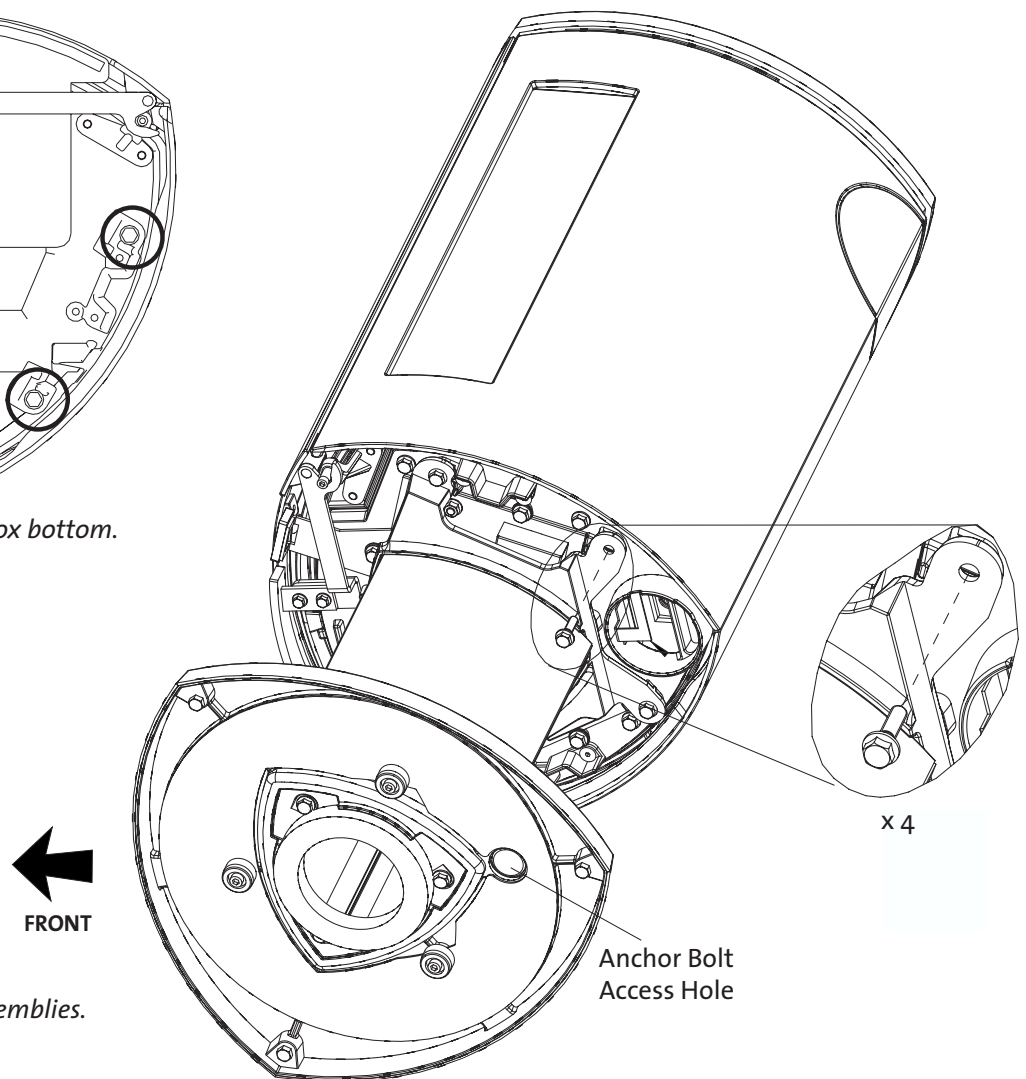

Figure 14.  
Join the Pedestal and Firebox assemblies.

## 5.5 Position the Stove

1. Use the clearance diagrams and associated flue collar connection center-line dimensions to determine the stove location appropriate to the clearance requirements specific to your installation. See fig, 8 Measure carefully and position the stove flue collar at the center-line convergence.

Double-check flue collar alignment with chimney connections at the wall thimble or chimney ceiling support adaptor.

## 5.6 Chimney Connector Installation

### 5.6.1 Top-exit Orientation

1. Replace the Top Plate.
2. Attach the crimped end of the first section of chimney connector to the Flue Outlet Adapter with sheet metal screws. Push the Outlet Adaptor fully into the flue collar. Fig. 16.
3. From inside the firebox, engage the locking rod through the tabs on the adaptor and secure it with the cotter pin.
4. Slide the Air Outlet Grille over the stove pipe into position on the Top Plate.
5. Re-check stove clearances to combustible materials and adjust the stove position as necessary.
6. Check stove level and plumb and adjust the leveling pads as appropriate.

### 5.6.2 Rear-exit Orientation

1. From inside the firebox, remove the rear Outlet Cover Plate with removal of the two M8 x 20 mm bolts. Fig. 17.
2. Remove the Flue Collar from the top plate and re-install it in the rear outlet position inside the firebox. Fig. 17.
3. Attach the crimped end of the first section of chimney connector to the Flue Outlet Adapter with four sheet metal screws. Push the Flue Outlet Adapter into the flue collar from outside the stove. From inside the stove, insert the bent end of the locking rod through one of the tabs, then slide the other end into the opposite tab. Secure the rod with the cotter pin.
4. Re-install the Flue Outlet Cover Plate over the top outlet inside the firebox.
5. Replace the Top Plate, Air Outlet Grille, and decorative Flue Outlet Cover Plate.

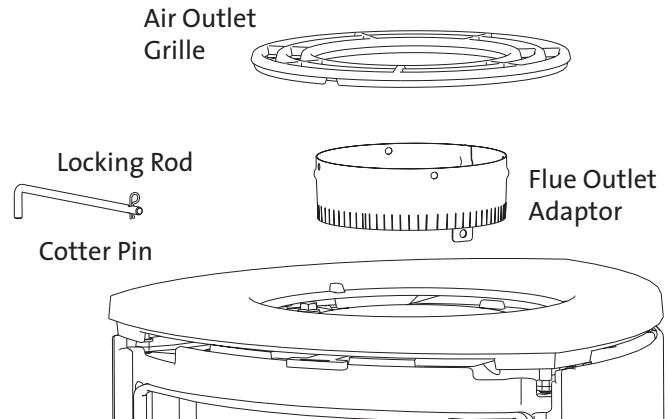

Figure 16. Installing the Outlet Adaptor and Flue Collar Grille.

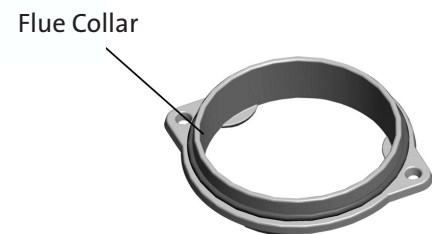
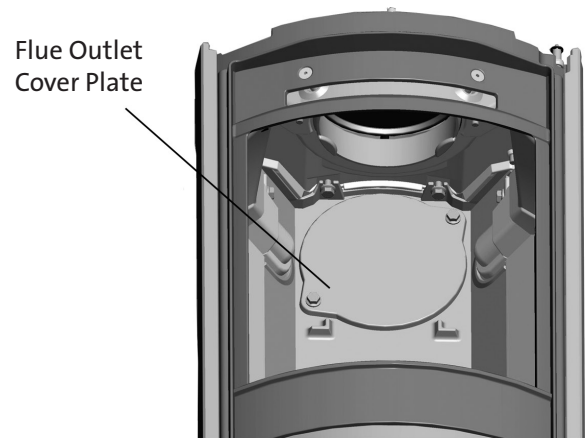

Figure 17. Outlet Cover Plate and Flue Collar.

## 5.7 Secure the stove to the hearth

1. At the anchor bracket hole, drill a 1/4" dia. pilot hole through the hearth and into the floor material.

NOTE: For masonry floor materials, install a 3/8" dia. lead bolt anchor or shield into the floor.

2. Open the pilot hole in the hearth material to 3/8" diameter to avoid cracking.
3. Secure the pedestal base to the hearth using the supplied 2 1/2" lag bolt and 9/16" socket wrench.
3. Replace the anchor cover plate and secure it with the two acorn nuts supplied with the anchor bracket.

## 5.8 Final Assembly

1. Replace the Ash Pan within the ash pan compartment.
2. Replace the Bottom Plate and Shaker Grate in the stove bottom.
3. Replace the Rear and Side skamol panels.
4. Place the two cast iron Burn Plates into position under the side windows. Fig. 18, A.
5. Replace the Smoke Baffle/Manifold in position in the upper firebox. It rests upon the side and rear skamol panels.

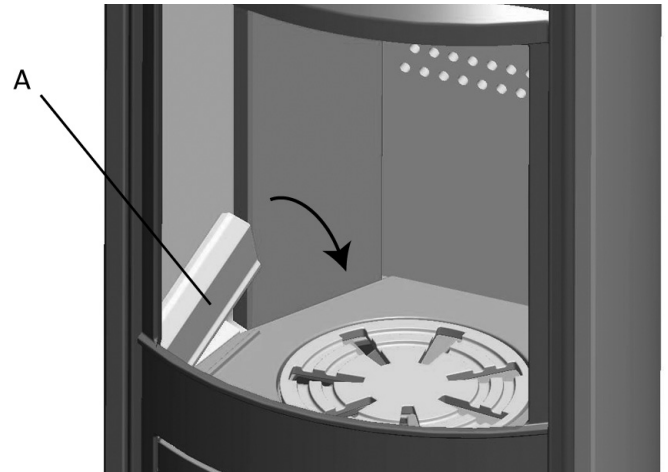

Figure 18. Install the cast iron burn plates.

## 6. Operation

Read the following section carefully before building a fire in your stove.

### 6.1 Fuel

This stove is designed to burn natural wood and biofuels ONLY. Wood that has been air-dried for a period of 6 to 14 months will provide the cleanest, most efficient heat. Hardwoods are preferable to softwoods. **Frequent use of green or inadequately seasoned wood is conducive to creosote accumulation and generally poor performance.**

#### DO NOT BURN...

- Coal
- Treated or painted wood
- Garbage
- Chemical Chimney cleaners
- Cardboard
- Colored paper
- Solvents
- Any synthetic fuel or logs

The burning of any of these materials can result in the release of toxic fumes. **NEVER USE GASOLINE, GASOLINE-TYPE LANTERN FUEL, KEROSENE, CHARCOAL LIGHTER FLUID, OR SIMILAR LIQUIDS TO START OR "FRESHEN-UP" THE FIRE.** Always keep such liquids away from the heater at all times.

#### **WARNING!**

**NEVER ALLOW THE FIRE TO REST DIRECTLY ON THE GLASS. THE LOGS SHOULD ALWAYS BE SPACED AT LEAST ONE INCH FROM THE GLASS TO ALLOW FOR PROPER AIR FLOW WITHIN THE STOVE.**

**OPERATE THIS STOVE ONLY WITH THE DOOR FULLY CLOSED. OPERATION WITH A PARTIALLY OPENED DOOR MAY RESULT IN OVER-FIRING. ALSO, IF THE DOOR IS LEFT PARTLY OPEN, GAS AND FLAME MAY BE DRAWN OUT OF THE STOVE OPENING, CREATING RISKS FROM BOTH FIRE AND SMOKE.**

#### **WARNING!**

**NEVER OVER-FIRE THE STOVE. IF ANY PART OF THE STOVE OR CHIMNEY GLOWS, YOU ARE OVER-FIRING. A HOUSE FIRE OR SERIOUS DAMAGE TO THE STOVE OR CHIMNEY COULD RESULT. IF THIS CONDITION OCCURS, IMMEDIATELY CLOSE THE AIR CONTROL.**

### 6.2 Air Control Settings

A single lever regulates the Primary Air flow that controls the intensity of the fire and consequent heat output and burn time. The lever is located within the slot above the stove door.

Primary Air enters the stove above the door and washes over the glass before reaching the fuel. A second source of primary air reaches the fire through the small pilot tube at the front of the firebox. Unrestricted secondary air is delivered through manifolds at the rear and top baffle where it ignites volatile gases that would otherwise pass unburned into the environment. See fig. 19. In this way, the wood is burned efficiently and exhaust is minimized. When the fire is burning well, little or no smoke will be evident from the chimney.

When first starting or reviving the fire, the control lever should be set at the far right position to allow the maximum amount of air into the stove. See fig. 19a. After the fire is well-established, the lever should be set at position to moderate incoming air to maintain the desired long term heat output and/or burn time.

In general, the more air made available to the fuel will result in the hottest fire intensity and the fastest fuel consumption. Alternatively, the less air made available to the firebox will result in low heat output and slower fuel consumption.

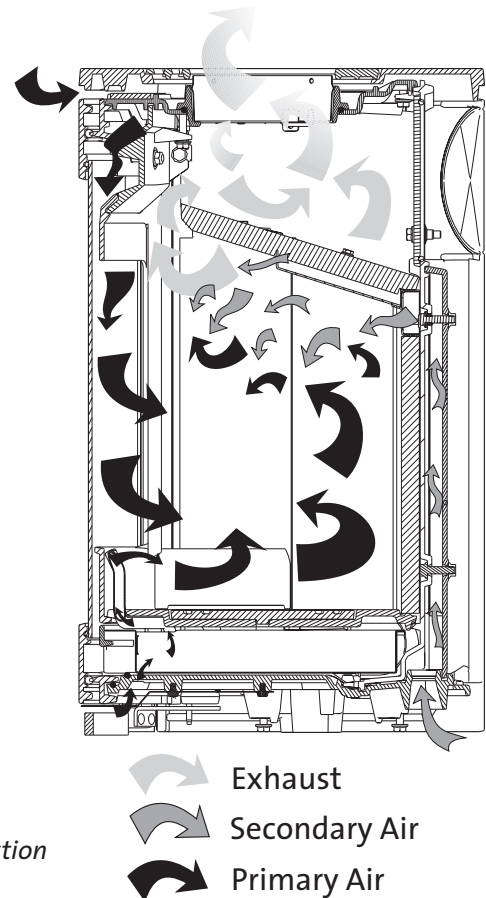

Figure 19.  
F 370 Combustion  
Air Flow

Use the following guide for best performance.

Burn Rate	Air Control Setting
Low	Fully Closed
Med. Low	3/32" Open
Med. High	7/16" Open
High	Max. Open

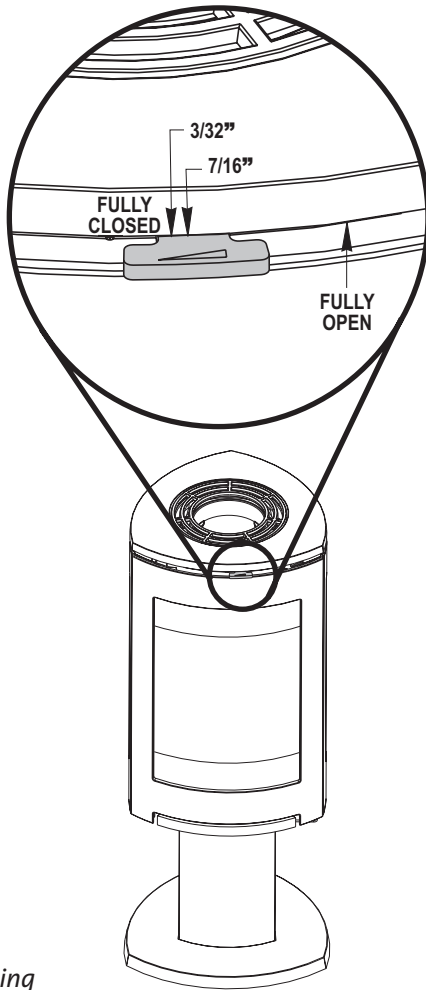

Figure 19a.  
Air Control Setting

### 6.3 Starting and Maintaining a Fire

**Burn only solid wood directly on the bottom plate of the stove. Do not elevate the fire in any way.**

1. Set the Air Control Lever in the full open position, all the way to the right. Crumple several sheets of newspaper directly on the bottom plate.
2. Place several pieces of small dry kindling (approx. 1" in diameter) on top of the newspaper, with two to three small split logs (approx. 2" to 3" in dia.) on top.
3. Light the fire and close the door. Gradually build the fire by adding larger and larger logs as the fire develops a bed of coals.
4. When you have added the final logs, adjust the Air Control Lever to provide the desired fire intensity.

Experiment with a variety of air control settings to determine the best one for your individual circumstances. Remember that fuel characteristics, chimney system condition, building design, and weather conditions all affect the performance of your stove. In time, you will discover how these elements combine and how you can work with them to achieve satisfactory performance.

### 6.4 Break-in Period

The cast iron parts of your stove require a break-in process to allow them to gradually adjust to thermal expansion and contraction. This is accomplished by building a series of three or four fires, each somewhat hotter than the last. Use a stove-top thermometer to monitor fire intensity and top plate temperature.

Adjust the Air Control lever to the Fully Open position. Limit the first fire to only kindling and a couple of 1-2 inch logs, keeping the temperature under 300°F. Allow the fire to burn out and return the stove to room temperature before building another fire.

Build progressively larger fires, maintaining intensity in +100°F increments, and allowing the stove to cool after each one. Keep the Air Control set to the fully open position.

**It is normal for a new stove to emit odor and possibly smoke during the first few fires. This is characteristic of the burn-off of residues from the manufacturing process and the curing of painted surfaces. Open a window near the stove to provide plenty of fresh air to the room during this "seasoning" period.**

## 6.5 Adding Fuel to the Fire

When reloading the stove while a bed of hot embers still exists, follow this reloading procedure:

- Always wear stove gloves when tending to the fire.
- **Before you open the door**, push the Air Control Lever to the full open position (far right).
- **Always wait a few seconds before opening the door.** This allows the renewed air circulation to clear unburned gases from the firebox. Hold the door open just slightly for a couple of seconds before opening it fully. This will also help ensure that no smoke escapes into the room.
- Use a stove tool or poker to distribute the hot embers equally around the firebox and push ashes into the ash pan.
- Load the fuel, usually with smaller logs first.
- Close the door and secure the latch.
- Wait 5 – 10 minutes for the fire to reestablish itself before adjusting the Air Control Lever for the desired heat output. If a thick bed of live coals is present, you may be able to add fuel and immediately set the air control without waiting for the fire to be reestablished.

## 6.6 Creosote Formation and the Need for Removal

This appliance is designed to burn wood cleanly and efficiently when operated as described in this manual. However, when wood is burned slowly and at low temperatures, tar and other organic vapors are produced which condense on the relatively cooler chimney flue surfaces to form creosote. Failure to keep the chimney system free of creosote build up could result in a chimney fire.

Creosote that accumulates in the chimney is highly flammable and is the fuel of chimney fires. To prevent a chimney fire, it is important to have the chimney flue and connector pipe cleaned and inspected at the beginning of each heating season, and subsequently inspected twice per month during frequent use. Clean the chimney whenever creosote accumulation of 1/4" or more is evident. A qualified chimney sweep or other authorized service person can provide this service.

It is also important to remember that chimney size, temperature and height all affect draft which in turn affects the formation of creosote. An exterior chimney, whether masonry or prefabricated steel, will be exposed to cold outside temperatures, and consequently, will be more prone to creosote accumulation than an interior flue.

A chimney flue located within the home interior will benefit from the insulating characteristics of the building itself. Consequently, the flue system will be less conducive to condensation of unburned gases and minimal creosote accumulation will result.

As a general rule, try to avoid burning the stove at the lowest air control settings. Although a low setting will prolong burn time, it may also result in incomplete combustion. In reducing the fire intensity, draft is weakened and the chimney flue cools. This, together with the increase in unburned gases, can lead to rapid creosote accumulation.

In the event that creosote ignites in the flue, the resulting fire is often accompanied by a roaring noise and crackling sound as flakes of burning creosote break loose. If you suspect you are having a chimney fire, immediately close the air controls and make sure the door is closed securely. Call the fire department and have everyone leave the house.

Do not attempt to extinguish the fire. Opening the door will only supply additional oxygen and intensify the fire. When the fire in the flue has subsided, resist the temptation to open the door to check on the fire. The fire may have suffocated, but could re-ignite with a supply of fresh air. After a chimney fire, do not use the stove until the chimney connector and flue have been cleaned and inspected to ensure no damage has been sustained.

See Section 7.2 of this manual regarding chimney cleaning.

---

## 7. Maintenance

### 7.1 Ash Removal

Ash removal will be required periodically depending upon how frequently the stove is used. Always wear stove gloves when handling ashes. Use a steel ash shovel or poker to push ashes through the bottom grate into the ash pan. This will minimize dust in the living area. Carry the ash pan outdoors and empty into a steel container with a tight-fitting lid. **NEVER USE A PAPER OR PLASTIC BAG AS AN ASH RECEPTACLE.**

The container of ashes should be placed on a noncombustible floor or on the ground, well away from all combustible materials, pending final disposal. If the ashes are disposed of by burial in soil or otherwise dispersed, **they should be kept in the closed container until all coals and cinders have thoroughly cooled.**

### 7.2 Chimney System Inspection and Cleaning

The Jøtul F 50 TL is designed to burn cleanly and efficiently when used according to the guidelines in this manual. In order to maintain proper performance, you should inspect the chimney and chimney connector at the beginning of each heating season and then twice per month during the heating season. Clean the chimney whenever creosote and fly ash accumulation exceeds 1/4 inch in any part of the system.

Chimney brushes are available from your local Jøtul dealer or hardware supply store. Your dealer can also refer you to a reputable, professional chimney sweep who will have all the equipment to ensure a complete and proper job.

**WARNING: FAILURE TO KEEP THE CHIMNEY CONNECTOR AND FLUE FREE OF CREOSOTE BUILD-UP CAN RESULT IN A CHIMNEY FIRE.**

### 7.3 Glass Care

#### 7.3.1 Cleaning

While the air wash design will help keep the glass clean, it is normal for some soot to accumulate on the glass surface during low burn periods. This will clear off during the next hot fire. Occasionally it will be necessary to clean the carbon deposits and fly ash off of the glass. If deposits are allowed to remain on the glass for an extended period of time, the glass may become etched and cloudy.

1. The glass must be COMPLETELY COOL.
2. Only use a cleaner that is specifically designed for this purpose. DO NOT USE ABRASIVE CLEANING AGENTS.

The use of abrasives will damage the glass, leaving a frosted surface. Crumpled newspaper is an especially good cleaning material.

3. Rinse and dry glass completely before lighting a fire.

#### 7.3.2 Glass Replacement

Always operate the door slowly and cautiously to avoid cracking or breaking the glass. Never use the door to push wood into the firebox. If the glass becomes cracked or broken follow the replacement procedure below.

#### IMPORTANT:

**NEVER OPERATE THE STOVE WITH A CRACKED OR BROKEN GLASS PANEL. Replace glass only with panels specifically designed for the Jøtul F 370. Do not use substitutes. Replacement glass can be ordered from your Jøtul dealer.**

Door Glass	221648
Side Glass, Outer	223210
Side Glass, Inner	223209

1. First loosen and then carefully remove the four glass clips from the inside of the door. See fig. 20.
2. Remove all pieces of the glass panel and gasketing.
3. Remove all remaining debris from the glass area using a wire brush.
4. Apply a small bead of gasket/stove cement and the new gasket. Do not overlap the ends of the gasket rope.
5. Center the new glass panel over the gasket and loosely reinstall the glass clips. Tighten the clips, alternating at opposite corners. Avoid applying uneven pressure on the glass.
6. It may be necessary to retighten the glass clips after the stove has burned and the gasketing has seated.

The procedure is the same for the side glass panels. Consult fig. 21 for glass clip and gasketing orientation.

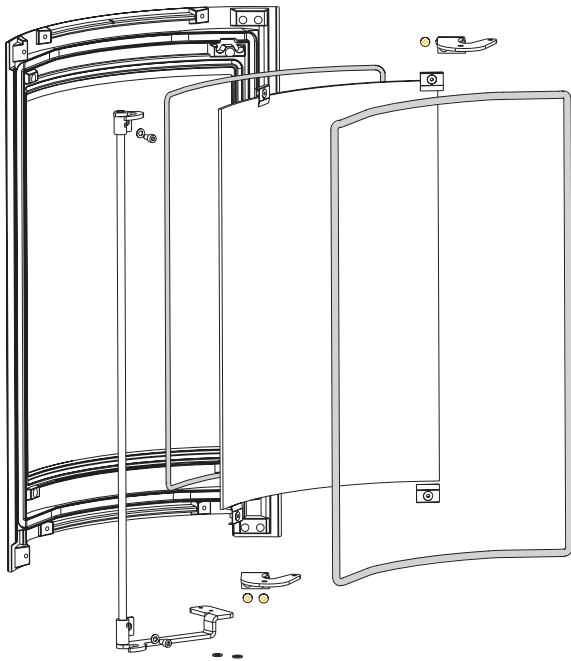

Figure 20. Glass and gasket replacement.

## 7.4 General Maintenance

Regular maintenance will assure proper performance and prolong the life of your stove. The following procedures do not take long and are generally inexpensive. When done consistently, they will help increase the life of your stove and assure satisfactory performance.

- Empty firebox of all soot and ashes. Never use a household vacuum cleaner to remove ashes. Only an ash vacuum with a metal container is acceptable and only when you are certain the ashes are completely cold.
- Inspect the firebox using a utility light inside and out for cracks or leaks. Replace cracked or broken skamol burn plates. These are wear parts and may require replacement from time to time.
 

Left and Right Burn Plates	223393
Rear Burn Plate	221805
Top Baffle	223292
- Clean the exterior cast iron surfaces with a soft, damp cloth. Use Jøtul High-temperature Satin Black paint to keep your stove looking new.

## 7.5 Gaskets

Check door and glass gaskets for seal integrity. The gaskets should be soft enough to be somewhat resilient to the touch. Over time, gaskets will compress and harden. Replace worn-out or hardened gaskets with the appropriate size material available from your local Authorized Jøtul Dealer.

To check the seal of the front door, close and latch the door on a dollar bill and slowly try to pull the dollar bill free. The seal is too loose if the bill can be easily removed. Adjust the door latch and test again.

### 7.5.1 Gasket Replacement

See the chart below for replacement gasket specifications.

1. Remove the old gasket material with a pliers and thoroughly clean the channel with a wire brush.
2. Lay out the new gasket around the channel to determine length. Trim the gasket to leave 1" excess.
3. Apply a small bead of gasket or furnace cement in the channel.
4. Lightly press the new gasket into the channel, being careful to avoid compressing or stretching it. Trim the gasket further as necessary to allow the tail end to slightly overlap the other end.
5. Wait ten minutes to allow the cement to set and then close and latch the doors. Reopen the doors and use a damp cloth to wipe away any excess cement that may be squeezed out from under the gasket.

### Replacement Gaskets

Door & Door Glass Gasket Kit	157050
Door Glass Gasket	
LD .250-2 Ø6 Fiberglass Rope 80"	200024
Door Gasket	
LD .375-2 Ø9 Fiberglass Rope 96"	129296
Side Glass Gasket, inner & outer	
LD .250-2 Ø6 Fiberglass Rope 80"	200024
Flue Outlet Cover Plate & Flue Collar Gasket	
LD .250-2 Ø6 Fiberglass Rope 24"	200024

# 8. Jøtul F 370 Illustrated Parts Diagram

Use only genuine Jøtul replacement parts.  
 Do not substitute parts from any other  
 manufacturer. See your local Authorized  
 Jøtul Dealer or contact us directly:  
 Jøtul North America  
 55 Hutcherson Dr.  
 Gorham, Maine 04038

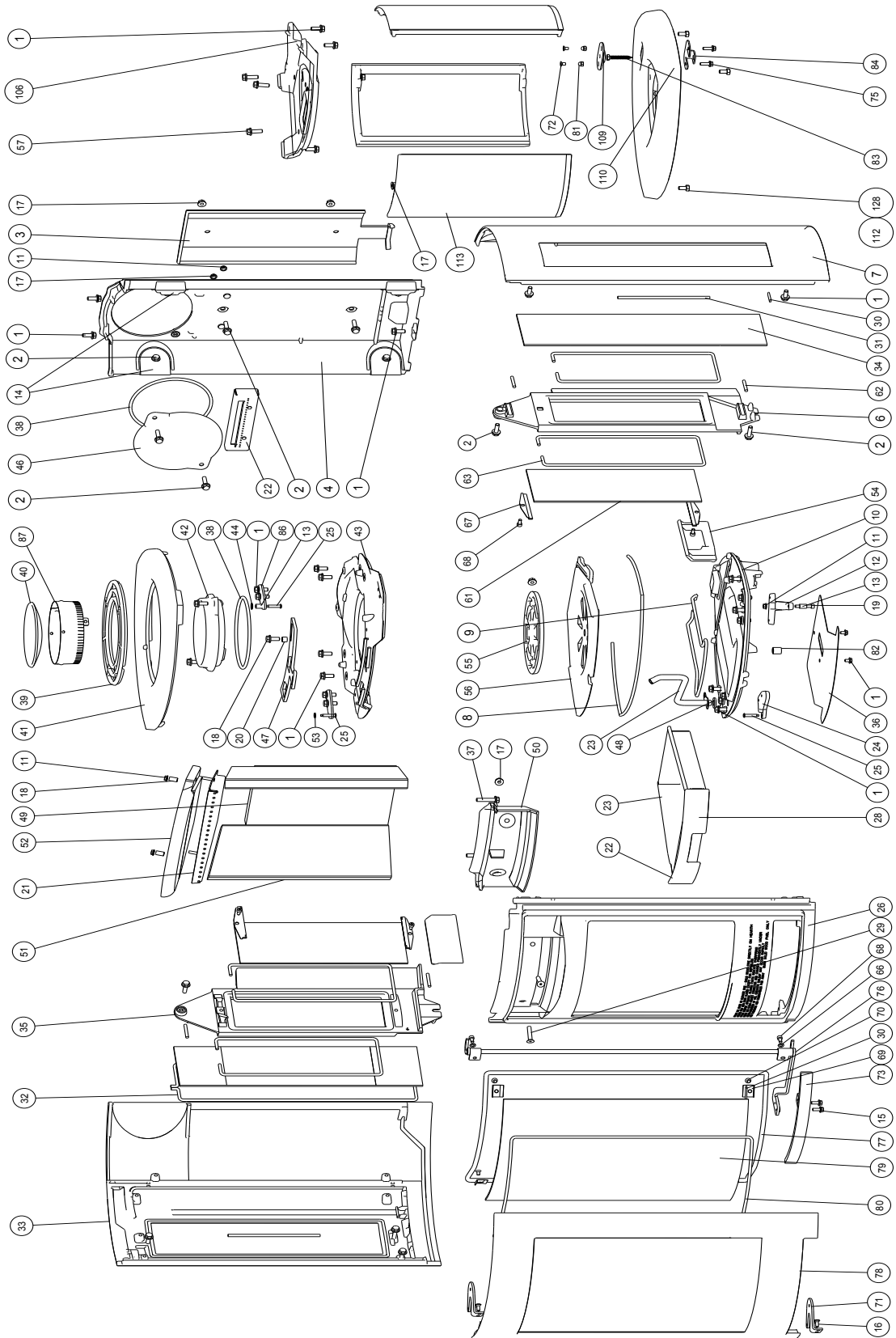

Figure 21.

## 8.1 Jøtul F 370 Parts List

No.	Description	Part Number
1.	Screw, Hex Cap, M8 x 20	117875
2.	Screw, Hex Cap, M8 x 30	117877
3.	Air Manifold, Rear	10448312
4.	Rear Plate	10446718
6.	Glass Holder, Right - inc. 5(1),30,62,63,67,68 (2 pcs.ea.)	156844
7.	Side Plate, Right - BP	10446592
8.	Gasket, Bottom Plate - LD 250-2 Ø6,4 x 930mm	200024
9.	Gasket, Ash Pan Rider - LD 250-2 Ø6,4 x 785mm	200024
10.	Bottom Plate	157147
11.	Nut, Flange Hd Hex - M6	117968
12.	Lock Lower Door	10447318
13.	Sleeve, 2 x 15 mm	126109
14.	Cover, Side Bolt	10460212
15.	Screw, Hex Cap Flange - M6 x 16	99625
16.	Screw, Phillips - M6 x 12mm	117976
17.	Nut, Hex Cap Flange Hd, M8	117881
18.	Sleeve, 10 x 8.2 x 10 mm Steel	223324
19.	Screw, Socket Hd Cap, M6 x 35	117789
21.	Secondary Air Manifold Assembly, Top	222786
22.	Secondary Air Manifold, Rear	222787
23.	Primary Air Tube	222797
24.	Door Hinge, Lower	10447292
26.	Front Plate, BP	10446692
28.	Ash Pan, Complete Assembly	157180
29.	Screw, Countersunk Internal Hex, M8 x 40	116913
30.	Gasket, V-125 x 40mm	127215
31.	Gasket, Side Glass - Outer, toward Front	200024
32.	Gasket, Side Glass - Outer, toward Side	200024
33.	Side Plate, Left - BP	10446492
34.	Glass, Side Outer -Rt & Lt	222157
35.	Glass Holder, Left - inc. 5(1),30,62,63,67,68 (2 pcs.ea.)	156845
36.	Handle Shield	223294
37.	Screw, Hex Cap Flange M8 x 40	117879
38.	Gasket, LD 250-2 Ø6 -4 x 600mm	200024
39.	Air Outlet, Top - BP	10441692
40.	Top Outlet Filler - BP	10441792
41.	Top Plate, Upper - BP	10447092
42.	Smoke Outlet, Ø150 mm	156240
43.	Top Plate, Lower	10433818
44.	Push Nut, Ø6 x Ø15 mm Blk	117859

No.	Description	Part Number
46.	Smoke Outlet Cover Plate	10441112
47.	Air Valve - BP	22329892
48.	Gasket, Air Tube - Manninglass	223310
49.	Burn Plate, Rear - Skamol	223293
50.	Air Manifold, Front	10433912
51.	Burn Plate, L & R Side - Skamol	221805
52.	Baffle	223292
53.	Washer, Ø6.2 x 12 x 1.8 Brass	128632
54.	Burn Plate, Lower - L & R, cast iron	10447512
55.	Grate	10434912
56.	Bottom Plate, Inner	10434812
57.	Screw, Hex Cap Flange, M8 x 25mm	117876
59.	Screw, Hex Cap Flange, M6 x 10mm	9962
60.	Screw, Countersunk Cap Internal Hex - M8 x 16mm	117739
61.	Glass, Side - Inner, L & R	221867
62.	Gasket, Glass Holder LD 250-2 Ø6,4 x 40mm	200024
63.	Gasket, Glass Holder LD 250-2 Ø6,4 x 1000mm	200024
66.	Washer, Ø6 x Ø12 x 0.5mm	117588
67.	Glass Clip, Side Inner Glass - inc. gasket	153620
68.	Screw, Cylinder Head Internal Hex - M6 x 12mm	118231
69.	Glass Clip, Door Glass	128412
70.	Screw, Countersunk Cap Internal Hex - M6 x 10mm	117977
71.	Door Hinge - UP	22166218
73.	Door Handle	223309
75.	Bolt, Serrated Flange Hex Hd, M6 x 20mm Blk	117117
76.	Door Latch Assembly	221659
77.	Gasket, Door to Front Plate - LD 375-2 Ø9, 5 x 2100mm	100038
78.	Door, BP	10446392
79.	Door Glass, Ceramic	221648
80.	Gasket, Door Glass - LD 250-2 Ø6,4 x 2000mm	200024
81.	Acorn Nut, 2	118253
82.	Door Handle Bumper	221897
83.	Bolt, Lag 3/8" x 2.5", 1	118252
84.	Bracket, Anchor, 1	224499
85.	Upper Hinge Assembly	157186
86.	Upper Door Catch Assembly	157187
87.	Vent Adaptor	222793
106.	Pedestal Top	10448712
109.	Brake Cover - BP	10453692
110.	Pedestal Bottom - BP	10449192
112.	Screw, Hex Cap - M8 x 16	9912
113.	Pedestal Side - BP	10448892

Only use replacement parts provided through your authorized Jøtul dealer.

# 9. Jøtul Wood-burning Product Limited Warranty

Effective February 1, 2010

This warranty policy applies to wood-burning products identified by Jøtul and Scan trade names, as set forth below.

## A. Cast Iron, Enamel, and Steel Components:

Jøtul North America Inc. (JØTUL) warrants, to the original retail purchaser, that those components of the Jøtul or Scan Stove or Fireplace specified above will be free of defects in material and workmanship for a period of five (5) years from the date of purchase. This warranty is subject to the terms, exclusions and limitations set forth in the following text.

## B. Electrical Components (blowers, thermostatic switches):

JØTUL warrants, to the original retail purchaser, that those components of the Jøtul or Scan Stove or Fireplace specified above will be free of defects in material and workmanship for a period of one (1) year from the date of purchase. This warranty is subject to the terms, exclusions, and limitations set forth in the following text:

JØTUL will repair or replace (including parts & labor), at its option, any of the above components determined by JØTUL to be covered by this warranty. You must, at your own expense, arrange to deliver or ship the component to an authorized Jøtul or Scan dealer and arrange for pickup or delivery of the component after repairs have been made. If, upon inspection, JØTUL determines that the component is covered by this warranty, the repair or replacement will be made as set forth above. This warranty is not transferable and is extended only to, and is solely for the benefit of, the original retail purchaser of the Jøtul or Scan Stove or Fireplace. This paragraph sets forth the sole remedy available under this warranty in the event of any defect in the Jøtul or Scan Stove or Fireplace.

The warranty period for any replaced component will be the remaining unexpired portion of the warranty period for the original component.

Please retain your dated sales receipt in your records as proof of purchase.

## Exclusions and limitations

**Notice:** This warranty is void if installation or service is performed by someone other than an authorized installer or service agency, or if installation is not in conformance with the installation and operating instructions contained in this owner's manual or local and/or national fire and building regulations. A listing of local authorized installers, service agencies and gas suppliers can be obtained from the National Fireplace Institute at <http://www.nficertified.org/>.

## This warranty does not cover the following:

1. Repair or replacement of parts that are subject to normal wear and tear during the warranty period or to parts that may require replacement in connection with normal maintenance. These parts include paint, gaskets, burn plates, baffles, air manifolds, firebricks, fire grates, or glass (glass is only warranted against thermal breakage).
2. Damage due to incorrect installations not in conformance with the installation instructions contained in this owner's manual or local and/or national fire and building regulations.
3. Damage, including damage to enamel surfaces, caused by improper operation, over-firing, and/or misuse. Improper operation, such as burning the stove with the ash door open, can damage the stove. Over-firing occurs when any part of the stove glows red. Over-firing can also be identified by warped plates, rust-colored cast iron, paint pigment that has turned dusty white, or bubbling, cracking and discoloration of the enamel finish. Misuse includes, without limitation, use that is not in conformance with the operating instructions contained in this owner's manual.
4. Damage due to service performed by an installer or service agency, unless otherwise agreed to in writing by JØTUL.
5. Damage caused by unauthorized modification, use or repair.
6. Costs incurred by travel time and/or loss of service.
7. Labor or other costs associated with the repair of components beyond the warranty period.
8. Damage incurred while the Jøtul or Scan Stove or Fireplace is in transit.

**IN NO EVENT SHALL JØTUL, ITS PARENT COMPANY, SHAREHOLDERS, AFFILIATES, OFFICERS, EMPLOYEES, AGENTS OR REPRESENTATIVES BE LIABLE OR RESPONSIBLE TO YOU FOR ANY SPECIAL, INDIRECT, INCIDENTAL, CONSEQUENTIAL, PUNITIVE OR OTHER SIMILAR DAMAGES, INCLUDING, BUT NOT LIMITED TO, LOST PROFITS, LOST SALES, INJURY TO PERSON OR PROPERTY, OR DAMAGES TO A STRUCTURE OR ITS CONTENTS, ARISING UNDER ANY THEORY OF LAW WHATSOEVER. ALL IMPLIED WARRANTIES, INCLUDING THE IMPLIED WARRANTIES OF MERCHANTABILITY AND FITNESS FOR A PARTICULAR PURPOSE, OR OTHERWISE, ARE LIMITED IN DURATION TO THE LENGTH OF THIS WRITTEN WARRANTY. EXCEPT AS EXPRESSLY SET FORTH HEREIN, JØTUL MAKES NO ORAL, WRITTEN OR OTHER WARRANTY WITH RESPECT TO JØTUL OR SCAN STOVES OR FIREPLACES.**

Some states do not allow the exclusion or limitation of incidental or consequential damages, or limitations on the length of implied warranties. Therefore, the above exclusions or limitations may not apply to you. This warranty gives you specific legal rights, and you may have other rights, which vary from state to state.

JØTUL reserves the right to discontinue, modify or change the materials used to produce the Jøtul or Scan Stove or Fireplace. JØTUL shall have the right to replace any defective component with substitute components determined by JØTUL to be of substantially equal quality and price.

The dollar value of JØTUL's liability for breach of this warranty shall be limited exclusively to the cost of furnishing a replacement component. JØTUL shall not in any event be liable for the cost of labor expended by others in connection with any defective component. Any costs or expenses beyond those expressly assumed by JØTUL under the terms of this warranty shall be the sole responsibility of the owner(s) of the Jøtul or Scan Stove or Fireplace.

No dealer, distributor, or other person is authorized to modify, augment, or extend this limited warranty on behalf of JØTUL. **NO MODIFICATION OR CHANGE TO THIS WARRANTY WILL BE EFFECTIVE UNLESS IT IS MADE IN A WRITTEN DOCUMENT MANUALLY SIGNED BY AN AUTHORIZED OFFICER OF JØTUL.**

An authorized installer may have been provided with certain information related particularly to the Jøtul or Scan Stove or Fireplace; however, no authorized installer or other person who may service the appliance is an agent of JØTUL. No inference should be made that JØTUL has tested, certified, or otherwise pronounced any person as qualified to install or service the appliance. JØTUL shall not be liable or otherwise responsible for any error or omission by a person installing or servicing a Jøtul or Scan Stove or Fireplace.

If you believe your Jøtul or Scan Stove or Fireplace is defective, you should contact your nearest authorized Jøtul or Scan dealer, who will process a warranty claim. **IN ORDER TO QUALIFY FOR WARRANTY COVERAGE, JØTUL MUST RECEIVE NOTICE OF A POSSIBLE DEFECT WITHIN SIXTY (60) DAYS OF THE DATE THE DEFECT IS FIRST DISCOVERED, OR REASONABLY COULD HAVE BEEN DISCOVERED.**

*This warranty is given by Jøtul North America, Inc.,*

*55 Hutcherson Drive, Gorham, Maine 04038 USA*

Cat. no. 10036803 (224353\_A)  
May 26, 2011

This appliance must be installed in conformance with local and national building regulations. It is important that these instructions be carefully read and understood before beginning the installation. Jøtul pursues a policy of continual product development. Consequently, products may differ in specification, color or type of accessories from those illustrated or described in various publications.

Jøtul vise sans cesse à améliorer ses produits. C'est pourquoi, il se réserve le droit de modifier les spécifications, couleurs et équipement sans avis préalable.



**Jøtul AS**  
P.O. Box 1411  
N-1602 Fredrikstad,  
Norway

**Jøtul North America, Inc.**  
55 Hutcherson Dr.  
Gorham, Maine 04038  
USA