

Installation, Operation and Maintenance Instructions

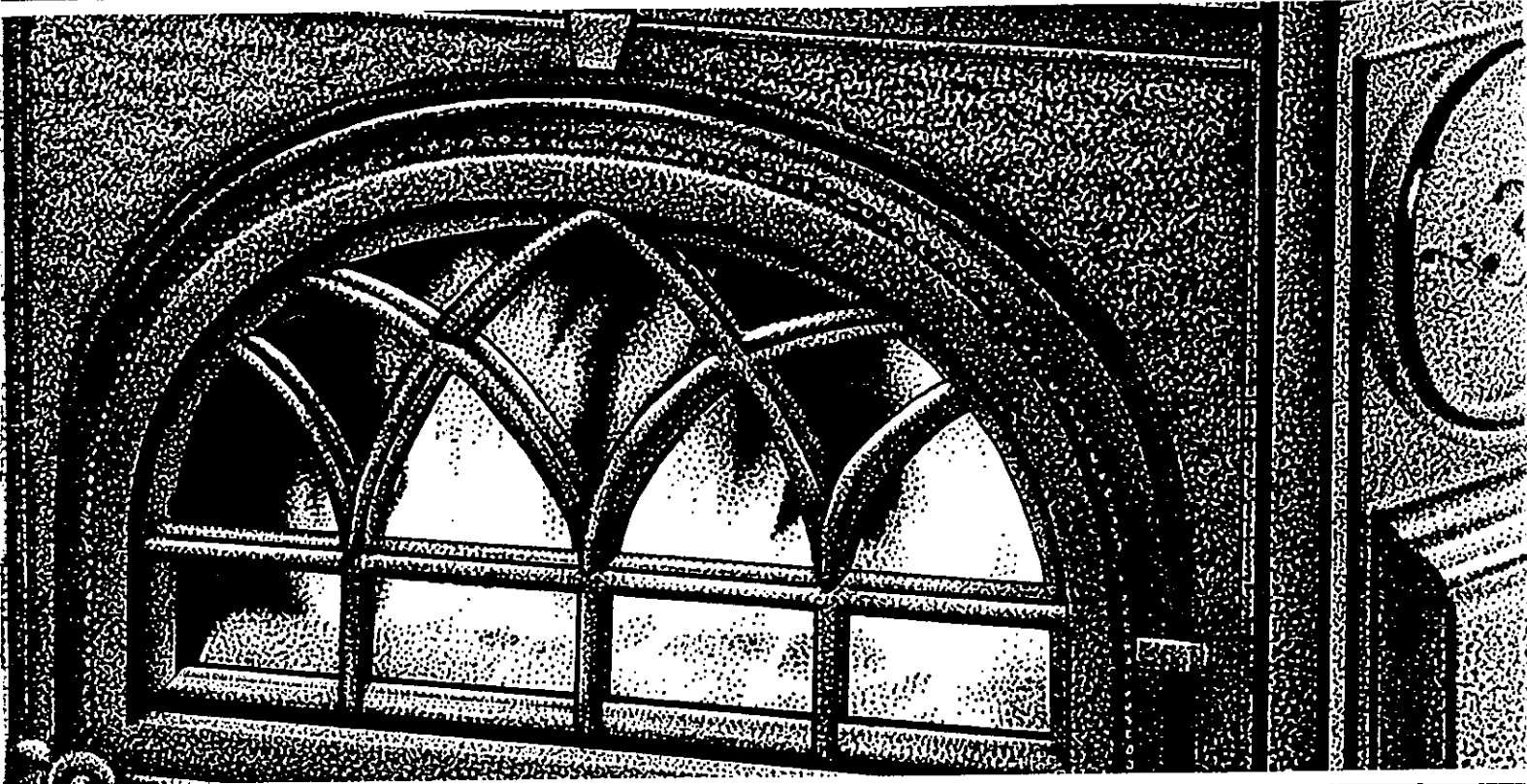

Jotul 3TD & 3TDC



Tested & Listed by: OMNI™, Beaverton, Oregon
Tested to UL 737, UL 1482. Test date, March 24, 1987. Report no. SS080-1.
I.C.B.O. No. TL 130

SAFETY NOTICE

IF THIS FIREPLACE STOVE IS NOT PROPERLY INSTALLED, A HOUSE FIRE MAY RESULT. FOR YOUR SAFETY, FOLLOW THE INSTALLATION DIRECTIONS. CONTACT LOCAL BUILDING OR FIRE OFFICIALS ABOUT RESTRICTIONS AND INSTALLATION INSPECTION REQUIREMENTS IN YOUR AREA.

Aksjeselskapet Jotul, Postboks 6206-ET. Oslo 6, Norway

40 1

40 1

40 15

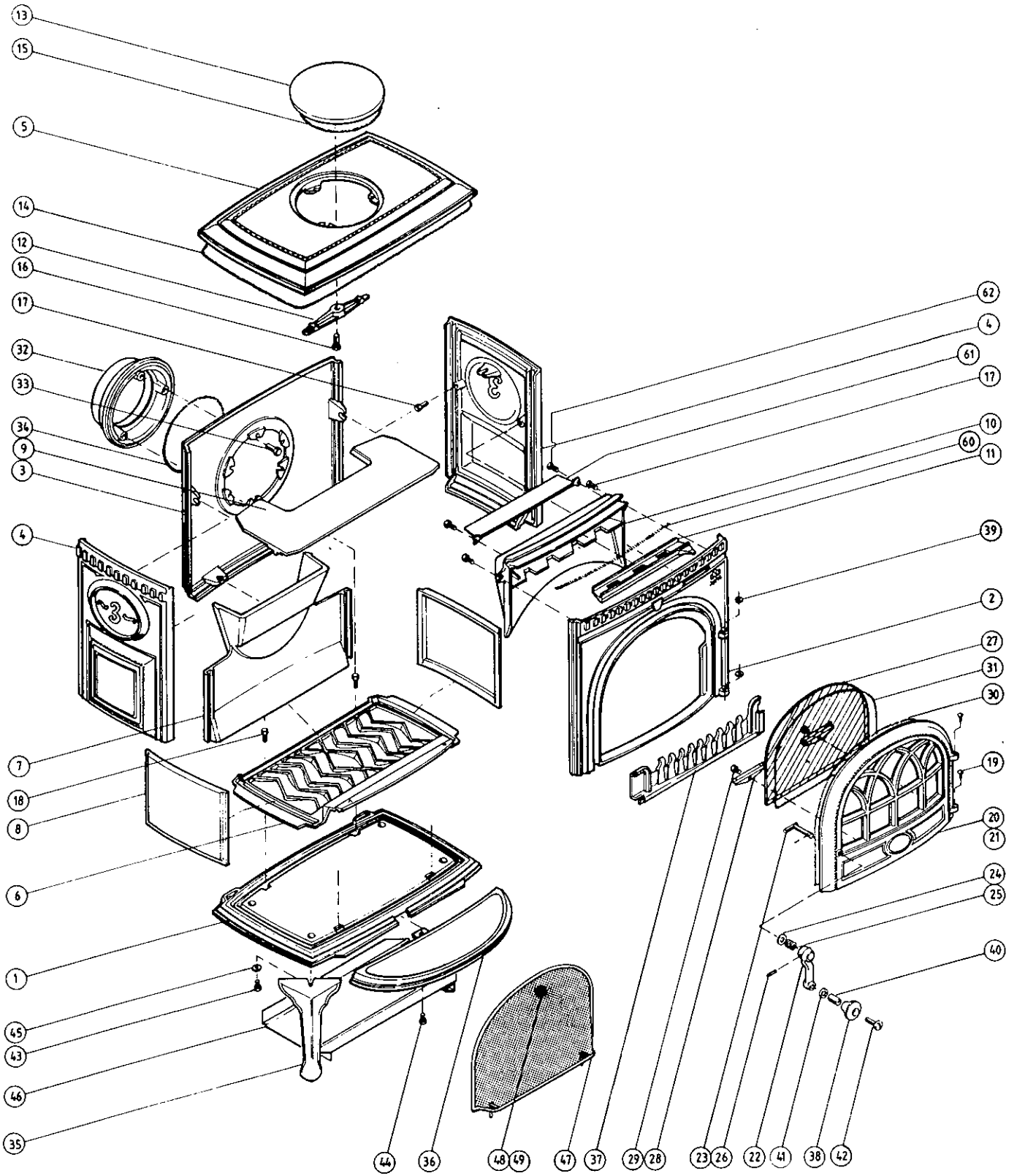

Parts List—Fireplace No. 3TD & 3TDC

Pos. No.	Description	Quantity
1	Bottom plate	1
2	Front plate	1
3	Back plate	1
4	Side plate	2
5	Top plate	1
6	Bottom burnplate	1
7	Back burnplate	1
8	Side burnplate	2
9	Baffle plate	1
10	Combustion air inlet chamber	1
11	Draft control valve	1
12	Traverse bar	1
13	Flue outlet cover plate	1
14	Gasket .010 x 1605 mm	1
15	Gasket .0226 x 10 x 2 mm	1
16	Screw hex.h M6 x 16	1
17	Screw hex.h M6 x 20	6
18	Screw hex.h M6 x 25	4
19	Pin	1
20	Door complete	1
21	Door	1
22	Door handle	1
23	Latch for door	1
24	Washer .025 x .010, 5	1
25	Spring	1
26	Split pin	1
27	Glass	1
28	Clips for glass	2
29	Screw pan pozidrive M6 x 8	2
30	Gasket .07 x 1410 mm	1
31	Gasket .04 x 1040 mm	1
32	Flue outlet	1
33	Screw hex.h M6 x 16	3
34	Gasket .0226 x 10 x 2 mm	1
35	Leg 215 mm	4
36	Ash lip	1
37	Ash retainer	1
38	Wooden knob	1
39	Washer .012 x .06 x 0, 5	2
40	Case	1
41	Washer klingelitt	1
42	Screw pan pozidrive M6 x 35	1
43	Screw hex.h M6 x 20	4
44	Screw hex.h M6 x 16	1
45	Washer .018 x .06, 4	4
46	Heat shield	1
47	Spark arrester, complete	1
48	Spring	1
49	Handle, bakelite	1
60	Gasket .04 x 400	1
61	Baffle for secondary air	1
62	Screw hex.h M6 x 16	2

Table of Contents

1. General Information.....	4
2. Hazards Connected to the use of the Jotul Fireplace Stove.....	4
3. Installation.....	5
Chimney Connector	5
Thimble.....	5
Masonry Thimble	5
Listed Prefabricated Thimbles.....	6
Chimneys	6
Masonry Chimneys.....	6
Connection to a Metal Prefabricated Chimney	7
Stove Placement.....	8
Floor Protection.....	8
Clearances.....	9
Reduced Clearances	9
Fireplace Venting & Clearances.....	10
Connection to a Masonry Fireplace	11
4. Assembly.....	11
Optional Equipment.....	12
5. Operation.....	12
Wood Storage	12
Creosote Removal.....	12
Breaking in your stove	13
Building a fire.....	13
Refueling	13
Disposal of ashes	13
6. Maintenance	13
7 Catalyst Operation.....	14
Addition Fuel.....	14
Inspection & Maintenance.....	14

1. General Information

Jotul has been making cast iron wood and coal stoves since 1853 and is the world's largest manufacturer of solid fuel burning appliances. Your new Jotul stove has inherited the benefits learned from over 125 years of producing stoves. With proper care and maintenance, your new Jotul stove should last for many, many years.

This owner's manual covers the Jotul American Fireplace Model 3TD and Model 3TDC. Model 3TDC is identical to Model 3TD except that model 3TDC contains a 7" flue outlet which houses a catalytic combustor. Model 3TD can be converted to Model 3TDC at any time by replacing its 6 inch diameter flue outlet with the Jotul catalyst (Part #5000). It should be noted that Model 3TDC requires a 7 inch diameter chimney connector, whereas Model 3TD requires a 6 inch chimney connector.

Model 3TDC was developed to meet air quality standards now in effect in various parts of the U.S. Model 3TDC employs catalytic technology similar to that used to reduce emissions from automobiles. The catalyst enables gas and smoke to burn at less than half the temperature it normally takes to burn them. The combustion of gases and smoke in the catalyst releases more energy and converts the gases to simple compounds.

In a normal hot fire, the gases and smoke driven off during combustion are burned without the aid of a catalyst. Even though a catalyst will enable smoke to burn at lower temperatures, a cool smoldering fire should be avoided. If operated properly, the Model 3TD will be nearly as efficient as the Model 3TDC.

When installing, operating, and maintaining your Jotul Fireplace Stove, follow the guide-lines given in these instructions. Save these instructions and keep them so that they are always available to anyone using the stove.

Several areas of the country require a building permit to install a solid fuel burning appliance. The National Fire Protection Association's Code 211 or similar regulations may apply to the installation of solid fuel burning appliances in your area. Your dealer has been specially selected for his knowledge of your local codes and can provide assistance in making sure your installation is safe and legal. Contact your insurance representative, or building or fire officials to determine what regulations apply in your area.

2. Hazards Connected to the use of the Jotul Fireplace Stove

Any use of fire in the house represents a certain danger and with intense overfiring, temperatures on the surface of the Jotul Fireplace Stove can exceed 1000°F (536°C)

Please comply with the following warnings.

- Never overfire the stove. If any part of it glows, you are overfiring, and serious damage to the stove or a chimney fire could result. Immediately close down the draft control if you notice this condition.
- Never modify the Jotul Fireplace Stove in any way which is not in accordance with the manufacturer's specifications.
- Teach children that the stove is hot and should not be touched.
- Never burn trash of any kind in the stove.
- Do not dry clothes over the stove; they could ignite.
- Keep loose flammable materials at least 48 inches away from the stove.
- Never use the stove if there are combustible gases in the house. A few examples of combustible gases are the fumes from certain cleaning fluids, adhesives, and paints.
- Always wear protective gloves when adding fuel to the fire.
- Use only seasoned wood in your Jotul Fireplace Stove. Never use synthetic logs or fireplace coal.
- Never use gasoline, gasoline-type lantern fuel, kerosene, charcoal lighter fluid, or similar liquids to start or "freshen up" a fire in this heater. Keep all such liquids far away from the heater while it is in use.
- Never operate the Jotul Fireplace Stove with cracked or broken glass. Replace damaged glass with ceramic glass 4mm in thickness (available from your dealer).
- Avoid creating a low pressure condition in the room where the stove is operating. Operating an exhaust fan or a clothes dryer could create a low pressure area, causing poisonous gases to come out of the stove into the room. You can prevent a low pressure condition by providing adequate outside combustion air within 24 inches of the stove.
- **This stove is not approved for use in mobile homes.**

3. Installation

SAFETY NOTICE

IF THIS STOVE IS NOT PROPERLY INSTALLED, A HOUSE FIRE MAY RESULT. FOR YOUR SAFETY, FOLLOW THE INSTALLATION DIRECTIONS. CONTACT LOCAL BUILDING OR FIRE OFFICIALS ABOUT RESTRICTIONS AND INSTALLATION INSPECTION REQUIREMENTS IN YOUR AREA.

PLEASE READ THIS ENTIRE MANUAL BEFORE YOU INSTALL AND USE YOUR NEW STOVE. FAILURE TO FOLLOW INSTRUCTIONS MAY RESULT IN PROPERTY DAMAGE, BODILY INJURY, OR EVEN DEATH.

A safe stove installation involves several elements. These elements are; (A) the chimney connector, (B) a thimble between the chimney connector and chimney, (C) the chimney itself, and (D) protection of combustible materials in the vicinity of the stove. Each of these elements are equally important for any safe stove installation.

CHIMNEY CONNECTOR

This is also known as stove pipe or flue pipe. It is used to connect the stove to the chimney. For Model 3TD, the chimney connector should be 6 inch diameter black steel, 24 gauge minimum. For Model 3TDC, the chimney connector should be 7 inch diameter black steel, 24 gauge minimum.

Do not use aluminum or galvanized steel. They cannot properly withstand the extreme temperatures of a wood fire. Do not use chimney connector pipe as a chimney.

Chimney connector sections must be attached to the stove and to each other with the crimped end toward the stove (Figure 1). This allows creosote to run into the stove and not onto the outside of the pipe. All joints should be secured with three sheet metal screws. Otherwise, in the event of a creosote fire, the connector may vibrate apart.

For proper operation the chimney connector should be as short as possible. Horizontal lengths of chimney connector should have an upward slope from the stove of 1/4 inch per foot.

Maintain 18 inches clearances between the chimney connector and the wall and ceiling unless a wall protection system is installed.

Figure 1

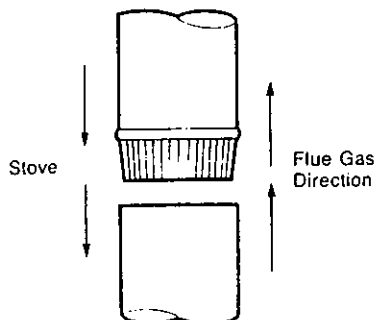

THIMBLE

This is a masonry or listed prefabricated device installed in combustible walls through which the chimney connector passes to the chimney. It is intended to keep walls from igniting.

A thimble must be used when the chimney connector (stove pipe) passes through a combustible wall to a masonry chimney.

MASONRY THIMBLE

Construction of a masonry thimble requires 12 inches of brick around a fire clay liner. Be sure to locate it so that the top of the chimney connector will be at least 18 inches below the ceiling. To construct the brick thimble for Model 3TD, you will need an opening of 30 inches by 30 inches. Model 3TDC requires an opening of 31 inches by 31 inches. It will be necessary to cut wall studs and install headers and a sill frame to maintain proper dimensions and to hold the weight of the brick (Figure 2).

Minimum 3-1/2 inch (4-inch nominal) thick solid bricks are to be used. The fire clay liner (ASTM C35 or equivalent), minimum 5/8-inch wall thickness, must not penetrate into the chimney beyond the inner surface of the chimney flue liner and must be firmly cemented in place. If it is necessary to cut a hole in the chimney liner, use extreme care to keep it from shattering. Refractory mortar must be used at the junction to the chimney liner. After the assembly is complete, insert the chimney connector in the fire clay liner. Do not push it beyond the inside edge of the chimney liner because this will affect the draw of the chimney (Figure 3).

Figure 2

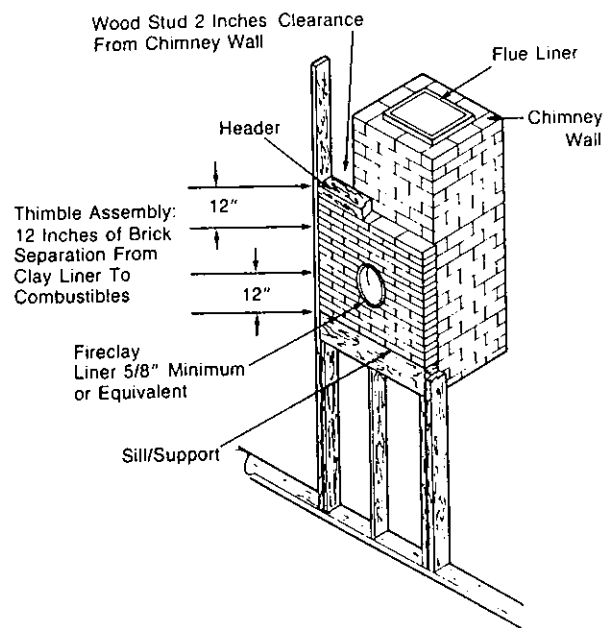

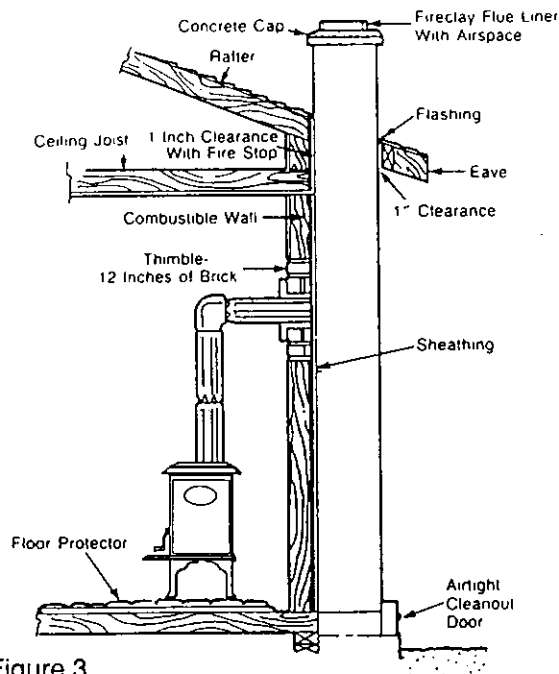
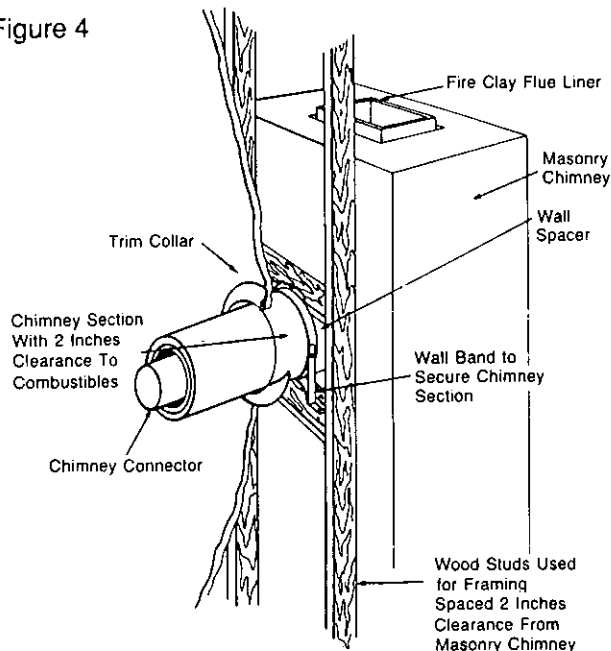

Figure 3

LISTED PREFABRICATED THIMBLES

Several manufacturers have developed safe alternatives to the brick thimble just described. In general, these are various types of insulated metal pipes with the necessary hardware to ensure proper clearances. These offer the advantages of being lighter than the brick thimble and requiring less room. These thimbles are "listed." "Listed" means that a laboratory independent of the manufacturer has tested them and certifies they are safe if installed according to the manufacturer's directions. Be sure if you select a prefabricated thimble system that it is listed for use with woodstoves. Figure 4 shows a typical installation using a section of insulated pipe for a thimble.

Figure 4



CHIMNEYS

There are two types of chimneys suitable for the Jotul fireplace stoves. These are either an approved masonry chimney or a listed residential type and building heating appliance chimney.

The selection of chimney type and its location in the house is very important. It is the chimney that makes the stove work, not the stove that makes the chimney work. That statement is worth repeating. If you were to set your new stove out in the yard and build a fire in it, it would be very difficult to keep the fire going.

A chimney actually creates a suction called draft which pulls air through the stove. There are several factors which influence draft. Some of the major factors are height of the chimney, cross section area, temperature of the chimney, and surrounding trees or buildings. In general, a short masonry chimney on the exterior of a house will give the poorest performance and a masonry chimney inside the house will work the best.

The exterior chimney can be very difficult to warm up and in extreme northern areas may not work at all. On the other hand, not only is an interior chimney easier to keep warm, but its heat loss is inside the house rather than the outside.

This guideline gives the necessary chimney requirements based on the national code (NFPA 211). However, many municipalities have their own code which differs from the national code. Local codes can vary because of climate, altitude or other factors. It is important that you check with your local building officials to find out what codes apply in your area before constructing a chimney.

MASONRY CHIMNEYS

Following is a list of the more important minimum requirements for a properly constructed masonry chimney.

- The foundation must be large enough to support the intended chimney without settling.
- The masonry wall of the chimney, if brick or modular block, must be a minimum of 4 inches nominal thickness. A mountain or rubble stone wall must be at least 12 inches thick.
- The chimney must have a fire clay flue liner (or equivalent) with a minimum thickness of 5/8-inch and must be installed with refractory mortar. There must be at least 1/2 inch air space between the flue liner and the chimney wall.
- The fire clay liner for both Model 3TD and 3TDC should measure at least 8 x 8 inches and not larger than 8 x 12 inches. 8 x 8 is preferred.
- No other appliance can be vented into the same flue.
- An airtight clean out door should be located at the base of the chimney.

- A chimney inside the house must have at least 2 inches of clearance to the combustible structure. A chimney outside the house must have at least one inch clearance to the combustible structure. Fire stops must be installed at the spaces where the chimney passes through floors and/or ceilings (Figure 5).

Figure 5

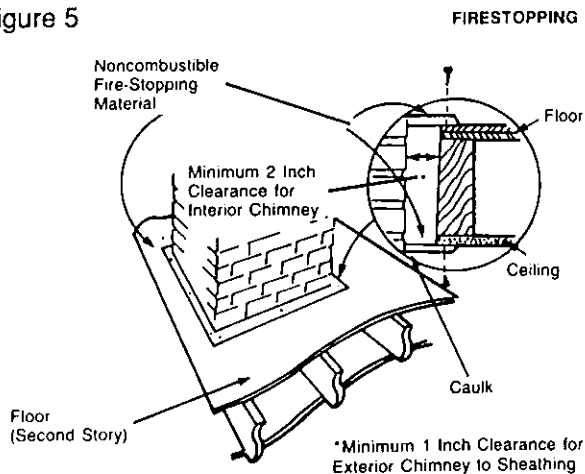

Remember that insulation must not contact the chimney. There must be air space around the chimney. Insulation must be 2 inches or more from the chimney (Figure 6).

Figure 6

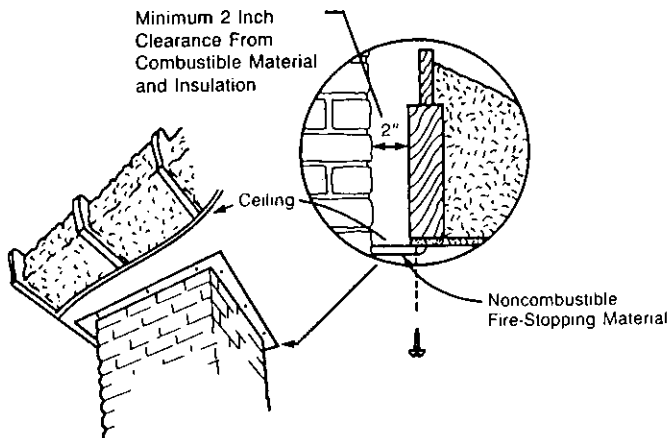

- A chimney must be the required height above the roof or other obstruction for safety and for proper draft operation. The requirement is that the chimney must be at least 3 feet higher than the highest point where it passes through the roof and at least 2 feet higher than the highest part of the roof or structure that is within 10 feet of the chimney, measured horizontally (Figure 7).

Figure 7

CHIMNEY HEIGHT

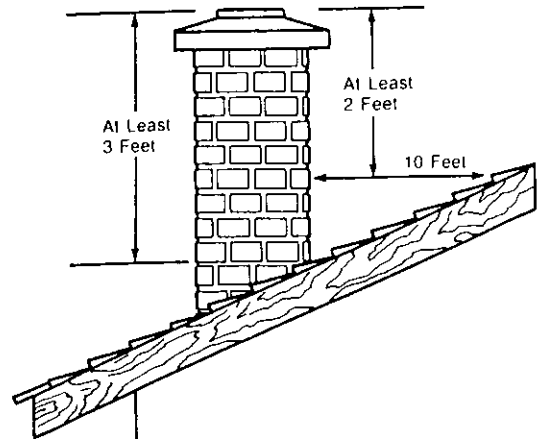

CONNECTION TO A METAL PREFABRICATED CHIMNEY

When a metal prefabricated chimney is used, the manufacturer's installation instructions must be followed precisely. You must also purchase (from the same manufacturer) and install the ceiling support package or wall pass through, "T" section package, firestops (when needed), insulation shield, roof flashing, chimney cap, etc. Maintain the proper clearance to the structure as recommended by the manufacturer. This clearance is usually a minimum of 2 inches, although it may vary by manufacturer or for certain components.

There are basically two methods of metal chimney installation. One method is to install the chimney inside the residence through the ceiling and the roof (Figures 8, 9). The other method is to install an exterior chimney that runs up the outside of the residence (Figures 10, 11). The components illustrated may not look exactly like the system you purchase, but they demonstrate the basic components you will need for a proper and safe installation.

The chimney must be the required height above the roof or other obstruction for safety and for proper draft operation (Figure 7).

REMEMBER: Follow the manufacturer's installation instructions and maintain the manufacturer's specified clearance distances.

Install an attic insulation shield to maintain the specified clearance to insulation. Insulation in this air space will cause a heat buildup which may ignite the ceiling joists

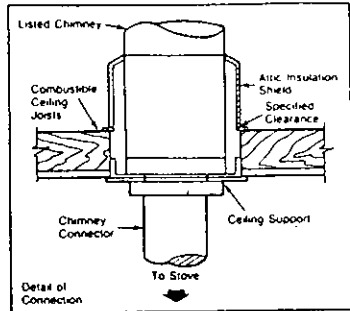

Figure 9

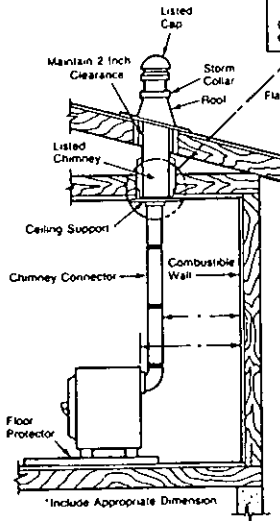

Figure 8

This method of installation requires at a minimum a ceiling support package, an insulation shield and roof flashing.

FLOOR PROTECTION

Your stove must be placed on a non-combustible surface which extends 8 inches beyond the sides and back of the stove and 18 inches in the front of the stove. This will result in an overall base which is 38" wide by 38" deep (See Figure 12).

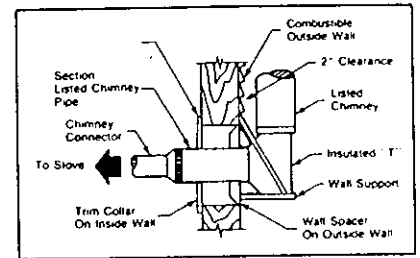

Figure 11

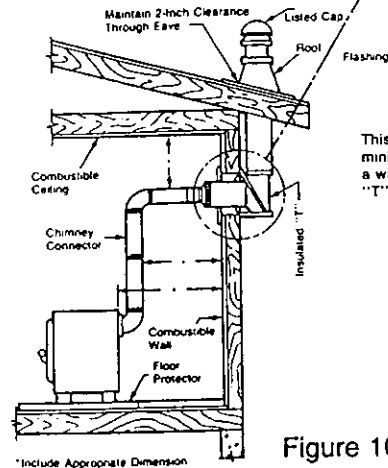

Figure 10

This method of installation requires at a minimum a wall pass through device, a wall support package and insulated "T" section and roof flashing

STOVE PLACEMENT

Good planning for stove placement involves more than just insuring you have adequately protected combustible materials. It should also consider your comfort and convenience.

The radiant heat from your stove will warm its surroundings and, in turn, the air. Will the warm air from the stove freely rise and migrate to other areas of the house? Will the stove and hearth interrupt or disturb traffic patterns in the home? Is it convenient to bring wood to the stove? These are but a few of the questions you will want to ask when choosing a site for your stove.

A simple way to visualize the area required by the stove is to cut out a piece of newspaper the same size as the stove (22" x 12-1/2"). Place the newspaper on the floor and select the appropriate dimensions from the following sections on floor and wall protection.

If the chimney connector runs to a wall adjacent to the stove, then the floor under the pipe must also be protected. The floor protector under the pipe must be 4 inches wider than the pipe or 10 inches wide for Model 3TD and 11 inches for Model 3TDC (See Figure 12B).

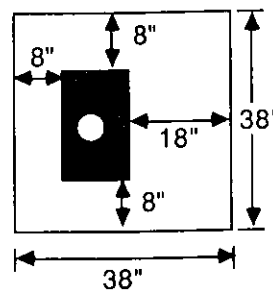

Figure 12 A.

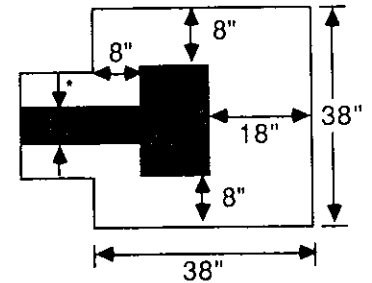

Figure 12 B.

* 2" wider than pipe on either side or 10" for 3TD, 11" for 3TDC.

During laboratory testing, it was determined that the floor protector should be 2 layers of 3/8" asbestos millboard which has a thermal conductivity (K) of less than or equal to 0.84 BTU in/ft H°F.

In recent years, asbestos millboard has become difficult to find because of the problems associated with working with asbestos. A variety of substitutes have been developed. Reputable building supply businesses have these materials. The manufacturers have furnished technical data to the building suppliers and you should be sure to tell the building supplier that you intend to use the material under a wood-stove. Asbestos millboard and similar materials can then be decorated with ceramic tiles or brick.

A number of pre-manufactured floor protectors are also available. If you choose to use one of these, make sure that it has a safety listing mark on it and never put any type of floor protection on top of carpeting.

CLEARANCES

The diagrams in Figure 13 give the clearances to maintain from unprotected combustibles. By properly protecting combustibles, these clearances can be reduced and several types of protection are available.

Figure 13 Clearances to combustibles (unshielded stove and unprotected combustible wall).

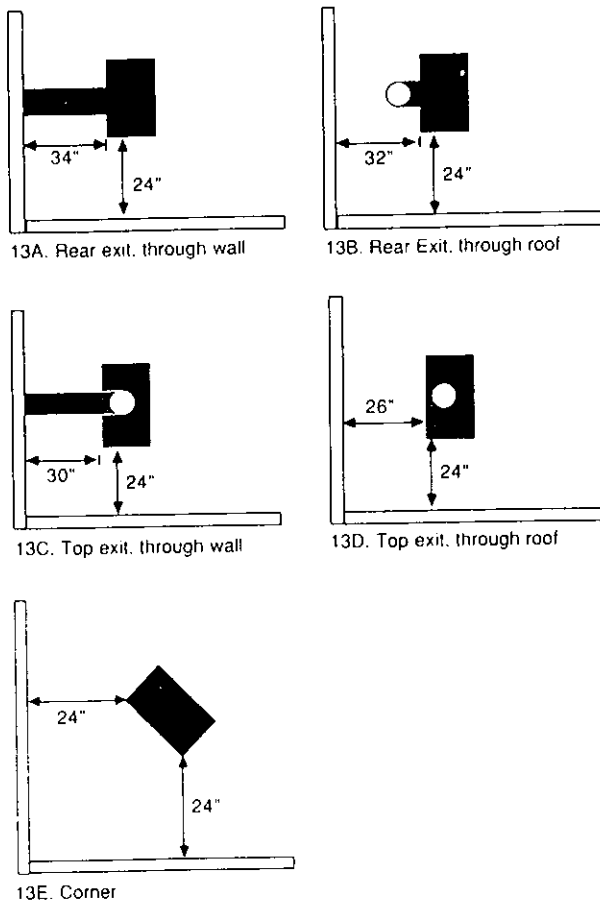

A combustible is anything that can burn and in the case of stove installations, these combustibles may not be visible. If you are not sure of the combustible nature of any material in the vicinity of your planned stove installation, you

should check with your local fire officials. Remember that "fire resistant" materials are considered combustible; they are difficult to ignite, but they will burn.

If you have recently purchased a home which has a stove hearth in it that you plan to use, it is extremely important that the entire system is examined for safety. Many older homes have faulty chimneys or have covered combustible walls or studs with brick veneers. Heat is easily conducted through brick and could ignite unseen combustibles behind it.

REDUCED CLEARANCES USING JOTUL HEAT SHIELDS AND LISTED AIR INSULATED CHIMNEY CONNECTOR

Jotul heat shield (Part 950071) mounts on the rear of the stove and allows stove installation within 18 inches of combustibles when the stove is top vented (See Figure 14).

Figure 14

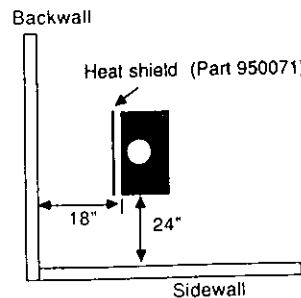
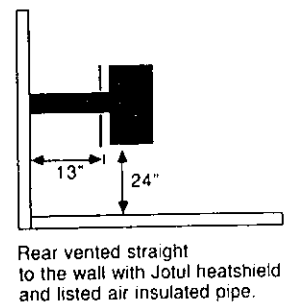
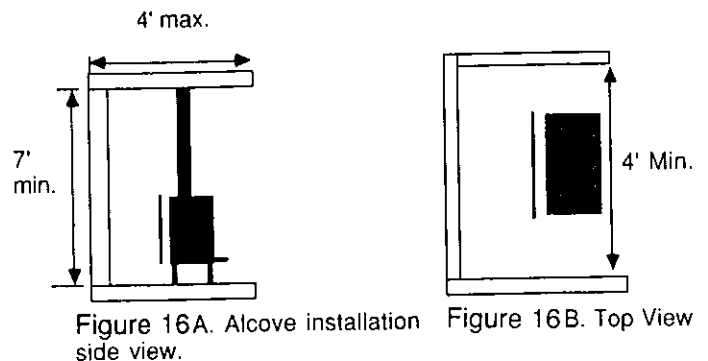

Figure 15



The same Jotul heat shield can be used in conjunction with listed air insulated pipe in rear exit installations where the pipe runs straight back to the wall. This combination permits stove placement within 13 inches of combustibles behind the stove (See Figure 15).



The Jotul 3TD and 3TDC can also be placed in an alcove which has the minimum dimensions of 7 ft. high and 4 ft. wide with a maximum depth of 4 ft. Alcove installations require the use of listed protection on the side walls, rear heat shield and listed air insulated pipe. Only top exit installations are approved for alcove installations (See Figure 16).

OTHER MEANS OF REDUCING CLEARANCES

The National Fire Protection Association Standard 211 recognizes 8 wall protection systems. The two most commonly used forms of these clearance reduction systems are galvanized steel sheet metal with a minimum thickness of 24 gauge, or 4-inch nominal thickness brick (Figures 3-5). Either of these materials must be spaced out 1 inch from the wall surface. With sheet metal, non-combustible spacers are used to maintain the 1-inch air space. With a brick wall, metal wall ties are used to anchor the brick to the wall and maintain the 1-inch air space. To avoid excessive heat transmission, the spacers or wall ties should not be placed directly behind the heater or chimney connector. The 1-inch space provides free air circulation. For best insulating results, it is essential that there are openings completely around the system, including the bottom, so that cool air can circulate in the 1-inch air space.

These two ventilated wall protectors described above will allow a 66% reduction in the required clearance to combustibles. You must, however, maintain at least 12 inches between the stove and protected combustibles at all times. For example, the necessary side wall clearance for models 3TD and 3TDC is 24 inches. Reducing this 66% would leave 8 inches. That is closer than the 12 inch minimum allowed and the stove must be kept 12 inches away.

The N.F.P.A. 211 standard goes on to say that all combustible material which is less than the required distance away must be shielded.

To determine the dimensions of a ventilated wall protector, you need to know the height of the stove, its width and what the stove's normal clearance to combustibles are.

For example, what size of ventilated wall protector will you need if you plan to rear exit your stove straight back to a wall? The necessary clearance is in Figure 13A and is 34." The stove is 28.25 inches high and 22 inches wide. A 66%, or two-thirds reduction in the required clearance would place the stove 11.22 inches away from the wall. This is less than the

minimum distance of 12 inches, so the stove must be 12 inches from the wall. Figure 17 is an overhead view of this installation.

Remember, all combustibles within the required clearance (34") must be protected. The width of the wall protector is the distance between the two points (marked X) which are 34 inches away from the stove. You can lay something of the stove width (22") on the floor 12 inches from the wall, measure out 34 inches from either end of this to the wall, and then measure between the points to find the width. If you do this, your answer is 85.66 inches.

To get the height of the wall protector, subtract the width of the stove from the wall protector width ($85.66 - 22 = 63.66$) and divide by 2. This distance, 31.83, inches, plus the height of the stove, 28.25 inches is the height of the wall protector, 60 inches.

If you like a bit of a challenge, you can determine wall protector dimensions mathematically.

You may have noticed that the overhead view in Figure 17 presented two equal right triangles with two sides given and the third side unknown. Let the 34 inch side be represented by "C," the 12 inch side be "B," and the unknown side be "A."

Use the equation $A^2 = C^2 - B^2$ to find the length of the unknown side and solve as follows:

$$A^2 = (34)^2 - (12)^2$$

$$A^2 = 1156 - 144$$

$$A^2 = 1012$$

$$A = \sqrt{1012}$$

$$A = 31.8$$

Figures 18 and 19 show typical ventilated wall protectors.

FIREPLACE VENTING AND CLEARANCES

The Jotul Models 3TD and 3TDC may also be connected to a masonry fireplace. They may not be vented into any type of "zero clearance" or manufactured fireplace.

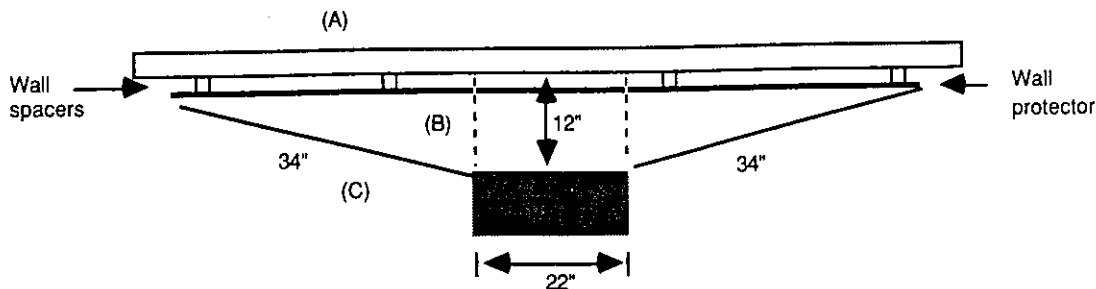

Figure 17 Reduced clearances with wall protector.

If wood mantels or trim are present on the fireplace, then the Jotul fireplace shield, part 350073, must be used. Figure 20 gives the clearances to combustible trims and mantels that must be maintained when using the fireplace shield.

Figure 18

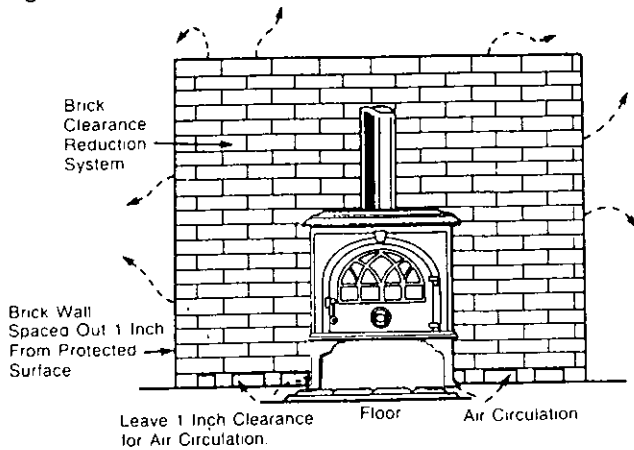
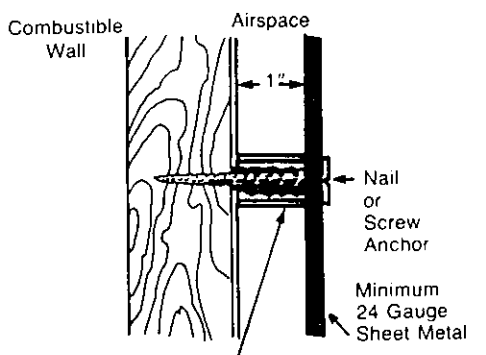

Figure 19



1 Inch Non-Combustible Spacer Such As Stacked Washers, Small Diameter Pipe, Tubing, or Electrical Conduit.

Do Not Use Fasteners Directly Behind Chimney Connector or Stove

CONNECTION TO A MASONRY FIREPLACE

There are several kits available to connect the stove to a masonry fireplace. Look for a listed kit. The kit is an adapter which is installed at the location of the fireplace damper. The existing damper may have to be removed to allow installation of the kit. The key points of this type of stove connection are that the connector pipe must extend up the chimney above where the fire clay liner starts, and the areas of the kit installation and connector penetration should fit tightly and be sealed with high temperature furnace cement unless the kit's instructions state otherwise (Figure 21). The tight fitting installation aids the proper draw of the chimney.

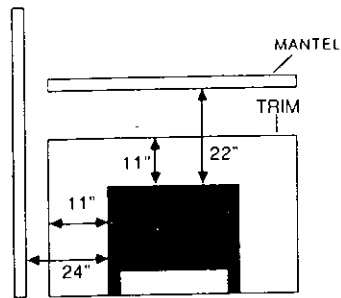

Figure 20 Fireplace installation

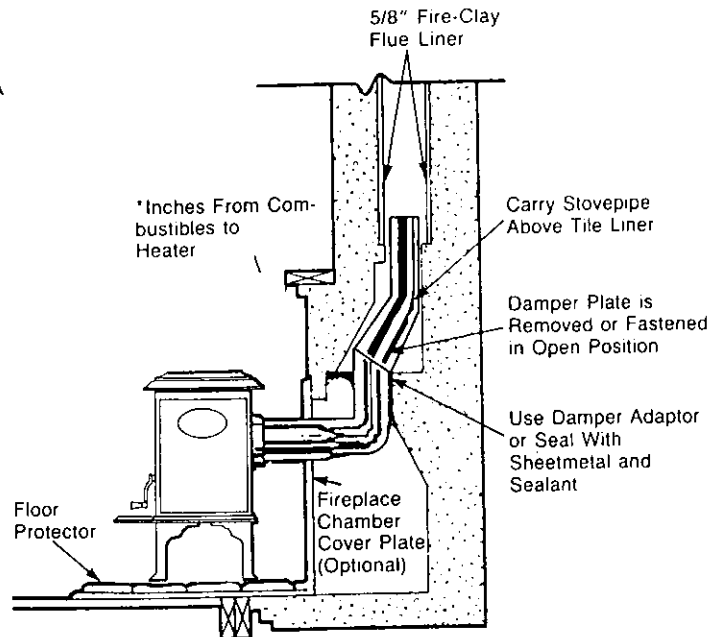

Figure 21

4. Assembly

In order to prevent shipping damage, several parts of your stove have been removed and packed separately. These parts are:

DIAGRAM # (see page 1)	DESCRIPTION	QUANTITY
38	Wooden knob	1
40	Handle bushing	1
41	Handle washer	1
42	6mm x 35mm handle screw	1
43	6mm x 20mm leg bolts	4
44	6mm x 16mm ash lip bolt	1
45	sq. leg bolt washers	4
36	Ash lip	1
32	Flue outlet	1
35	Leg	4
37	Ash retainer	1
46	Bottom heat shield	1
47	Screen	1

TO ASSEMBLE:

1) Lift the top of the stove off and remove the top baffle and back and side burn plates. Parts #5, 7, 8 and 9.

2) Attach the bottom heat shield (46) and legs. The heat shield is sandwiched between the legs and the bottom of the stove. The two channels on the heat shield which hold the fire screen should face the floor. Do not over tighten the leg bolts.

3) Stand the stove up and bolt on the ash lip (36,44).

4) Flue outlet. All Model 3 stoves are delivered with the top outlet covered. To top vent the stove, remove the cover (13) and traverse bar (12) and replace them in the rear outlet position.

5) Attach the flue outlet collar in the desired location with the three 6 x 16mm bolts. On Model 3TDC the catalyst housing serves as the flue outlet. When mounting the catalyst, be sure to orient the hole for the probe thermometer so that it will be visible.

6) Replace the burn plates and baffles removed in Step One.

7) The ash/log retainer (37) drops into place and rests in a shallow groove in the bottom burn plate.

8) Attach the door handle, Parts 42, 39, 38, 40 and 41 as shown on the parts diagram.

OPTIONAL EQUIPMENT

The following optional equipment is available for the Jotul Fireplace Stove.

Description:

1. Short legs (101952) -- will reduce the stove height by 2-1/4"
2. Fireplace shield (350073) -- to protect combustible mantels and trim
3. Reduced clearance shield (950071) -- allows closer installation to unprotected rear walls
4. Catalyst (5000) -- basic Model 3TD stoves can be converted to Model 3TDC's at any time by replacing the flue outlet with the catalyst and housing

For installation and assembly, please follow the instructions supplied with the optional equipment packages.

5. Operation

BEFORE BUILDING A FIRE IN YOUR NEW JOTUL FIREPLACE STOVE, PLEASE READ THE FOLLOWING SECTION CAREFULLY.

USE ONLY SEASONED WOOD AS FUEL. AVOID USING TREATED, PAINTED, OR ROTTEN WOOD. NEVER USE GASOLINE, GASOLINE TYPE LANTERN FUEL, KEROSENE, CHARCOAL LIGHTER FLUID, OR SIMILAR LIQUIDS TO START OR "FRESHEN UP" A FIRE IN THIS HEATER. KEEP ALL SUCH LIQUIDS FAR AWAY FROM THE HEATER WHILE IT IS IN USE.

WOOD STORAGE

When storing wood outside, it should be covered from the elements and stored off the ground. Make certain that the woodpile has good air circulation through it in order to promote drying to aid in the seasoning process.

To obtain the most benefit from the wood you burn, use only seasoned wood which has been cut and split for at least one year. Burning unseasoned or wet wood causes rapid development of creosote, while reducing the heat value of the wood being burned.

CREOSOTE AND SOOT FORMATION AND THE NEED FOR REMOVAL

When wood is burned slowly, it produces tar and other organic vapors which combine with expelled moisture to form creosote. These creosote vapors condense in the relatively cool chimney flue of a slow-burning fire. The creosote that accumulates in the flue is highly flammable and is the fuel of chimney fires. To prevent a chimney fire, the creosote needs to be removed by sweeping the chimney and flue connector. The frequency of sweeping will depend on how you operate your stove, but it is important to visually inspect the flue after every two weeks of use. An accumulation of 1/4" or more on the sides of the flue or connector is considered hazardous and should be removed.

In the event that creosote in your chimney or flue connector ignites, the resulting fire is often accompanied by a roaring noise and a crackling sound as flakes of burned creosote break loose. If you suspect you are having a chimney fire, immediately close the draft regulator and make sure the door is closed. Call the fire department and get everyone out of the house.

Trying to extinguish the fire in the stove will not help; in fact, it can make matters worse by allowing oxygen through the door, which then supports the fire in the chimney. When the roaring and crackling has stopped, you should resist the temptation to open the door and look at the fire. The fire may have suffocated but could

rekindle when you open the door. After a chimney fire, do not use your stove until the chimney and the flue connector have been cleaned and inspected to insure that no damage has been sustained.

BREAKING IN YOUR STOVE

A cast iron stove should be "broken in" much in the same way a new car with a cast iron engine is: gradually. It is mandatory that five consecutive small fires be built in the stove prior to operating the stove continuously. Each fire should be a little larger than the previous one and the last fire should be a full sized load. Allow the stove to cool completely between fires. Breaking in your stove this way works much like an athlete limbering up before competing.

BUILDING A FIRE

Prior to building your first fire, it is a good idea to burn just one or two sheets of newspaper to make sure all of your connections are good and the chimney is drafting properly. To build a fire, place three or four crumpled sheets of newspaper on the bottom of the stove and pile a handful of kindling on top of the paper. Light the paper, close the door and slide the draft control all the way to the right which is the full open position. When the kindling is burning well, add a few pieces of medium to normal size wood. If the fire does not become well established, you may not have used enough kindling, added too much oversized wood or used green wood. When the fire is burning well and in no danger of dying out, you can vary the draft to regulate the rate of burn and heat output. When the draft slide is to the far left it is closed and no air will reach the fire. The fire and heat output will intensify as the slide is moved to the right.

REFUELING

The stove is ready to be refueled when the logs have been reduced to glowing embers. A few minutes before refueling open the draft slide fully. This allows smoke and gases to clear the stove and intensifies the heat in your coals so that your new fuel will ignite rapidly.

When you open the door, just crack it, and pause a few seconds before opening it the rest of the way. Do this whenever you open the door, whether you are refueling or just checking on the fire. Under high temperature and low oxygen conditions an accumulation of unburned gases may exist inside the stove, and opening the door fully could allow fresh oxygen in, igniting these gases with explosive force. Poke the embers into an even bed, add the new fuel and close the door. Leave the draft regulator fully open until the new fuel is burning well. By waiting until the new fuel is burning well before closing down the draft, you can reduce the rate of creosote formation in your flue.

The first few times you fire your stove you may notice it "sweating." This is normal. Moisture forming on the outside of the stove should immediately be wiped off to prevent it from staining the stove.

Do not overfire. Using flammable liquids, too much wood, or burning trash in the stove may result in overfiring. If the chimney connector or stove glows red or worse, white, the stove is overfired. This condition may ignite creosote in the chimney, possibly causing a house fire.

If you overfire, immediately close the draft control and door (if open) to reduce the air supply to the fire.

DISPOSAL OF ASHES

After several days of burning it will be necessary to remove some ashes from the stove. Ashes should be placed in a metal container with a tight-fitting lid. The closed container of ashes should be placed on a non-combustible floor or on the ground, well away from all combustible materials, or outdoors pending final disposal. If the ashes are disposed of by burial in the soil or otherwise locally dispersed, they should be retained in a closed container until all cinders have thoroughly cooled.

Do not remove all of the ashes from the stove. The stove will perform better if you maintain a one-inch layer of ashes in the bottom.

6. Maintenance

At least once a year you should perform a routine maintenance check. A good time to do this is when you are cleaning the chimney and connector. Of course you should clean the chimney and connector whenever accumulations of soot and creosote reach 1/4" thick, which may be several times a year, depending on how the stove is operated.

MAINTENANCE CHECK;

- 1) Inspect the entire stove and replace any cracked parts.
- 2) Inspect all joints for leaks or missing furnace cement. Disassemble, clean, and re-cement.
- 3) Check door and top gasket. Replace worn gaskets with 3/8" braided fiberglass gasket. Loose gaskets can be re-cemented.

At the end of the heating season remove all of the ashes from the stove. Take out the burn plates and paint or lightly oil the inside of the stove and burn plates to prevent rust.

7. Catalyst Operation for Model 3TDC

Model 3TDC is equipped with a catalyst coated ceramic honeycomb and a probe thermometer (See Figure 22). Normally gases liberated from the combustion of wood require a temperature of 1,200°F to ignite. The catalyst on the ceramic honeycomb will allow these same gases to start burning at a temperature of 500° to 550°F.

To build a fire in Model 3TDC follow the same procedure as outlined for Model 3TD except for the following:

Before building a fire rotate the ceramic honeycomb with the removable wooden handle to the bypass position. The arrow on the bypass handle is in line with the honeycomb. When the arrow is parallel to the stovepipe, the honeycomb will also be parallel to the stovepipe and therefore will be bypassed. Use the removable handle to rotate the catalyst to the bypass position whenever you open the door of the stove.

Since the catalyst does not activate until it reaches the 500°F range you do not want to swing the catalyst into the active position until your probe thermometer indicates you have reached these temperatures.

Observe the probe thermometer for several minutes after you have closed the bypass. If the temperature begins to fall below 500°F, the catalyst was not sufficiently preheated before closing the bypass. Generally catalytic "light off" is accompanied with a sharp rise in temperature. For the first few hours of the burn cycle temperatures should average around 700°F on the probe thermometer. Brief periods of high temperatures are not harmful to the catalyst or the ceramic honeycomb but you should avoid operating the catalyst above 1,800°F. If your stove is operating at these temperatures, decrease the draft and, if necessary, open the bypass. Temperatures above 1,800°F can reduce the life of your catalyst and are a result of too much "smoke" reaching the catalyst. Finely split wood, pitchy pine or tightly packed loads can overwork the catalyst. It is best to use wood that is 4 to 7 inches in diameter and load the stove frequently with medium sized loads.

ADDING FUEL TO MODEL 3TDC

At the end of the burn cycle there will be very little smoke reaching the catalyst and the catalyst could go out before adding new wood. The introduction of new fuel can also cool off the stove enough to deactivate the catalytic combustion.

If the catalyst goes out (temperatures below 600°F) repeat the procedure used in starting a fire to get it going again.

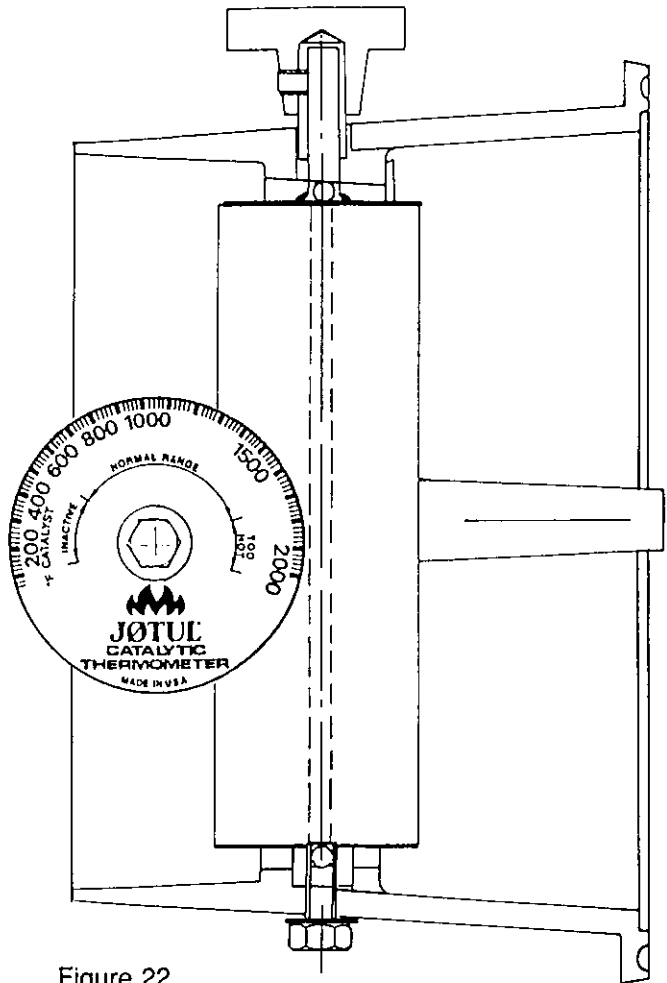

Figure 22

CATALYST INSPECTION AND MAINTENANCE

Your catalyst is equipped with a probe thermometer which gives the best indication of whether or not your catalyst is working. If you are unable to maintain temperatures above 600°F on your probe thermometer, your catalyst is not working. Other indications that the catalyst is not working are thick smoke coming from the chimney or greatly reduced draft with the catalyst in the closed position.

You should visually inspect your catalyst several times a season to make sure it is clean and intact.

The catalyst can be inspected by removing the chimney connector or on rear exit stoves by lifting the top off the stove.

If you suspect your catalyst is not working, review the light off procedures. Make sure the catalyst has been sufficiently heated before closing it. The catalyst may not be getting hot enough or you have reduced the fire to too cool a temperature after closing the catalyst. If this fails to activate the catalyst, there may be a coating of ash or creosote on the catalyst honeycomb surface. If the honeycomb is coated with ash or creosote, the catalyst cannot come into contact with the smoke passing over it.

Ash can be removed with a clean soft bristled paintbrush. If the catalyst is coated with creosote (a dark, resinous or crusty material), this indicates that the stove has been operating at too low a temperature. Creosote normally won't deposit on surfaces hotter than 300°F.

Creosote buildup on the catalyst could also indicate that your chimney and connector have similar buildups and should be cleaned.

Creosote buildup on the catalyst can be removed by burning it off, using a hot fire in the stove for several minutes.

UNDER NO CIRCUMSTANCES ATTEMPT TO BURN CREOSOTE OFF A CATALYST UNLESS YOU ARE ABSOLUTELY SURE YOUR CHIMNEY AND CONNECTOR ARE CLEAN. YOU COULD START A CHIMNEY FIRE.

A good hot fire (900°F) will remove the creosote and not harm your catalyst. If a creosote buildup reoccurs, you may need to adjust your operating procedures to burn hotter fires.

If you are unable to get your catalyst to operate, it should be returned to the catalyst manufacturer for replacement. **MAKE SURE YOU FILL OUT THE SEPARATE CATALYST WARRANTY WHICH IS PACKED WITH THE CATALYST AND SEND IT TO THE MANUFACTURER WHEN YOU INSTALL YOUR STOVE.**



JOTUL USA, INC.
P.O. BOX 1157
PORTLAND, ME 04104