

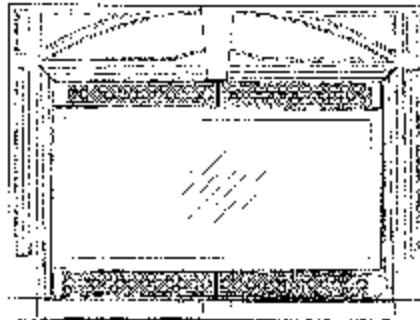

Jøtul GI 450 DV Katahdin
Direct Vent Gas Fireplace Insert



Installation and Operation Instructions

CAUTION: THESE INSTRUCTIONS MUST REMAIN WITH THE HOMEOWNER.

WARNING: If the information in these instructions is not followed exactly, a fire or explosion may result causing property damage, personal injury or loss of life.

- Do not store or use gasoline or other flammable vapors and liquids in the vicinity of this or any other appliance.
- **WHAT TO DO IF YOU SMELL GAS**
 - Do not try to light any appliance.
 - Do not touch any electrical switch; do not use any phone in your building.
 - Immediately call you gas supplier from a neighbor's phone. Follow the gas supplier's instruction.
 - If you cannot reach your gas supplier, call the fire department.
- Installation and service must be performed by a qualified installer, service agency or the gas supplier.
- In the Commonwealth of Massachusetts, a carbon monoxide (CO) detector shall be installed in the same room as the appliance.

ATTENTION : CES INSTRUCTIONS DOIVENT DEMURER AVEC LE PROPRIÉTAIRE D'UNE MAISON.

AVERTISSEMENT: Assurez-vous de bien suivre les instructions données dans cette notice pour réduire au minimum le risque d'incendie ou d'explosion ou pour éviter tout dommage matériel, toute blessure ou la mort.

- Ne pas entreposer ni utiliser d'essence ni d'autres vapeurs ou liquides inflammables dans le voisinage de cet appareil ou de tout autre appareil.
- **QUE FAIRE SI VOUS SENTEZ UNE ODEUR DE GAZ:**
 - Ne pas tenter d'allumer l'appareil.
 - Ne touchez à aucun interrupteur. Ne pas vous servir des téléphones se trouvant dans le bâtiment où vous trouvez.
 - Appelez immédiatement votre fournisseur de gaz depuis un voisin. Suivez les instructions du fournisseur.
 - Si vous ne pouvez rejoindre le fournisseur de gaz, appelez le service des incendies.
- L'installation et l'entretien doivent être assurés par un installateur ou un service d'entretien qualifié ou par le fournisseur de gaz.



Jøtul GI 450 DV Katahdin Direct Vent Gas Fireplace Insert

Manufactured and Distributed by:
Jøtul AS
 Fredrikstad, Norway
Jøtul North America
 Gorham, Maine 04038 U.S.A.

Test Standards

This appliance complies with U.S. and Canadian National Safety Standards and is tested and listed by Intertek Testing Services of Middleton, Wisconsin to:
 ANSI Z21.88-2005,
 ANSI Z21.88a / CSA 2.33a - 2007,
 CAN/CGA 2.17 -M91, and CSA P.4-01.2.



New York City Dept. of Buildings MEA No. 312-00-E

**THIS PRODUCT MUST BE INSTALLED
 BY A LICENSED PLUMBER OR
 GAS-FITTER WHEN INSTALLED IN THE
 COMMONWEALTH OF MASSACHUSETTS.**

**NATIONAL
 FIREPLACE
 INSTITUTE**



CERTIFIED

www.nficertified.org

We recommend that our gas hearth products be installed and serviced by professionals who are certified in the U.S. by the National Fireplace Institute® (NFI) as NFI Gas Specialists.

Table of Contents:

Specifications	4
General Information	5
Minimum Fireplace Dimensions	6
Installation Requirements	6
Masonry Fireplace Installation	8
Prefabricated (factory-built) Installation	9
Clearance Requirements	10
Hearth Requirements	10
Gas Conversion	11
Gas Connection	12
Gas Pressure	13
High Altitude Adjustment	14
Flame Adjustment	15
Logset Installation	15
Blower Operation	16
Wall Thermostat	17
Remote Control	17
Surround Panel Installation	18
Checking the System	19
Fireplace Operation	20
Maintenance	20
Service Log	21
Illustrated Parts Diagram	22
Replacement Parts	23
Antique Brick Panel Kit	24
Appendix / Log Levelers	26
Lighting Instructions	BACK COVER

THIS OWNER'S MANUAL PROVIDES INFORMATION TO ENSURE SAFE INSTALLATION AND EFFICIENT, DEPENDABLE OPERATION OF YOUR FIREPLACE INSERT. PLEASE READ THESE INSTRUCTIONS IN THEIR ENTIRETY AND MAKE THEM AVAILABLE TO ANYONE USING OR SERVICING THIS GAS INSERT.

DO NOT ATTEMPT TO ALTER OR MODIFY THE CONSTRUCTION OF THIS APPLIANCE OR ITS COMPONENTS. ANY MODIFICATION OR ALTERATION WILL VOID THE WARRANTY, CERTIFICATION AND LISTING OF THIS APPLIANCE.

GI 450 DV Katahdin Specifications

MEASUREMENTS INCLUDE THE FRONT GRILL ASSEMBLIES AND ARE NOT TO SCALE.

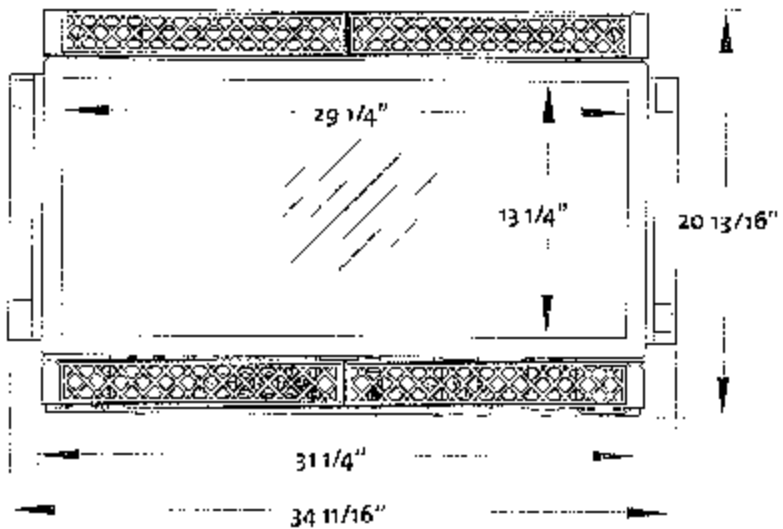
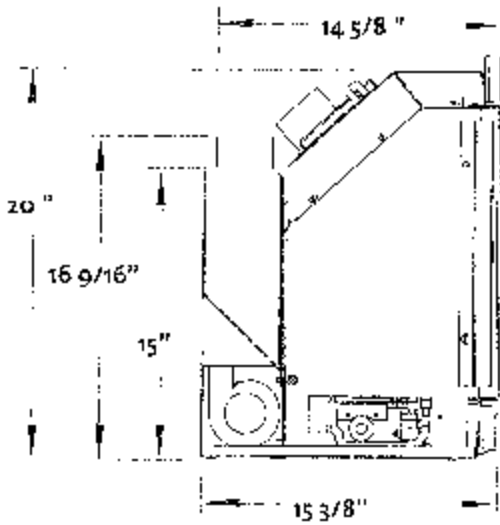
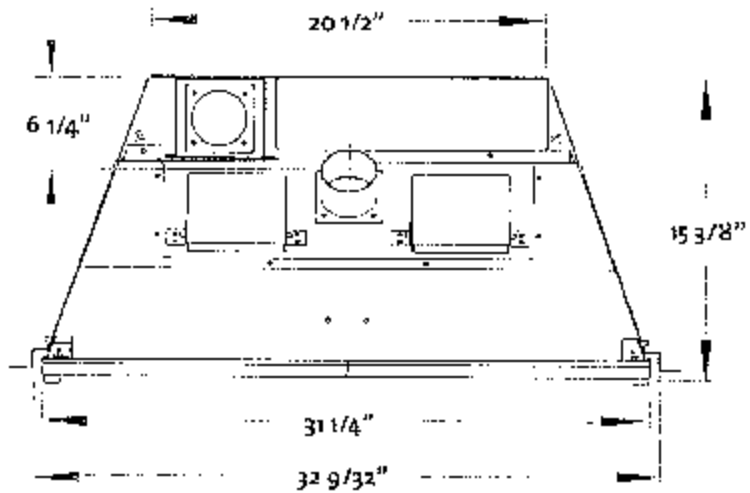

Input Rates

Natural gas

33,000 BTU/hr. maximum input

26,000 BTU/hr. minimum input

Propane

33,000 BTU/hr. maximum input

26,000 BTU/hr. minimum input

THIS APPLIANCE IS SHIPPED TO USE NATURAL GAS ONLY. FOR USE WITH PROPANE, INSTALL PROPANE CONVERSION KIT #154903, INCLUDED WITH THIS APPLIANCE.

Suggested Tool List for Installation and Maintenance

- External regulator (for LP only)
- Piping which complies with local code
- Manual shutoff valve
- Sediment trap
- Tee joint
- Pipe wrench
- Pipe sealant
- 10mm open end wrench
- 1/2", 7/16" open end wrench
- Phillips head screwdriver
- Flat head screwdriver
- 1/4" nut driver
- Gloves
- Safety glasses
- Torx T20 screwdriver
- Leak test solution

General Requirements

- THIS HEATER MUST BE INSTALLED AND MAINTAINED BY A QUALIFIED SERVICE AGENCY.
- The installation and repair of this appliance must be done by a qualified service person. Failure to properly install and maintain this heater could result in an unsafe or hazardous installation, which may result in a fire, explosion, property damage, personal injury or loss of life.
- This appliance should be inspected before use and at least annually. More frequent cleaning may be required due to excessive lint from carpeting, bedding material, etc. It is imperative that control compartments, burners and circulating air passageways of the appliance be kept clean.
- S'assurer que le brûleur et le compartiment des commandes sont propres. Voir les instructions d'installation et d'utilisation qui accompagnent l'appareil.
- The installation must conform to local codes. Your local Jøtul dealer can assist you in determining what is required in your area for a safe and legal installation. Some areas require a permit to install a gas burning appliance. Always consult your local building inspector or authority having jurisdiction to determine what regulations apply in your area.
- Your local officials have final authority in determining if a proposed installation is acceptable. Any requirement that is requested by the local authority having jurisdiction, that is not specifically addressed in THIS manual, defaults to local code. In the absence of local codes, the installation requirements must comply with the current National codes. In the U.S., these requirements are established in the National Fuel Code, ANSI Z223.1 (NFPA 54). In Canada, the codes have been established in CAN/CGA B149 Fuel Installation Code.
- Installer l'appareil selon les codes ou règlements locaux, ou, en l'absence de tels règlements, selon les Codes d'installation CAN/CGA-B149.
- DO NOT OPERATE THIS INSERT IF ANY PART HAS BEEN UNDER WATER.
- Immediately call a qualified service technician to inspect the heater and to replace any part of the control system and any gas control which has been under water.
- Ne pas se servir de cet appareil s'il a été plongé dans l'eau, complètement ou en partie. Appeler un technicien qualifié pour inspecter l'appareil et remplacer toute partie du système de contrôle et toute commande qui ont été plongés dans l'eau.
- Do not operate this appliance with the glass front removed, cracked or broken. Replacement of the glass should be done by a licensed or qualified service person. Only remove glass for routine service. Always handle glass carefully.
- Pour utilisation avec les portes en verre conformes avec l'appareil seulement ou Ne pas utiliser avec des portes en verre.

Safety Notices

Your fireplace insert will reach high surface temperatures during normal operation. Please note the following safety considerations.

- Due to the high operating temperatures this appliance should be located out of traffic and away from furniture and draperies.
- Children and adults should be alerted to the hazards of high surface temperatures and should stay away to avoid burns or clothing ignition.
- Young children should be supervised while they are in the same room as the Katakhdin gas insert.
- Clothing or other flammable materials should not be placed ON or NEAR the Katakhdin gas insert.
- Surveiller les enfants. Garder les vêtements, les meubles, l'essence ou autres liquides à vapeur inflammables loin de l'appareil.
- NEVER store or use gasoline or any other flammable vapors or liquids in the vicinity of the Katakhdin gas insert.
- Never burn any other materials in your Katakhdin gas insert, it is strictly designed for use with natural gas or propane fuel ONLY.
- Any safety screen, glass or guard removed for servicing the appliance must be replaced prior to operating the appliance.

Minimum Fireplace Requirements

This appliance has been specifically designed to be installed into a solid fuel-burning prefabricated fireplace OR a code-approved solid fuel-burning masonry fireplace with a tile flue liner.

Figure 1.

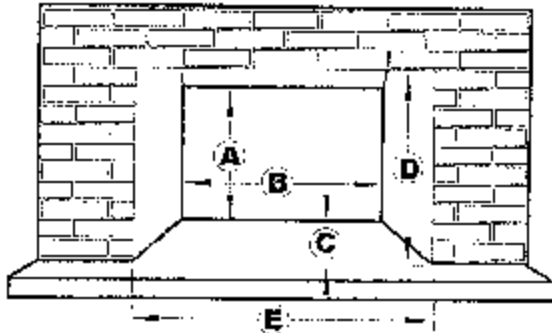

Minimum Fireplace Dimensions

- A - Inside Height = 17" (431 mm)
- B - Inside Width = 21" (533 mm) (at 15" of depth)
- C - Inside Depth = 15"
- D - Opening Height = 20"
- E - Opening Width = 32 1/2"

Maximum Fireplace Opening

Standard Surround:

Will cover a maximum fireplace opening 27 1/2" high x 39" wide.

The overall Standard Surround dimensions are 28" high X 40" wide.

Standard Surround with 2" Riser Bar:

Will cover a maximum fireplace opening 29 1/2" high x 39" wide

The overall Standard Surround dimensions with the Riser Bar are 30" high X 40" wide.

Optional Wide Surround (must be used with Standard Surround):

Will cover a maximum fireplace opening 31 1/2" high X 47" wide.

The overall Wide Surround dimensions are 32" high X 47 5/8" wide.

NOTE: A pair of Leg Extensions is Included with the Wide Surround for installations that include the 2" Riser Bar.

SEE PAGE 19 FOR SURROUND AND RISER BAR INSTALLATION INSTRUCTIONS.

SEE THE APPENDIX ON PAGE 26 FOR DETAILS CONCERNING USE OF THE LEG LEVELER BRACKETS TO ADJUST THE HEIGHT OF THE UNIT.

Do not modify or alter the construction of the gas insert or any of its components to enable it to fit into a fireplace. Any modification of the insert is potentially dangerous and will void the warranty, certifications and approvals.

Installation Requirements

Prior to installation, the existing chimney exhaust flue must be thoroughly cleaned and completely inspected by a qualified chimney sweep or fireplace service technician.

Do not install this appliance into a damaged chimney, unless effective repairs can be made prior to installation. If you are unsure of the condition of your fireplace and chimney, contact a professional fireplace service technician or your local Jøtul Authorized Dealer to assist you in determining the condition of your fireplace and chimney.

THIS APPLIANCE MUST NOT BE CONNECTED TO A CHIMNEY OR FLUE SERVING ANY OTHER APPLIANCE OF ANY KIND.

All venting components must be installed in accordance with the terms of their listing and manufacturer's instructions. Refer to the pipe manufacturer's instructions for proper pipe clearances.

This appliance is specifically designed to operate using 3" Type B vent pipe components or a Listed Flexible gas liner.

Vent Guidelines

- All vent components must be installed in accordance with the terms of their listing and manufacturer's instructions.
- The minimum height of termination cap from the top of the unit shall be no less than 10', and the maximum height shall be no more than 35'. See figures 2 and 4.
- Steep roofs, nearby trees, or predominantly windy conditions can promote weak draft or occasional downdrafts. In such cases, increasing the height of the vent or installation of high wind termination caps may alleviate the condition.
- **HORIZONTAL RUNS are not permitted anywhere in the venting system.**
- Venting liners CANNOT be less than 3" in diameter or greater than 3" in diameter.
- Any unused flue or masonry enclosure can be used as a passageway for venting PROVIDED the flue is relined using 3" Listed Flexible Gas Liner.
- The remaining space around the liner in a masonry or zero-clearance flue CANNOT be used to vent any other appliance.
- Listed Flexible Gas Liners may not be exposed to any living space.
- Installation of any components not manufactured or approved by Jøtul or failure to meet all clearance requirements will void all warranties and could result in property damage, bodily injury, or loss of life.
- Never modify any venting component, or use any damaged venting product.
- **THE GAS APPLIANCE AND VENT SYSTEM MUST BE VENTED DIRECTLY TO THE OUTSIDE OF THE BUILDING, AND NEVER ATTACHED TO A CHIMNEY SERVING A SOLID FUEL OR GAS BURNING APPLIANCE.**
- The minimum vent height above the roof or adjacent walls is specified by building codes. A general guide to follow is the Gas Vent Rule below.

GAS VENT RULE

ROOF SLOPE	Minimum Height from Roof
Flat to 6/12	1'0" 0.3M
Over 7/12 to 9/12	2'0" 0.6M
Over 10/12 to 12/12	4'0" 1.2M
Over 13/12 to 16/12	6'0" 1.8M
Over 17/12 to 21/12	8'0" 2.4M

Vent Installation Procedure

The GI 450 DV Katahdin gas insert must be vented through dual 3" flexible gas aluminum liners listed for use with gas appliances.

This co-linear installation includes a pair of 3" flex ducts that run from the insert up through the existing chimney.

One duct is attached to the exhaust port on the back of the unit and will carry the exhaust gases to the outside of the house. This exhaust liner must run the full length of the chimney and be directly connected to the chimney termination cap. See figure 2.

The other 3" liner will be attached to the intake port on the back of the unit and will provide fresh air for combustion to the unit. This liner must extend a **minimum of 6'** off the back of the unit and extend through the damper area of the fireplace and into the tile liner of the chimney. This liner can also extend the full length of the chimney and connect to the termination cap. See figures 2 and 4.

VERY IMPORTANT

If the intake flex *does not* extend the full length of the chimney and connect to the unit and the termination cap - **A METAL BLOCK OFF PLATE MUST BE CONSTRUCTED AND INSTALLED ABOVE THE UNIT BELOW THE END OF THE INTAKE DUCT** (normally at the damper area). See figure 2.

To avoid cross venting the insert, label the duct to be used for the exhaust conduit at both the top and bottom ends. This ensures that the exhaust duct will be attached to the correct collar on the insert and on the chimney termination kit.

CANADA NOTE: Both Intake and Exhaust ducts must extend the full length of the chimney and be connected to both the unit and the termination kit.

VERY IMPORTANT NOTICE:

THE USE OF AN EXISTING CHIMNEY AS AN AIR INTAKE IS NOT COVERED UNDER THE ANSI Z21.88-1999-CSA 2.33-M99 TEST METHODS AND RESULTING ITS/WHI PRODUCT CERTIFICATION. THE CODE AUTHORITY HAVING JURISDICTION MUST BE CONSULTED PRIOR TO PROCEEDING WITH THIS INSTALLATION METHOD.

Venting through a Masonry Fireplace

1. Measure height of the chimney to fireplace opening. Determine if both the intake and exhaust will be extended to the top of the chimney. **In Canada, both liners must extend the full length of the chimney and be connected to both the unit and the termination kit.**
2. Cut the appropriate lengths of flex duct for both the intake and exhaust. Label both ends of the Exhaust duct.
3. Follow the manufacturer's instructions to attach the ends of the duct(s) to the chimney termination kit as appropriate.
4. Drop the liners down the chimney from the top and rest the termination kit atop the chimney.
5. Seal the chimney termination kit to the top of the chimney flue with high temperature sealant.
6. Secure the appropriate direct vent cap to the termination kit.
7. Inside the fireplace, fully extend the duct and trim any excess so that the ends hang approximately 15" from the floor of the fireplace.
8. If the intake duct is not attached to the chimney termination kit:
 - A. Install a minimum 6 foot length flex duct for the up the flue.
 - B. A METAL block-off plate must be constructed and installed in the damper area to completely seal off the flue from the room. Cut holes in the plate for both the Intake and Exhaust liners.
 - C. A direct vent cap is required to allow fresh air into the chimney flue and ultimately into the intake duct to the insert.
9. Compress the ducts so that they are hanging above the height of the fireplace opening and are out of the way.
10. Position the insert without surround panels half-way inside the fireplace and attach duct you labelled Exhaust to the Exhaust collar on the insert. Both Intake and Exhaust collars are labelled.
11. Secure the ducts to the collars with sheet metal screws or hose clamps. No silicone or sealant is required.
12. Once the gas line is installed, carefully push the unit inside the fireplace.

See page 13 for gas line gas line connection.

See page 19 for surround panel installation.

Fig. 2. Venting through fireplace chimney.

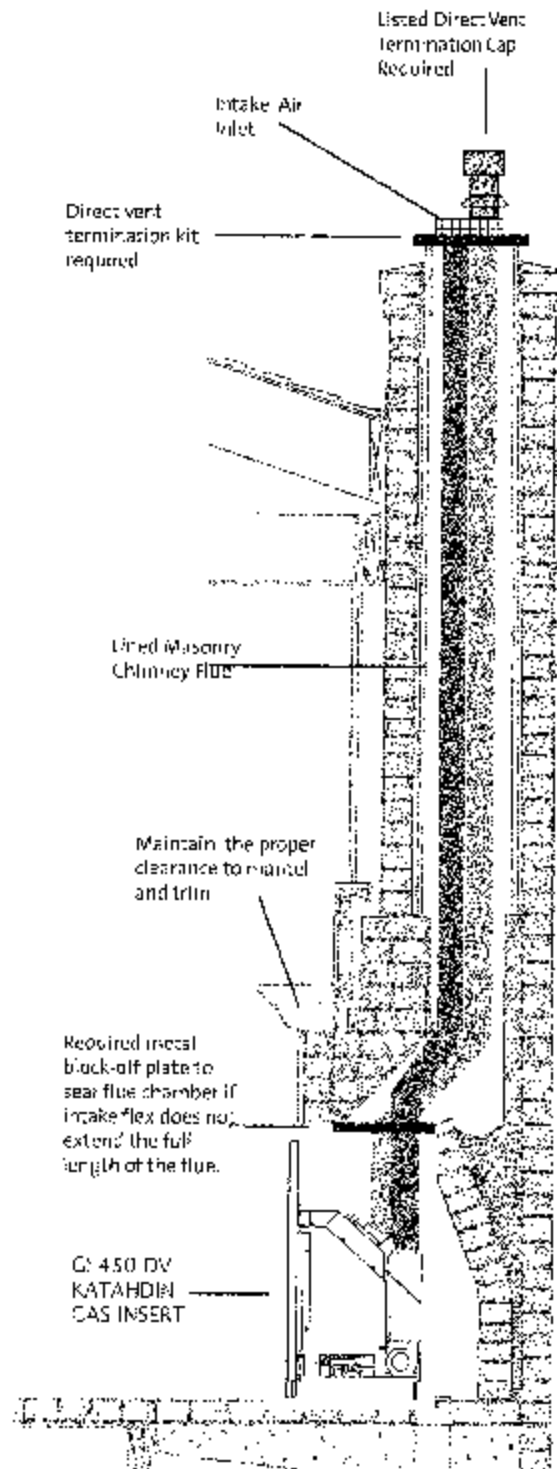

Warning: Failure to position the parts in accordance with this diagram or failure to use only parts specifically approved with this appliance may result in property damage or personal injury.

Prefabricated Fireplace Installation

A factory-built fireplace will require modification prior to installation of the insert.

Modification

1. Remove any fuel grate and other components if attached. On most models, the firegrate is attached to the unit with brackets which can be cut or pried off.
2. Remove the damper assembly. This includes the damper blade, handle and any linkage. Two 3" liners must be able to pass through the damper area.
3. Remove any firescreen or door assembly. This is usually accomplished with removal of a support rod on the inside of the fireplace frame.
4. Remove the metal ashtray, if appropriate, to allow the insert to sit flat within the fireplace. Be sure to reinstall any screws removed.

IMPORTANT:

BEFORE STARTING THIS INSTALLATION, MAKE SURE THAT A GAS LINE CAN BE INSTALLED OR IS INSTALLED TO THE FIRE-BOX. THIS SHOULD ONLY BE DONE BY A QUALIFIED OR LICENSED PLUMBER OR GAS FITTER.

Installation

Follow the same installation procedural steps detailed on the preceding page for masonry fireplaces.

VERY IMPORTANT NOTICE:

THE USE OF AN EXISTING CHIMNEY AS AN AIR INTAKE IS NOT COVERED UNDER THE ANSI Z21.88-1999-CSA 2.33-M99 TEST METHODS AND RESULTING ITS/WHI PRODUCT CERTIFICATION. THE CODE AUTHORITY HAVING JURISDICTION MUST BE CONSULTED PRIOR TO PROCEEDING WITH THIS INSTALLATION METHOD.

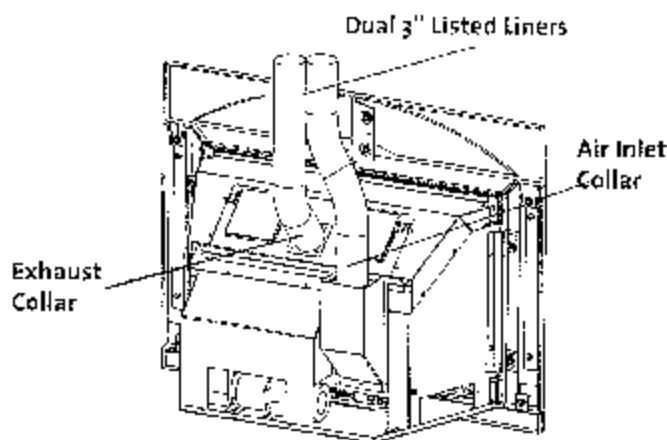
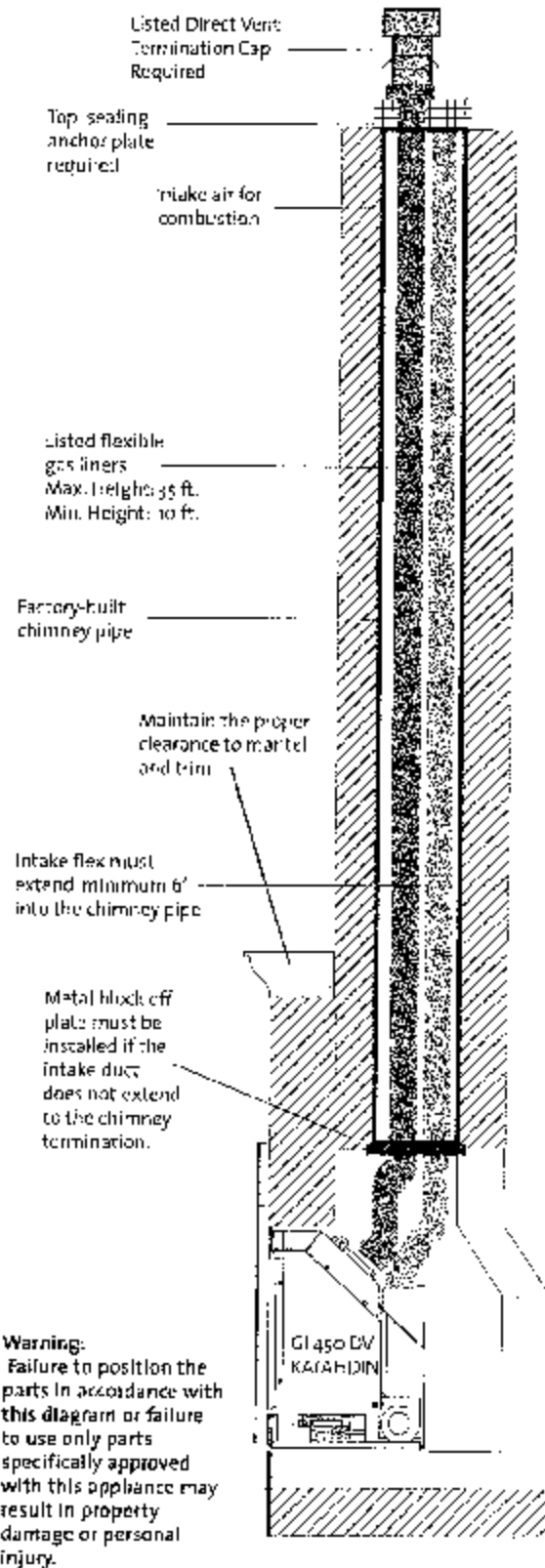

Figure 3. Duct collar locations.

Figure 4. Venting through prefabricated fireplace chimney.



Warning:
Failure to position the parts in accordance with this diagram or failure to use only parts specifically approved with this appliance may result in property damage or personal injury.

Clearance Requirements

The following clearances and hearth specifications are the minimum requirements for installing the G1450 Katahdin Insert into a solid fuel-burning fireplace. See figs. 5 through 8.

A combustible surface is anything that can burn (i.e. sheet rock, wallpaper, wood, fabrics etc.). These surfaces are not limited to those that are visible and also include materials that are behind non-combustibles.

If you are not sure of the combustible nature of a material, consult your local fire officials. Remember, "Fire Resistant" materials are considered combustible; they are difficult to ignite, but will burn. Also, "fire rated" sheet rock is considered combustible.

Always maintain the proper clearances to allow for the proper flow of ventilation air around the insert.

Fireplace Clearances

Measure clearances from the center and finished floor of the fireplace opening.

- A = 40" (1016 mm) to a Side Wall, (any combustible surface that extends more than 1 1/2" from the fireplace face)
- B = 22" (559 mm) to Side Trim that extends 1 1/2" or less from the fireplace face. If the side trim extends more than 1 1/2" from the fireplace opening then Side Wall clearance applies.
- C = 36" (867 mm) to Top Trim that extends 1 1/2" or less from the fireplace face.
- D = 38" (915 mm) to a Mantel that extends no more than 14 1/2" from the fireplace face.

NOTE: MANTEL AND TOP TRIM CLEARANCES ARE NOT AFFECTED BY THE USE OF THE 2" RISER BAR.

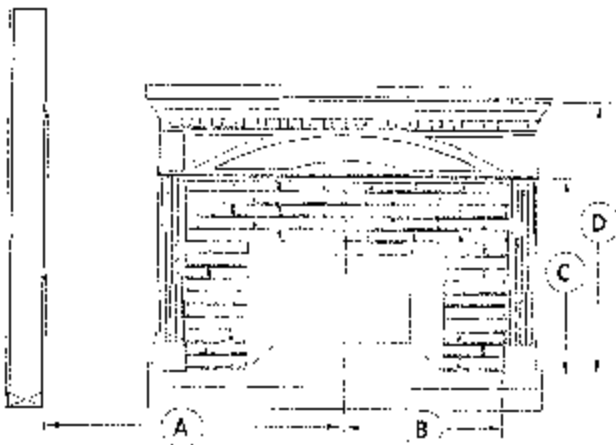

Figure 5. Fireplace clearances to combustible materials.

Hearth Requirements

Flush Hearth: requires a non-combustible hearth in front of the fireplace that extends a minimum of 18" (457mm) and is a minimum of 32" (813mm) wide.

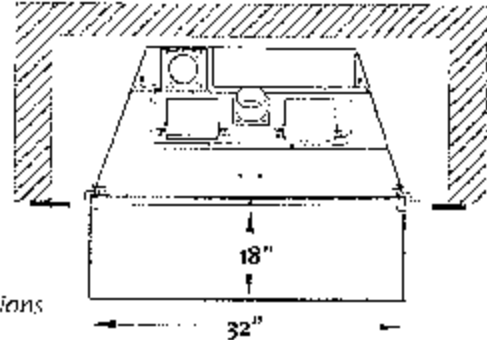

Figure 6. Flush hearth dimensions

Raised Hearth: A raised hearth that is at least 6" high requires a non-combustible hearth in front of the fireplace that extends a minimum of 12" (305mm) from the fireplace face and is a minimum of 32" (813mm) wide.

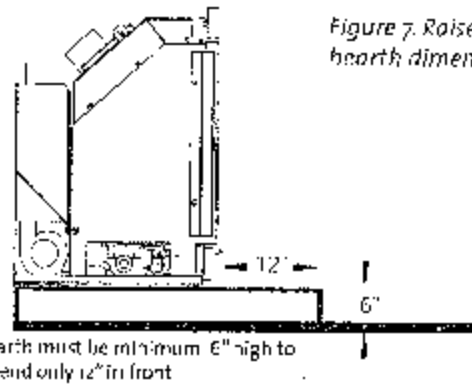

Figure 7. Raised hearth dimensions

NOTE: USE OF THE 2" RISER BAR DOES NOT EFFECT THE HEARTH REQUIREMENTS LISTED ABOVE.

Leg Leveler Brackets

See the Appendix on page 26 for information on the proper use of the Leg Leveler Brackets to raise the insert.

Clearance to Combustibles

When raising the firebox up to 2", mantel and hearth clearance remain unchanged from those specified above.

Raising the firebox higher than 2" will require that the clearance to mantel and trim be increased by 1":

- C = Hearth to Upper Trim - 37"
- D = Hearth to Mantel - 39"

Gas Conversion

The GI 250 Katahdin gas insert is shipped from the factory equipped to use NATURAL GAS. A conversion kit is included with the insert for installation to permit use of Propane fuel. The kit contains all the necessary components needed to ensure safe operation, including labeling that must be affixed to the insert.

WARNING:

THE CONVERSION KIT IS TO BE INSTALLED BY AN AUTHORIZED JÖTUL SERVICE TECHNICIAN IN ACCORDANCE WITH THE MANUFACTURER'S INSTRUCTION AND ALL CODES AND REQUIREMENTS OF THE AUTHORITY HAVING JURISDICTION. FAILURE TO FOLLOW THESE INSTRUCTIONS COULD RESULT IN SERIOUS INJURY OR PROPERTY DAMAGE. THE QUALIFIED AGENCY PERFORMING THIS WORK ASSUMES RESPONSIBILITY FOR THIS CONVERSION.

IN CANADA:

THE CONVERSION SHALL BE CARRIED OUT IN ACCORDANCE WITH THE REQUIREMENTS OF THE PROVINCIAL AUTHORITIES HAVING JURISDICTION AND IN ACCORDANCE WITH THE REQUIREMENTS OF THE CAN-1-B149.1 AND .2 INSTALLATION CODE.

CET EQUIPEMENT DE CONVERSION SERA INSTALLE PAR UNE AGENCE QUALIFIEE DE SERVICE CONFORMEMENT AUX INSTRUCTIONS DU FABRICANT ET TOUTES EXIGENCES ET CODES APPLICABLES DE L'AUTORISES AVOIR LA JURIDICTION. SI L'INFORMATION DANS CETTE INSTRUCTION N'EST PAS SUIVIE EXACTEMENT, UN FEY, EXPLOSION OU PRODUCTION DE PROTOXYDE DE CARBONE PEUT RESULTER BLESSURE PERSONNELLE DE VIE. L'AGENCE QUALIFIEE DE SERVICE EST ESPONSABLE DE L'INSTALLATION N'EST PAS PROPRE ET COMPLETE JUSQU'A L'OPERATION DE L'APPAREIL CONVERTI EST CHEQUE SUIVANT LES CRITERES ETABLIS DANS LES INSTRUCTIONS DE PROPRIETAIRE PROVISIONNEES AVEC L'EQUIPEMENT.

Tools Required:

1/4" Nut driver, 7/16" and 1/2" open end wrench or deep well socket, 4mm allen wrench, Torx T20 or slotted screwdriver.

Kit Contents:

- 1 regulator tower labeled for propane
- 3 regulator tower screws
- 1 burner orifice (#31 NG, #31 LPG)
- 3 pilot orifice (#30 for LPG, #31 for NG)
- Label A - applied to the base of the insert.
- Label B - to apply to the rating plate.

IMPORTANT:

Be sure to unplug the blower before proceeding with this conversion. The gas supply must be turned off and disconnected from the valve.

Conversion instructions are also included with the conversion kit.

Gas Conversion Procedure

1. Open the bottom grill assembly, release the two glass clips of the underside of the firebox.
2. Swing the bottom of the glass panel out and lift slightly. Remove the glass panel by lifting the glass frame over the brackets at the upper grill assembly. Note: It is NOT necessary to remove the Upper Grill assembly.
3. Lift out the andirons and remove the log set using care not to scratch or damage logs.
4. Remove burner tube: lift the rear of the tube and rotate slightly forward. Slide the tube to the right to disengage it from the burner orifice.
5. Once free of the orifice, continue to rotate forward so that screen and tube are easily removed. Lift out.
6. Change the main burner orifice. Using a 1/8" open end wrench or deep well socket, remove the burner orifice and replace with the appropriate orifice, supplied in the kit.
7. Adjust the air shutter on the burner tube to allow for the proper mixing of air and gas. See Figure 8.

the correct settings: Natural - 1/4" open

Propane - 1/4" open

Figure 8:

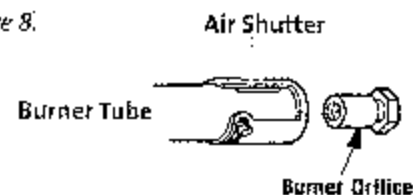

NOTE: AIR SHUTTER SHOULD NEVER BE LESS THAN 1/8" OPEN.

8. To change the pilot orifice: FROM WITHIN THE FIREBOX, PULL THE PILOT HOOD OFF THE PILOT ASSEMBLY. Using a 4mm allen wrench thread out the pilot orifice (counter clockwise). Replace with the appropriate orifice:

Tighten orifice into the base of the pilot assembly. Be sure the orifice is threaded tightly into the base. See fig. 9.

9. Replace pilot hood onto pilot assembly.

10. Replace the burner tube, BE SURE TO SLIDE TUBE TO THE LEFT COMPLETELY COVERING ORIFICE

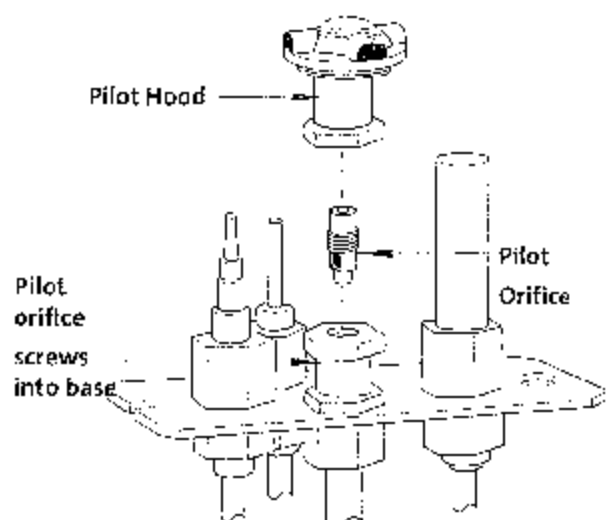

Figure 9. Pilot Assembly.

11. Open the bottom grill assembly to access the valve.
12. Change the variable regulator on the valve (Hi/Lo knob). Using a Torx t-20 screwdriver or small flat head screwdriver, remove the three specialty screws from the front of the valve regulator. See fig. 10.
13. Remove the regulator tower and gasket.
BE SURE TO REMOVE THE BLACK RUBBER GASKET FROM THE VALVE. See fig. 10.
14. Install the new variable regulator tower with the new rubber gasket. **Thoroughly** tighten new regulator to valve body.
15. Install the identification labels to the insert so that they can be seen by any person that may be servicing the insert. **APPLY LABEL B TO THE RATING PLATE IN THE SPACE PROVIDED.**
16. Reassemble the insert, apply gas to the system and check for gas leaks including all insert lines before and after the valve.

NEVER USE AN OPEN FLAME TO CHECK FOR GAS LEAKS.

IMPORTANT

Correct gas pressure is essential for efficient and safe operation of the Katahdin gas insert. It is important that the correct gas pressure be established at the time of the installation. For more details, see the Gas Pressure section of this manual on page 14.

ALWAYS REFER TO THE LIGHTING INSTRUCTIONS ON THE BACK COVER OF THIS MANUAL WHEN LIGHTING YOUR KATAHDIN.

BE SURE TO REMOVE THE BLACK RUBBER GASKET FROM THE VALVE.



Figure 10. Regulator Assembly.

Gas Supply Connection

The gas supply line connection is made to the valve on the left side of the unit facing the front. The gas supply line should be a minimum of 3/8" in diameter, or the appropriate size to provide sufficient gas pressure to the valve regardless of the input setting.

See fig. 11 and 12.

For your convenience the GI 450 DV Katahdin is shipped with a short piece of 3/8" iron and a 24" length of flexible gas line. Jotul recommends the use of the flexible gas line for ease of installation and service. However, for those areas where flexible gas lines are not permitted use of the 3/8" iron is recommended. See fig. 12.

The use of Flexible Gas Appliance Connectors is acceptable in many areas in the U.S., however, Canadian methods vary depending on local code.

ALL INSTALLATIONS MUST COMPLY WITH LOCAL CODE OR IN THE ABSENCE OF LOCAL CODE, MUST COMPLY WITH THE MOST RECENT EDITION OF THE NATIONAL FUEL GAS CODE ANSI Z223.1/NFPA 54 OR CAN-B149.

All codes require a gas shut-off valve (gas cock) union, to be installed in the supply line, and in the same room as the appliance. This allows for the disconnection of the insert for servicing and maintenance. See fig. 12.

T-handle gas cocks are required in Massachusetts in compliance with code 248CMR.

Figure 11. Valve inlet centerline.

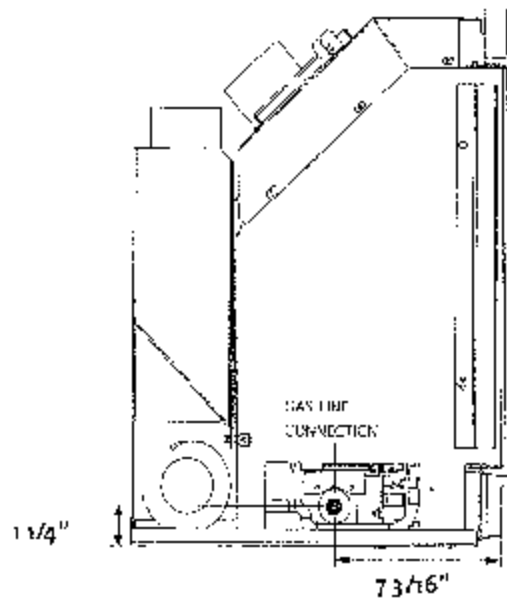

Secure all joints tightly using appropriate tools and sealing compounds (for propane units, be sure to use compounds that are propane resistant). Turn on gas supply and test for gas leaks using a soapy water solution. Never use an open flame to check for leaks.

Leak Test:

- Mix a 50-50 solution of water and dish soap.
- Light appliance - See lighting instructions on page 23 of this manual or on the rating plate.
- Brush or spray all joints and connections with the soapy water solution.
- If bubbles appear at any connection or seam or a gas odor is detected, immediately turn gas control knob to the OFF position.

Tighten or reconnect the leaking joint and retest for any gas leaks.

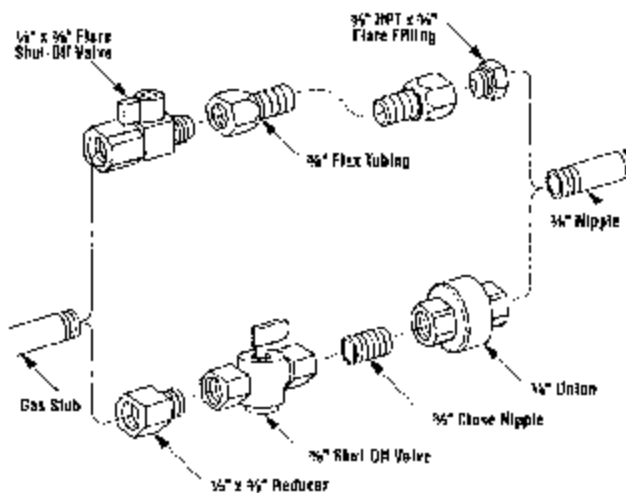

Figure 12 Gas connection components.

Gas Pressures

Correct gas pressure is essential for efficient and safe operation of the Katahdin gas insert. It is important that the correct pressure is established at the time of the installation.

Proper gas pressure provides a consistent flow of gas to the appliance and is instrumental in checking for gas leaks. The gas control valve on the insert is equipped with pressure test points for gauge connections. The gauge connections are located on the front of the valve under the On/Off/Pilot knob. See fig. 13.

IN / E for inlet or supply pressure (the amount of gas coming to the valve.)

OUT / A for manifold pressure (the amount of gas that is coming out of the valve to the burner.)

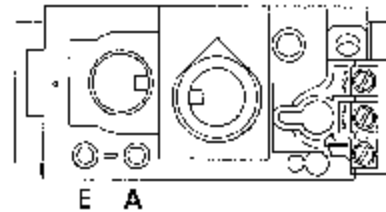

Figure 13. Pressure test points.

The appliance must be isolated from the gas supply line by closing its individual manual gas shut-off valve (gas cock) during any pressure testing of the gas supply piping system that is equal to or exceeds pressures of 1/2 psig (3.5 kPa).

NECESSARY INLET GAS PRESSURES (inches water column)

	MIN	MAX
NATURAL GAS	5.0 WC	13.5 WC
PROPANE	11.0 WC	13.5 WC

NECESSARY MANIFOLD PRESSURES (inches water column)

	MIN	MAX
NATURAL GAS	2.2 WC	3.5 WC
PROPANE	6.5 WC	10.0 WC

ALWAYS TEST PRESSURE WITH VALVE CONTROL KNOB SET ON HIGH.

Symptoms of incorrect gas pressure include:

Insufficient gas pressure:

- Small pilot flame which can result in insufficient millivolts.
- Little variation in flame picture between HI and LO settings.
- Insufficient gas to support more than one appliance causing nuisance outages or gas surges.

Excessive gas pressure:

- Permanent damage to valve causing complete appliance shut down.
- Too large a pilot flame resulting in over heating of the power generator causing shut down.
- Sooting due to impingement and/or incorrect fuel to air mix.

High Altitude Adjustment

When installing GI 450 Katahdin insert at high altitude (above 2000'), it is necessary to compensate for the thinner air (less volume of air per cubic foot). Higher altitudes affect the atmospheric pressure and heat value of gaseous fuels. The lower oxygen content in the air and the lower gas viscosity require the use of a different orifice to achieve efficient, clean combustion at the burner tube.

In the U.S.

THE DERATING KIT MUST BE INSTALLED BY AN AUTHORIZED SERVICE TECHNICIAN IN ACCORDANCE WITH THE MANUFACTURER'S INSTRUCTIONS AND ALL CODES AND REQUIREMENTS OF THE AUTHORITY HAVING JURISDICTION. THE INFORMATION STICKER MUST BE FILLED OUT BY THE INSTALLER AND ADHERED TO THE APPLIANCE AT THE TIME OF THE CONVERSION. THE QUALIFIED SERVICE AGENCY PERFORMING THIS WORK ASSUMES RESPONSIBILITY FOR THIS DERATING.

In Canada

This unit has been tested for installation at high altitudes in accordance with Canadian test standard CAN/CGA-7.17. THE DERATING SHALL BE CARRIED OUT IN ACCORDANCE WITH THE REQUIREMENTS OF THE PROVINCIAL AUTHORITIES HAVING JURISDICTION AND IN ACCORDANCE WITH THE REQUIREMENTS OF THE CAN-B-149.1 AND .2 INSTALLATION CODE.

HIGH ALTITUDE INSTALLATIONS:

2000 ft. to 4500 ft. installations (or 610m - 1370m)
See Table 1.

For high altitude installations consult the local gas distributor or the authority having jurisdiction for proper rating methods. If the installer must convert the unit to adjust for varying altitudes, the information label must be completed by the installer and affixed to the appliance at the time of the conversion. See fig. 14.

Derating procedure

1. To derate this unit, install the appropriate orifice per the High Altitude Chart.
2. Remove the two 1/2" hex head screws that hold the burner tube/log support to the bottom of the insert.
3. Remove the burner tube/log support to expose the main burner orifice.
4. Remove the orifice and replace with the appropriate one from the high altitude kit.
5. Be sure to attach the high altitude conversion sticker provided with the kit to the rating plate on the appliance. See figure 14.
6. It may be necessary to adjust the air shutter on the burner tube. See the AIR SHUTTER/FLAME APPEARANCE section of this manual for more detail.

GAS TYPE	ORIFICE SIZE	ELEVATION	JOTUL PART NO.
NATURAL GAS	#31	0 - 2000' (0 - 610m)	045026
PROPANE	#51	0 - 2000' (0 - 610m)	045027
NATURAL GAS	#32	2001' - 4500' (611 - 1370m)	045024
PROPANE	#52	2001' - 4500' (611 - 1370m)	045025

Table 1. High Altitude Orifice Chart.

THIS APPLIANCE HAS BEEN CONVERTED FOR USE	
AT AN ALTITUDE OF _____	
Orifice Size: _____	Manifold Press: _____
Input, BTU/Hr: _____	Fuel Type: _____
Date of Conversion: _____ / _____ / _____	

Figure 14. High Altitude Conversion Notice Label

Flame Adjustment / Air Shutter

THE KATAHDIN GAS INSERT IS SHIPPED FROM THE FACTORY EQUIPPED FOR USE WITH NATURAL GAS. WHEN USING PROPANE, IT WILL BE NECESSARY TO ADJUST THE AIR SHUTTER ON THE BURNER TUBE TO ACHIEVE THE PROPER GAS TO AIR MIX. See fig. 15.

WARNING:

AIR SHUTTER ADJUSTMENTS SHOULD ONLY BE PERFORMED BY A QUALIFIED PROFESSIONAL SERVICE TECHNICIAN.

The air shutter adjustment can also help achieve the desired flame appearance. Generally, flame appearance is a matter of preference, however most consumers enjoy the warm, yellowish flame.

Closing the Air Shutter - Insufficient combustion air will result in very long yellow flames that can promote soot. Sooting produces black deposits on the logs, on the inside walls of the appliance, and potentially on the exterior termination cap.

Sooting is caused by incomplete combustion in the flames and lack of combustion air entering the air shutter opening.

Opening the air shutter - will generate a flame that is blue and transparent, or an "anemic" flame. This flame is generally more efficient, but not very attractive.

Jotul recommends the following settings for the Katahdin gas insert:

Propane: 1/4" open

Natural Gas: 1/4" open

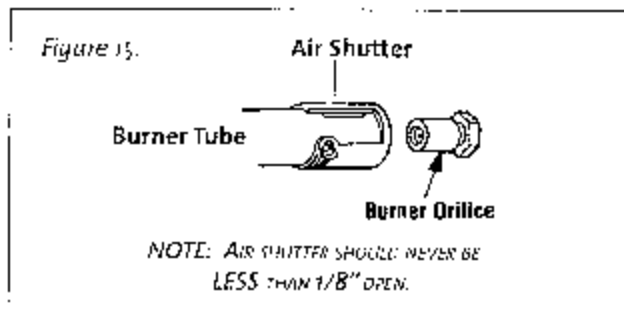

REMEMBER: Run the insert for a minimum of 15 to 20 minutes for an accurate representation of the flame appearance. This should be done before and between any air shutter adjustments.

To adjust the air shutter

1. Remove the burner tube and using a phillips head screwdriver loosen the screw at the air shutter and adjust accordingly.
2. Be sure to retighten the screw that holds the air shutter setting.
3. Reassemble the insert including glass assembly. Allow insert to burn 30 minutes on the HIGH setting, observing the flame continuously.
4. If the flame appears weak, slow, or sooty, repeat the process described above until the flame is as desired.

Installing the Log Set

NOTE: Install the optional Antique Brick Panels before installing the Log Set.

The Katahdin is equipped with a three piece log set packaged in bubble wrap inside the firebox. The log set must be removed from the packaging and arranged in the unit prior to start up of the gas insert. Protect your hands by wearing gloves to prevent skin irritation from the ceramic fibers.

1. Unwrap each log and set on floor near unit.
2. Lift out and iron.
3. Place rear log over the rear log pins in the rear of the firebox. The rear log should be installed with the tapered end of the log on the right.

Figure 16. Log identification.

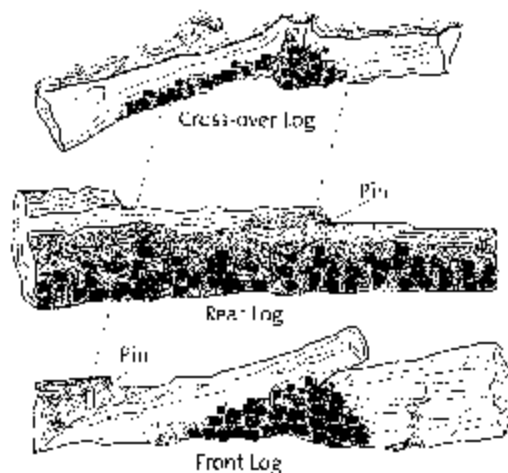

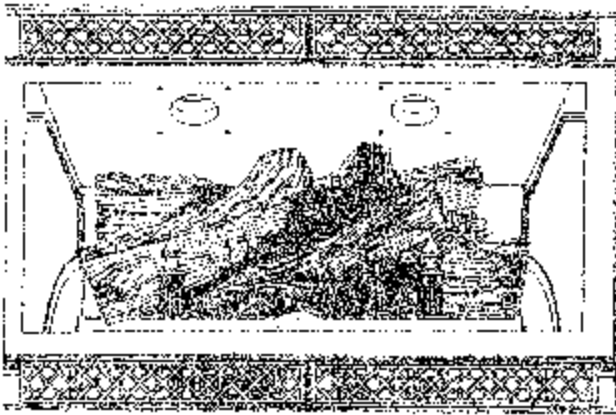

Figure 17. Completed log set assembly

4. Place the front log on the single log pin so that the left end of the log rests on the log support and the andiron holder directly above the air shutter.
5. Place the cross-over log on the two remaining pins- top right to the rear log, bottom left on the front log. See fig. 17.
6. Install the embers: the insert is shipped with a package of ember stones. Spread them evenly across the burner tube screen. It is best to equally space these embers for optimum flame appearance. **NOTE: YOU DO NOT NEED TO USE ALL OF THE EMBER STONES.**
7. Replace the andiron set, center in the firebox over the andiron support.

THE CERAMIC FIBER LOGS AND EMBER STONES CAN IRRITATE YOUR SKIN. IF THIS HAPPENS, GENTLY WASH HANDS WITH WARM, SOAPY WATER.

Blower Operation

The G1450 DV Katahdin is equipped with a 125 cfm heat-activated blower. A ten foot power cord is installed in the rear of the valve compartment under the firebox.

Open the Lower Grill and fully unwrap the power cord. The cord can exit either the right or left side of the insert. Be sure to pull all slack out of the power cord to prevent contact with the bottom of the firebox.

The is equipped with a three-prong (grounding) plug for protection against shock hazard and should be plugged directly into a properly grounded three-prong receptacle. **DO NOT CUT OR REMOVE THE GROUNDING PRONG FROM THE PLUG.**

The blower must be electrically grounded in accordance with local codes or, in the absence of local codes, with the current NFPA 70- National Electrical Code or CSA C22.1-Canadian Code.

The blower is controlled by a heat activated switch (snapstat) that will function only if the blower control switch is in the AUTO setting. Once the firebox heats after the burner has been operating for a short time, the blower will start on either the HI or LOW speed. In AUTO mode, the blower will continue to operate after the burner is turned off, until the snapstat cools. See fig. 18.

If blower operation is not desired, place the control switch in the OFF position to bypass the snapstat function.

NOTE:

ALWAYS UNPLUG THE BLOWER WHEN SERVICING THE APPLIANCE.

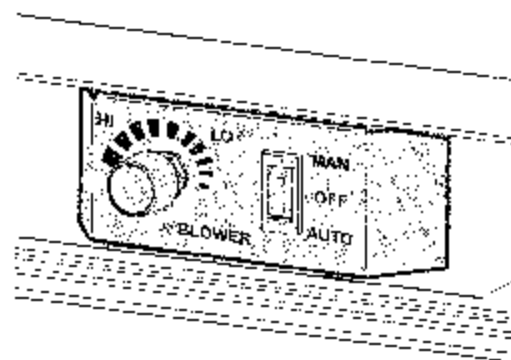

Figure 18. Blower Controls

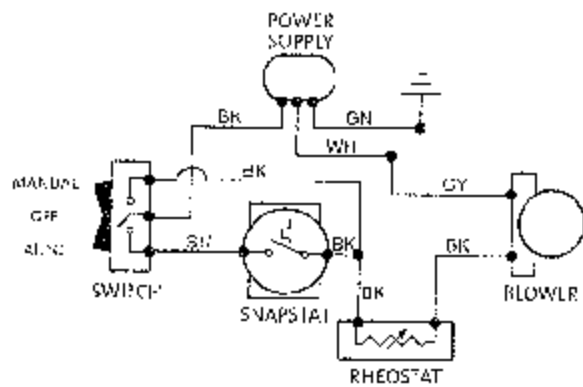

Figure 19. Blower Wiring Diagram - G1450 Katahdin

Wall Thermostat

Use only a 750 millivolt DC two-wire circuit thermostat. The thermostat should be placed in the same room as the heater, typically 5' off the floor. Avoid drafty areas or any area that may affect the accuracy of the thermostat.

The thermostat should be connected to the Katahdin using a minimum of 16 gauge wire with a maximum length of 35 feet of wire.

Connect the two thermostat wire leads to the two lower terminals on the terminal block located to the right of the ON/OFF/T-STAT switch. Do not overtighten the connections. IT IS NOT NECESSARY TO DISCONNECT ANY OTHER WIRES. See Figure 20.

For the thermostat to function, the ON/OFF/T-STAT switch must be in the T-STAT position, and the pilot light must be running, as it is the power source for the thermostat.

At the thermostat, the two wires should be connected to the two connections screws on the thermostat base plate per the manufacturer's instructions.

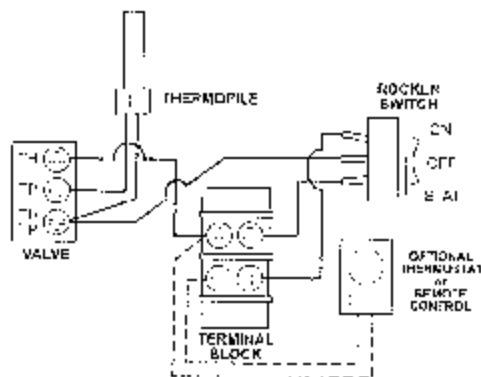

Figure 20. Wiring diagram / G1450 DV Katahdin

Optional Remote Control #129706

The optional Jøtul remote can be installed on the Katahdin gas insert. Using the wires supplied with the remote, it is best to wire the remote directly to the gas control valve of the insert.

Connect one receiver lead to the terminal labeled TH. Connect the other receiver lead to the terminal labeled TH/TP. DO NOT DISCONNECT ANY OTHER WIRES FROM THE VALVE, AND DO NOT OVERTIGHTEN TERMINAL SCREWS.

Jøtul recommends the use of the optional Remote Receiver Heat Shield (# 129708) to protect the receiver under the firebox. The best location for the receiver is just below the air intake port toward the back of the unit.

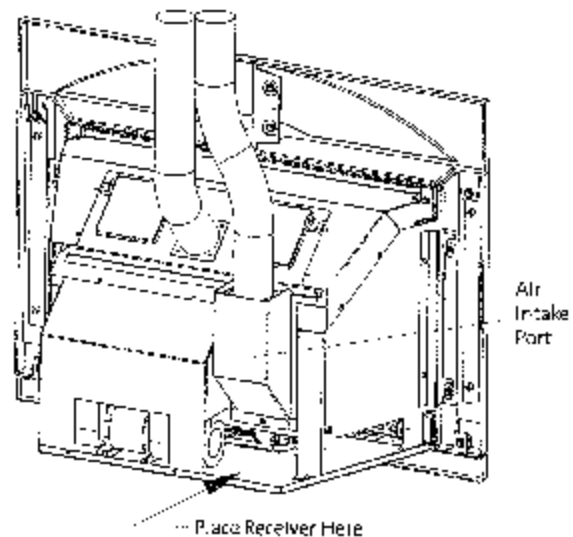

Figure 21. Remote Receiver position.

CAUTION:

LABEL ALL WIRES PRIOR TO DISCONNECTION WHEN SERVICING THE CONTROLS. WIRING ERRORS CAN CAUSE IMPROPER AND DANGEROUS OPERATION. ALWAYS VERIFY PROPER OPERATION AFTER SERVICING THE APPLIANCE.

ATTENTION:

AU MOMENT DE L'ENTRETIEN DES COMMANDES, ÉTIQUÉTEZ TOUS LES FILS AVANT LE DÉBRANCHEMENT. DES ERREURS DE CABLAGE PEUVENT ENTRAÎNER UN FONCTIONNEMENT INADEQUAT ET DANGEREUX.

Surround Panel Installation

Complete the venting and gas line installation before installation of the surround and riser bar.

All Surround Panel fasteners are already installed in the appropriate locations. Simply remove and use them to attach the panels together in the same locations. A 10 mm wrench will be required.

RISER BAR: The 2" riser bar is used in conjunction with the standard surround, and is only needed in the event that the fireplace opening is between 27 1/2" and 29 1/2" high. The riser bar can be used in any installation if desired. See fig. 22.

Start with the insert slightly pulled out of the fireplace.

1. If the riser bar is to be used the insert must be lifted 2" off the floor of the fireplace to allow for the riser bar to fill the space below the bottom grill assembly. Exception: in raise fireplace installations the riser bar may extend toward the hearth. See fig. 22.
2. This can be done through the use of the four leveling legs that are included with the unit. One leveling leg is threaded through the floor in each corner of the fireplace.
3. Any other non-combustible material can be used to lift the unit the necessary 2" for the riser bar.

NOTE: DUE TO THE WEIGHT OF THE SURROUND AND RISER BAR IT MAY BE NECESSARY TO UTILIZE THE STABILIZER BAR THAT IS SHIPPED WITH THE UNIT. THIS STABILIZER ATTACHES TO THE OUTSIDE OF THE FIREBOX AND WILL BRACE THE UNIT AGAINST THE FIREPLACE LINTEL PREVENTING THE UNIT FROM LEANING FORWARD. See figs. 22 and 22A.

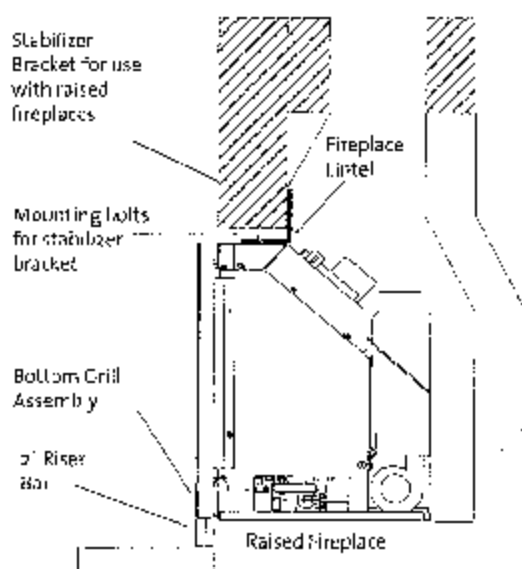

Figure 22. Installing the Stabilizer Bar.

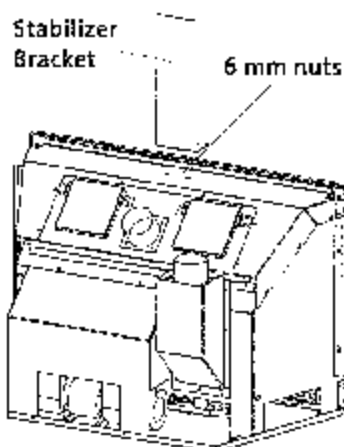

Figure 22A. Mount the stabilizer bar using the two 6mm nuts installed on the top of the unit.

4. Lay the four surround panels on the floor backside up. Using two bolts and washers attach the right and left upper sections (breastplates) together. See fig. 23.
5. Attach the left and right leg sections to the breastplate assembly using a bolt and washer on each side. See fig. 24.
6. Four mounting tabs are attached to the back of the surround panels at the factory. Be sure all four tabs are in place and secure. See fig. 25.
7. Stand the assembled surround up and gently lift to the unit. Align the mounting holes on the sides of the insert with the mounting tabs on the surround. See fig. 25.

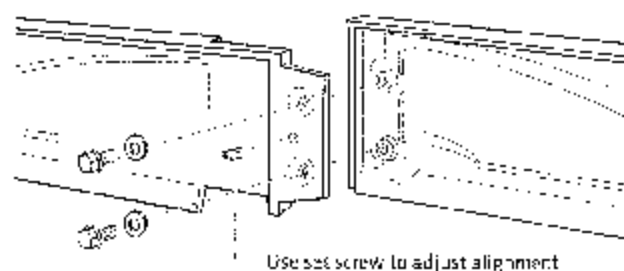

Figure 23. Attach Surround Breastplates

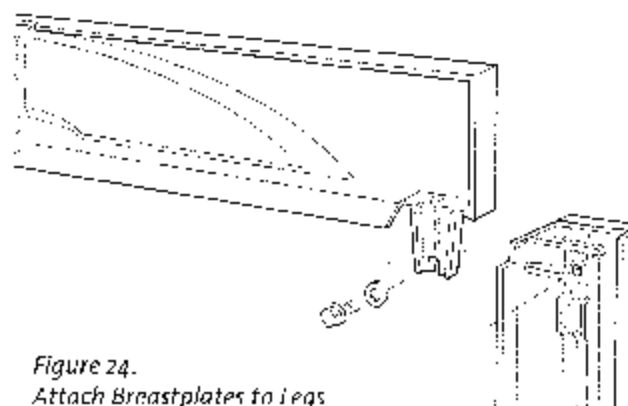

Figure 24. Attach Breastplates to legs

- Slide the surround down into the mounting holes. Be sure all four mounting tabs engage securely with the adjacent bracket holes. See fig. 26.
- Secure the two sections of the riser bar together with a washer and bolt and slide the assembled riser bar under the bottom grill assembly on the unit. Attach the Riser Bar to each leg panel with a bolt and washer as shown in fig. 25.

Note: the riser bar is not used for support of the insert- if more space is needed for the riser bar, raise the unit using the front levelling legs. See figure 27.

- Gently and slowly push the unit and surround back into the fireplace. This is best done by pushing the front outside edges of the glass frame. **Reminder:** Be sure to inspect the gas line and blower cord to make sure they are not crushed when the unit is in its final location.

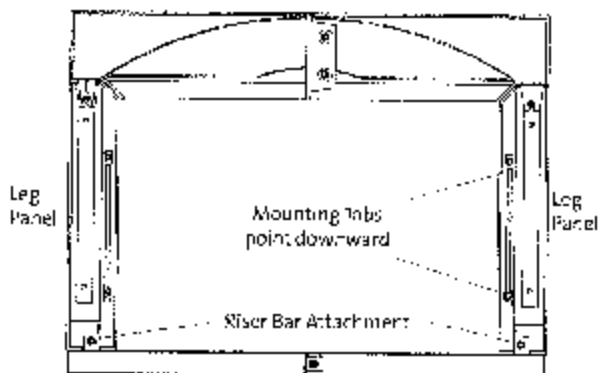

Figure 25. Surround mounting tab locations.



Figure 26. Surround engagement with firebox.

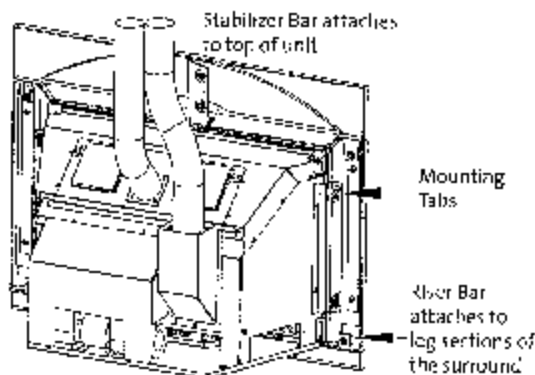

Figure 27. Riser Bar installation.

Checking the System

- PURGING THE GAS LINE:** When lighting the appliance for the first time it will take a few moments to clear the gas line of air. Once this purge is complete, the appliance will operate as described in the lighting instructions located on the insert's rating plate and back cover of this manual. All subsequent lightings of the insert will not require such purging of the gas line.
- PILOT FLAME:** The pilot flame should be steady, not lifting or floating. The flame should be blue in color around the pilot hood, with traces of yellow toward the outer edges. It is imperative that the pilot flame engulf the top 3/8" of the thermopile (power generator) and the top 1/8" of the quick drop over thermocouple. The pilot flame should project out of the pilot hood 1" at all three ports. See Figure 28.

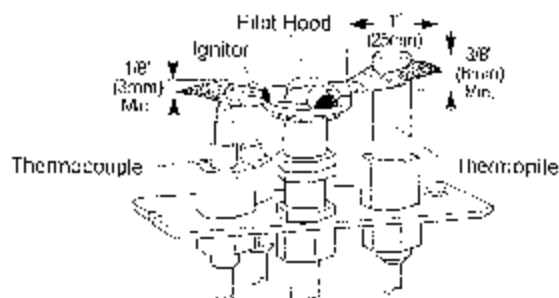

Figure 28. Correct Pilot flame appearance.

- BURNER ADJUSTMENT:** The burner is equipped with a variable gas control valve. This valve provides easy adjustment of the flame height appearance and heat output. To adjust the flame between the HI and LO setting, rotate the HI/LO knob, located in the center of the valve face. Flame height will adjust approximately 1.0" to 1.5" between the HI and LO settings.

NO SMOKE OR SOOT SHOULD BE PRESENT. CHECK LOG PLACEMENT IF ANY SOOT OR SMOKE IS APPARENT. IF SOOT OR SMOKE PERSIST, THE AIR SHUTTER MAY REQUIRE ADJUSTMENT.

CAUTION:

DO NOT ATTEMPT TO ALTER THE FLAME APPEARANCE BY POSITIONING THE GAS VALVE IN ANY OTHER POSITION OTHER THAN THE FULL "ON" POSITION.

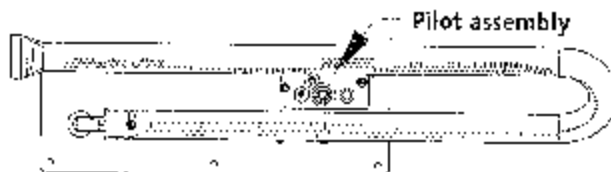

Figure 29. Pilot assembly location.

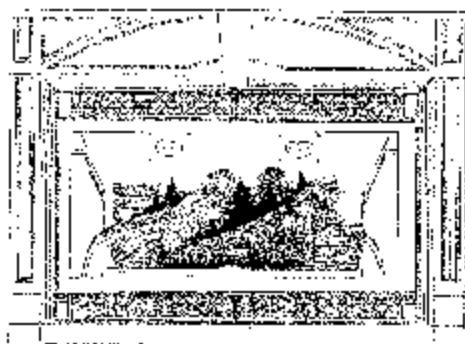

Figure 30. Normal flame pattern.

Fireplace Operation

1. This appliance is equipped with an On/Off/T-stat rocker switch to control burner functions. Use the T-stat position for use with an optional wall-mounted thermostat. Separate switches are provided for the multifunction forced air blower kit.
2. When lit for the first time, the Kalahdin will emit an odor for several hours. This odor is the burn-off by-products of external paints and lubricants used in the manufacturing process. Open a nearby window to provide fresh air and alleviate this temporary condition.
3. Condensation may occur on the glass upon each lighting of the appliance. This "fog" will disappear as the appliance temperature increases.
4. Keep the controls and the area under the appliance free of debris; vacuum this area frequently. Always keep the appliance area clear and free from combustible materials, gasoline and other flammable liquids. ALWAYS be sure the insert is cold and NO hot embers or sparks are present before using a vacuum cleaner.
5. Remember, this appliance has a continuous burning pilot flame. Exercise caution when using products with combustible vapors.
6. **CAUTION: DO NOT OPERATE THIS APPLIANCE WITH THE GLASS REMOVED, CRACKED OR BROKEN.** REPLACEMENT OF THE GLASS SHOULD BE DONE BY A LICENSED OR QUALIFIED SERVICE PERSON. USE ONLY REPLACEMENT GLASS PROVIDED BY YOUR AUTHORIZED JØTUL DEALER. NEVER USE ANY SUBSTITUTE MATERIALS.

WARNING:

OBSERVE CAUTION NEAR THE GLASS. THE GLASS PANEL MAY SHATTER UNEXPECTEDLY IF STRUCK WITH AN OBJECT. ALWAYS HANDLE THE GLASS PANEL WITH CARE.

7. Clean the glass only when necessary. Wipe surface with a clean, dampened, soft cloth. Follow with a dry, soft towel as desired. Take care not to scratch the glass surface.

WARNING:

DO NOT USE ABRASIVE CLEANERS ON THE GLASS. NEVER CLEAN THE GLASS WHEN IT IS HOT.

Maintenance

The Kalahdin gas insert and its venting system should be inspected before use and at least annually by a qualified service technician.

IMPORTANT:

ALWAYS TURN OFF THE GAS SUPPLY TO THE INSERT AND UNPLUG THE FORCED AIR BLOWER BEFORE ANY SERVICE WORK IS PERFORMED ON THE INSERT.

General cleaning: The firebox should be vacuumed out annually to remove any surface build up. Be sure to vacuum or wipe off the pilot assembly and burner orifice and burner tube. Also, when vacuuming the log set, be sure to handle it carefully as it is very fragile.

Gasket inspection: It is important that the glass gasket be inspected at least annually. Examine the rope gasket for signs of deterioration and make sure the gasket has a positive seal. This is important to prevent combustion gases from escaping into the room. Replace the gasket if necessary, refer to the replacement parts list on page 23.

To remove the glass panel or glass gasket:

1. Open the bottom grill assembly
2. Release the glass clips on either side of the bottom of the firebox.
3. Swing the bottom of the glass frame out and lift slightly.
4. Remove the glass panel by lifting the glass frame over the brackets at the upper grill assembly. **NOTE: IT IS NOT NECESSARY TO REMOVE THE UPPER GRILL ASSEMBLY.**
5. Lay the assembly on a flat surface and lift the metal tabs that secure the glass panel to the frame.
6. Install the new glass panel and gasket in the glass frame and secure with metal tabs. Do not over tighten tabs as this could break the glass.

ALWAYS USE JØTUL AUTHORIZED PARTS. NEVER SUBSTITUTE ANY OTHER PARTS.

Always replace any damaged or broken parts on the Katahdin with JØTUL AUTHORIZED PARTS ONLY. These are available through your Authorized Jøtul dealer. Never use any substitute parts on your Katahdin gas insert.

The Katahdin and its venting system should be inspected annually or semi-annually by a qualified service person or agency.

With proper care and maintenance, your appliance will provide you with years of enjoyment. If you experience any problem or inconsistency with your Jøtul Katahdin gas insert, contact your Jøtul Authorized Dealer for assistance.

To expedite the proper service for your appliance the following information will help your dealer determine what you will need for parts and service.

RETAIN THIS MANUAL FOR REFERENCE AND MAKE IT AVAILABLE TO ANYONE USING OR SERVICING THE INSERT.

MODEL NAME: Jøtul G. 450 DV Katahdin Gas Insert

SERIAL NUMBER: _____

DATE OF PURCHASE: _____

AUTHORIZED DEALER: _____

NAME OF INSTALLER: _____

TYPE OF FUEL: _____

FUEL CONVERSION: NO _____ YES _____

NOTES: _____

SERVICE LOG:

First Year

Name of Technician _____

Company Name _____

Date of service _____

Work Performed _____

SERVICE LOG:

Second Year

Name of Technician _____

Company Name _____

Date of service _____

Work Performed _____

SERVICE LOG:

Third Year

Name of Technician _____

Company Name _____

Date of service _____

Work Performed _____

Jøtul GI 450 DV Katahdin

the part list on page 23 includes many parts not shown in this illustration.

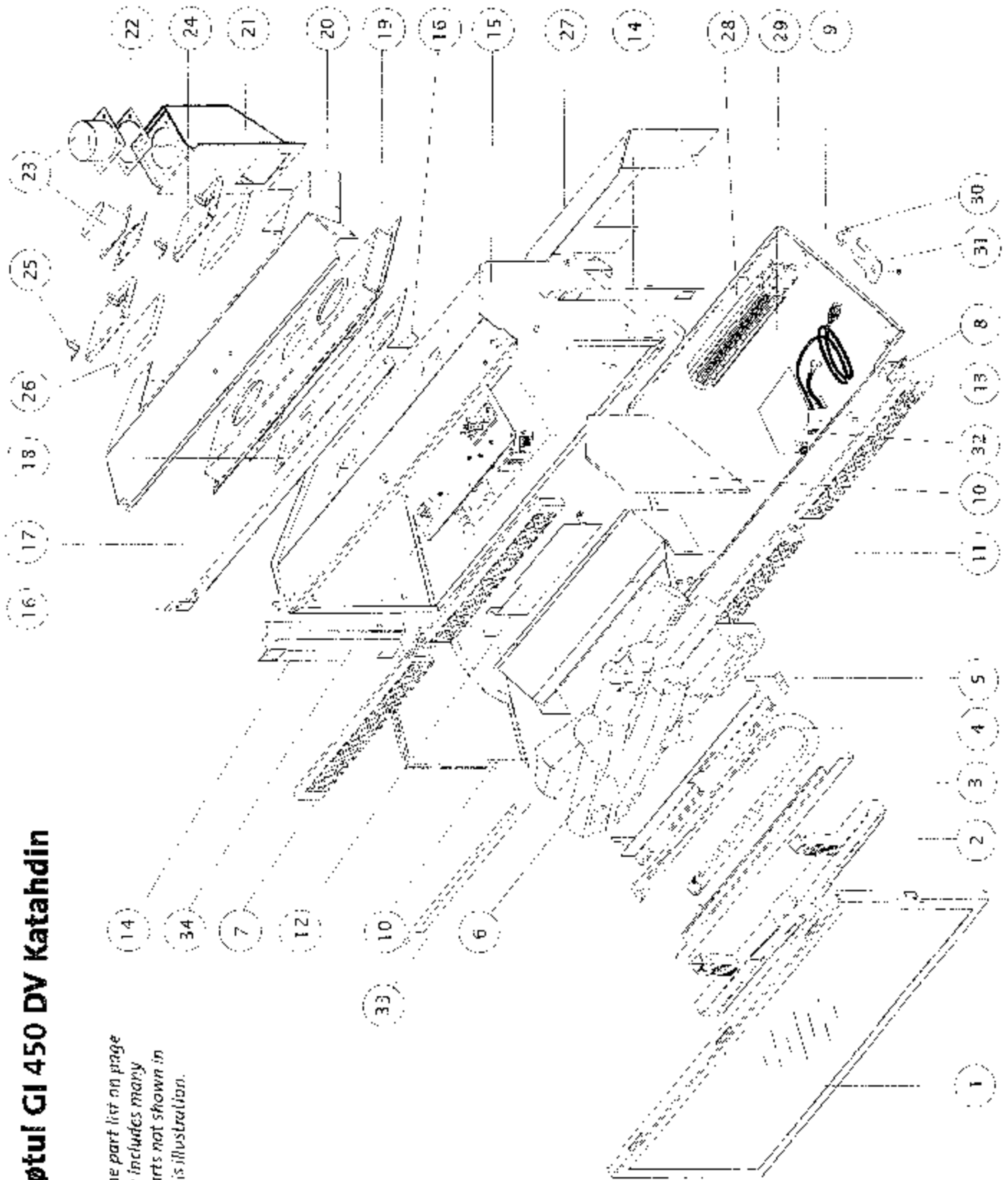

Figure 31. Illustrated Parts Breakdown - GI 450 DV Katahdin / Rev. 23/02/09

GI 450 DV Katahdin Parts List

1	Class Assembly, Complete	154902	34	Spud Plate Assembly, NG	154901
	Class Panel	129662		Spud Gasket	129669
	Class Frame	12961792		Valve - NG	3902159
	Class Panel w/ gasket	154986		Valve - LP	3902160
	Glass Gasket - 8ft.	129124		Pilot Gasket	129116
	Glass Latch	129135		Pilot Assembly (NG - Footco)	129171
2	Andiron - Blue Black	10393877		Pilot Orifice NG #51	129472
3	Andiron Holder	12968292		Pilot Orifice LP #30	129473
4	Burner Kit	154994		Orifice Holder	129668
	Burner Tube	129660		Nut - Orifice Holder	129152
5	Burner Tube Holder	12968392		Brass Elbow 3/8 NTP to 3/16	129229
6	Log Set	155379		Main Gas Line, w/ nut & ferruls	154372
	Front Log	120626		Main Burner Orifice NG #31	045026
	Rear Log	120627		Main Burner Orifice LP #51	045027
	Cross-over Log	120628		Ignitor Button	3602573
7	Upper Grill, left - Matte Black	10394492		On/Off Extension Knob	129729
	Blue-Black	10394427		High/Low Extension Knob	129730
	Jotul Iron	10394485		Terminal Block	129154
	Upper Grill, right - Matte Black	10394592		Thermocouple - Standard	129766
	Blue-Black	10394527		Thermopile	3034527
	Jotul Iron	10394585		Electrode w/ wire	129765
8	Bottom Grill Assembly Hinge	901043		On/Off/Tstat Switch	129153
9	Bottom Pan	220532		Embers	129123
10	Burn Plate, left	10395077		2 1/2" Supply Flex	129707
	Burn Plate, right	10393927		7" Supply Nipple	129728
11	Log Support	129621		Stabilizer Bracket	129714
12	Air Deflector - rear wall	129676		Leg Leveler Bracket, Right (2)	224440
13	Bottom Grill left - Matte Black	10394692		Leg Leveler Bracket, Left (2)	222730
	Blue-Black	10394627			
	Jotul Iron	10394685			
	Bottom Grill right - Matte Black	10394792			
	Blue-Black	10394727			
	Jotul Iron	10394685			
14	Surround Hanger - left	12969792			
	Surround Hanger - right	12962592			
15	Firebox	222510			
16	Top Grill Mount - left	12963252			
	Top Grill Mount - right	12963192			
17	Glass Frame Hanger	12966192			
18	Heat Exchanger Gasket	129673			
19	Heat Exchanger	129624			
20	Top Shroud	12964192			
21	Air Intake Manifold	129618			
22	3" Intake/Exhaust Gasket	129677			
23	3" Intake/Exhaust Collar	129622			
24	Relief Door	12969692			
25	Relief Door Guide	12949992			
26	Relief Door Gasket	129673			
27	Blower Shroud	12963092			
28	Blower, Rplcmnt / Variable Speed	222072			
29	Blower Switch Box, Complete - M3	156849			
	Blower Switch Box, Complete - JI	156856			
30	Blower Snapstat (140-120 deg F)	220437			
31	Snapstat Bracket	120608			
32	Blower Control Switch	220703			
33	Exhaust Baffle	220712			

HARDWARE

1/4" hex head sheet metal screws	117917
M8 X 40 leveling col. (4)	118047
M6 X 12 bolt (Surround, Grills)	117130
M6 X 10 set screw (Breast Plate)	117720
M5 X 10 bolt (Hinge bolts)	117970
MG washer	120024
M6 flange nut	117968
Star washer	117658
Hanger Tab	129680

ACCESSORIES

Fuel Conversion Kit - to Propane	154903
Fuel Conversion Kit - to Natural Gas	154928
Remote Control Kit	129706
Remote Receiver Heat Shield	129708
Antique Brick Panel Kit	155367
Wide Surround Kit - Matte Black	155323
Blue-Black	155324
Jotul Iron	155554

SURROUND PARTS

	Matte Black	Blue-Black	Jotul Iron
1 Breast Plate, Left	10394092	10394027	10394085
2 Breast Plate, Right	10394192	10394127	10394085
3 Leg, Left	10394292	10394227	10394285
4 Leg, Right	10394392	10394327	10394385
5 Riser Bar, Left	10394492	10394427	10394485
6 Riser Bar, Right	10394592	10394527	10394485

ALWAYS USE REPLACEMENT PARTS
PROVIDED BY AN AUTHORIZED JOTUL DEALER ONLY.

Antique Brick Panel Kit #155367

CAUTION!

THE BRICK PANELS AND LOG PARTS ARE EXTREMELY FRAGILE. USE BOTH HANDS TO SUPPORT EACH PIECE AS YOU HANDLE THEM.

Tools Required: 10 mm socket wrench
Safety glasses and gloves

Kit Contents

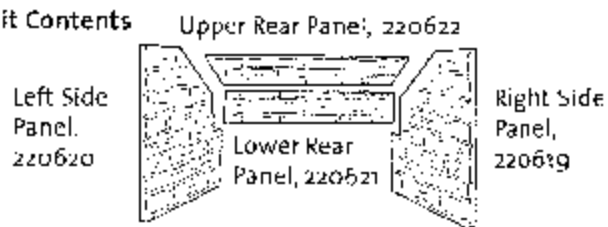

Installation Instructions

1. Remove the Glass Frame. Disengage the two compression latches located in the control compartment and lift the frame off of the tabs at the top of the firebox.
2. Remove the Andirons and Logset. These parts are not fastened. Simply lift them out of the firebox.
3. Remove the Cast Iron Side Panels. Use a 10mm socket wrench to remove the retainer brackets located at the rear corner of each panel. These panels will not be reinstalled, however, you must replace the two 6 mm bolts to plug the holes.
4. Install the Right Side Panel. Position the panel bottom first against the firebox wall and slide it forward against the firebox front.
5. Install the Lower Rear Panel. Orient the panel so that the beveled edge is on top and the mortar joints align with those on the side panel. Engage the bottom edge with the cutout in the side panel.
6. Install the Left Side Panel. Lift the lower panel up enough to allow the side panel to clear it. Be sure to push the side forward, up against the firebox front.
7. Install the Upper Rear Panel. This will be a snug fit. Set the panel up high and then carefully lower it to seat its bottom edge against the top of the other rear panel. The side panels will hold it in place.
8. Reinstall the Logset and Andirons. Refer to the Owner's Manual if necessary.
9. Replace the Glass Frame. First, engage the top of the frame with the retainer tabs at the top of the firebox. Seal the frame against the firebox and pull the latches forward to engage with the slots in the frame bottom.

Figure 32. Brick Panel Identification

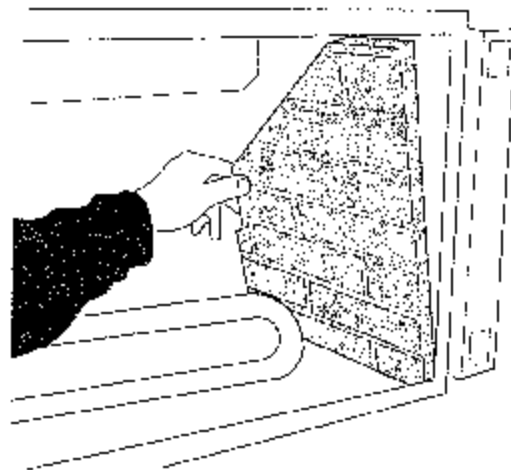

Figure 33. Install the Right Side Panel.

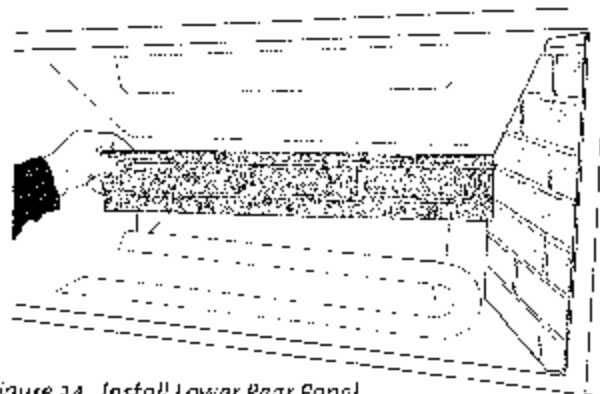

Figure 34. Install Lower Rear Panel.

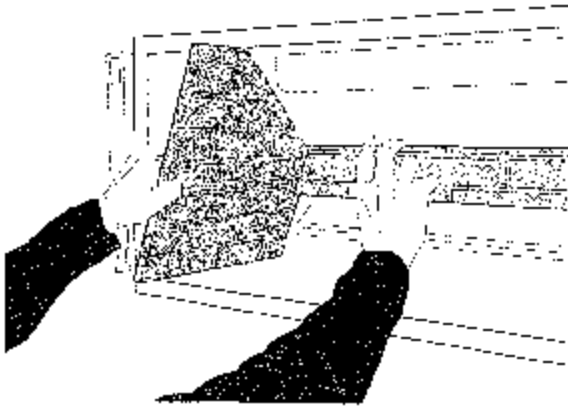

Figure 35. Install Left Side Panel.

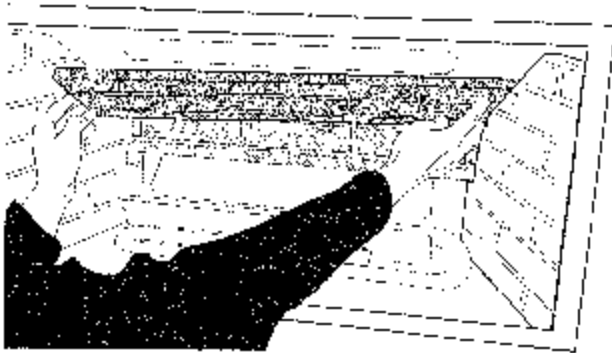

Figure 36. Install Upper Rear Panel.

Appendix

Leveler Bolts and Brackets

This feature enables greater installation flexibility beyond eliminating problems caused by irregularities in the hearth floor.

The leveling bolts may be extended from the mounting brackets no more than $1/2$ ".

The firebox may be further raised, in $1/2$ " increments, up to $2 1/2$ " more (max. 3" total) by adjusting the height of the leveling bolt mounting brackets.

Clearance to Combustibles

When raising the firebox up to 2", mantel and hearth clearance remain unchanged from those specified in the Operation Manual.

Raising the firebox higher than 2" will require that the clearance to mantel and trim be increased by 1":

- Hearth to Upper Trim - 37"
- Hearth to Mantel - 39"

Stabilizer Bar

In some instances, raising the height of the unit may require installing the insert with the included Stabilizer Bar. See page 18 of this manual for further details.

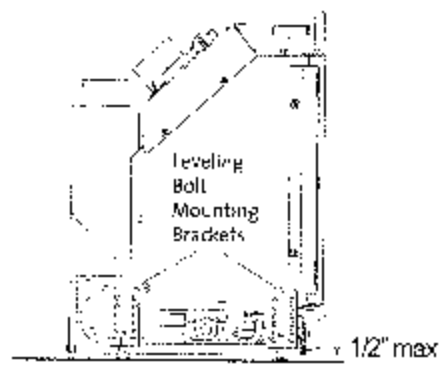

Figure 37. The leveling bolts should not be extended further than $1/2$ ".

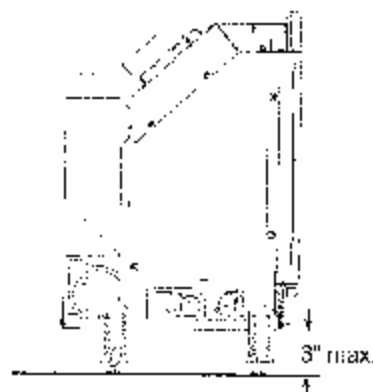

Figure 38. The bolt mounting brackets may be extended up to $2 1/2$ ". With maximum extension of both bolts and brackets, the firebox may be raised a total of 3".

LIGHTING INSTRUCTIONS

FOR YOUR SAFETY, READ BEFORE LIGHTING.

WARNING:

IF YOU DO NOT FOLLOW THESE INSTRUCTIONS EXACTLY, A FIRE OR EXPLOSION MAY RESULT CAUSING PROPERTY DAMAGE, PERSONAL INJURY, OR LOSS OF LIFE.

- A. This appliance has a pilot which must be lit by hand. When lighting the pilot, follow these instructions exactly.
- B. **BEFORE LIGHTING**, smell all around the appliance area for gas. Be sure to smell next to the floor because some gas is heavier than air and will settle to the floor.
- WHAT TO DO IF YOU SMELL GAS:**
- Extinguish any open flame.
 - Open windows.
 - Do not light any appliance.
 - Do not touch any electrical switches.
 - Do not use any phone in your building.
 - Immediately call your gas supplier from a neighbor's phone.
- If your gas supplier cannot be reached, call the fire department.
- C. Use only your hand to push in or turn the gas control knob. Never use tools. If the knob will not push in or turn by hand, do not try to repair it. Call a qualified technician. Force or attempted repair may result in a fire or explosion.
- D. Do not use this appliance if any part has been under water. Immediately call a qualified service technician to inspect the appliance and to replace any part of the control system and any gas control which has been under water.

LIGHTING INSTRUCTIONS

1. STOP! Read the safety information above.
2. Access the lower controls.
3. Turn the stove ON/OFF switch to "OFF" or set the thermostat to lowest setting (if used).
4. Confirm that the gas supply line shut-off valve is open.

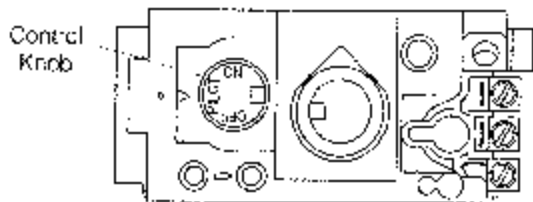

Control Valve

5. Push in gas control knob slightly and turn clockwise  to "OFF".
- NOTE: Knob cannot be turned from "PILOT" to "OFF" unless the knob is pushed in slightly. Do not force.
6. Wait five (5) minutes to clear out any gas. If you then smell gas, STOP! Follow "B" in the safety information above on this page. If you do not smell gas, go to the next step.

7. Push in gas control knob slightly and turn counterclockwise  to "PILOT".
8. Push in control knob all the way and hold in. Immediately light the pilot by triggering the spark ignitor (push the red button repeatedly) until pilot lights. Continue to hold the control knob in for about one minute after the pilot lights. Release knob and it should spring back. The pilot should remain lit. If it goes out, repeat Steps 5 through 8.



Pilot Assembly

- If knob does not return when released, stop and immediately call your service technician or gas supplier.
 - If pilot will not stay lit after several tries, turn the control knob to OFF and call your service technician or gas supplier.
9. Turn gas control knob counterclockwise  to "ON".
 10. Turn the stove ON/OFF switch to "ON", or set thermostat (if used) to desired temperature.

TO TURN OFF GAS TO THE APPLIANCE:

1. Turn ON/OFF switch to "OFF". The pilot will remain lit for normal service.
2. For complete shutdown, turn ON/OFF switch to "OFF".
3. Access the lower controls.
4. Depress gas control knob slightly and turn clockwise  to "OFF". Do not force.

February 2009
129710-C

This appliance must be installed in conformance with local and national building regulations. Before beginning the installation, it is important that the these instructions be carefully read and understood. Jøtul maintains a policy of continual product development. Consequently, products may differ in specification, color or type of accessories from those illustrated or described in various publications.

Jøtul vise sans cesse à améliorer ses produits. C'est pourquoi, il se réserve le droit de modifier ses spécifications, couleurs et équipements sans avis préalable.



Jøtul ASA
P.O. Box 1411
N-1602 Fredrikstad
Norway

Jøtul North America
55 Hutcherson Drive
Gorham, Maine 04038-2534