

Jøtul F 35 Rockwood  
Wood Burning Stove

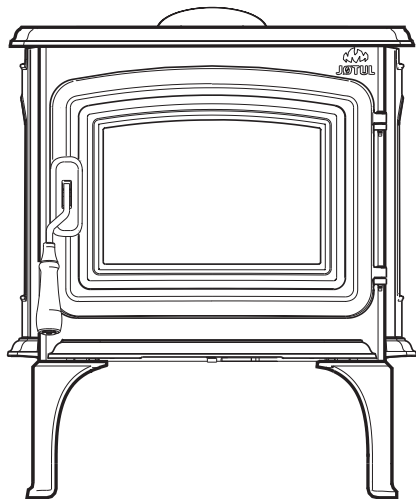

# Jøtul F 35 Rockwood

## Installation and Operating Instructions

- The Jøtul F 35 heater is listed to burn solid wood only.  
Do not burn any other fuels.
- Read this entire manual before you install and use this appliance.
- Save these instructions for future reference and make them available to anyone using or servicing the fireplace insert.
- This wood heater requires periodic inspection and repair for proper operation. See this manual for specific maintenance information. It is against federal regulations to operate this wood heater in a manner inconsistent with the operating instructions in this owner's manual.

**This heater meets the 2020 U.S. Environmental Protection Agency's emission limits for wood heaters manufactured after May 15, 2020.**



*Une version française de ce manuel est disponible au téléchargement sur [www.jotul.ca](http://www.jotul.ca)*

# Table of Contents

<b>Accessories</b> .....	2
<b>Standards / Codes</b> .....	3
<b>Combustion Specifications</b> .....	3
<b>Safety Notices</b> .....	4
<b>1.0 Installation</b>	
1.1 Unpack the Stove.....	5
1.2 Top Exit Flue Adaptor Orientation .....	5
1.3 Short Leg Installation .....	5
1.4 Floor Bracket Installation.....	5
1.5 Rear Exit Flue Collar Orientation.....	6
1.6 Chimney Connector.....	6
<b>2.0 Chimney Requirements</b>	
2.1 Masonry Chimneys .....	7
2.2 Prefabricated Chimneys.....	7
2.3 Chimney Height .....	8
2.4 Wall Pass-Throughs.....	8
<b>3.0 Chimney Connection</b>	
3.1 Masonry Chimneys .....	9
3.2 Hearthmount into a Masonry Fireplace .....	9
3.3 Prefabricated Chimneys.....	10
3.4 Mobile Home Requirements .....	10
<b>4.0 Clearances to Combustibles</b>	
4.1 Floor Protection.....	11
4.2 Clearances to Walls and Ceilings.....	11
4.3 Using Shields to Reduce Clearances.....	11
4.4 Alcove Installation.....	13
4.5 Fireplace Clearances, Mantel and Trim.....	13
4.6 Clearance Diagrams .....	14
4.7 Double Wall Connector Manufacturers .....	15
<b>5.0 Operation</b>	
5.1 Combustion Efficiency.....	16
5.2 CO Emissions .....	16
5.3 Wood Fuel and Performance .....	16
5.4 F 35 Functionality .....	17
5.5 Air Control / Blower Settings.....	17
5.6 Controlling the Fire .....	17
5.7 Break-in Procedure .....	18
5.8 Starting and Maintaining a Fire .....	18
5.9 Adding Fuel .....	19
5.10 Creosote and the Need for Removal .....	19
5.11 Ash Removal.....	19

<b>6.0 Maintenance</b>	
6.1 Door Latch.....	20
6.2 Glass Care.....	20
6.3 General Care .....	20
6.4 Gasket Replacement .....	21
6.5 Glass Replacement .....	21
6.6 Chimney System .....	22
6.7 Firebricks .....	22
6.8 Secondary Manifold Maintenance .....	22
<b>7.0 Optional Accessories</b>	
7.1 Short Leg Installation .....	23
7.2 Outside Air Kit .....	23
7.3 Mobile Home Floor Bracket .....	23
<b>8.0 Appendix</b>	
8.1 Start-Up and Refueling.....	24
<b>9.0 Illustrated Part List</b> .....	26
<b>10.0 Warranty Statement</b> .....	31

---

## Jøtul F 35 Rockwood Accessories

### Stove-Top Thermometer - #5002

We recommend the use of a magnetic stove-top thermometer to monitor the surface temperature of the stove.

The optimum surface temperature range for the most efficient performance is between 400<sup>o</sup> F - 700<sup>o</sup> F (205<sup>o</sup> C - 316<sup>o</sup> C).

### Short Leg Kit - #157636

This kit includes four, 4 1/4” steel legs which allow stove installation into a fireplace opening height as low as 25 1/2”.

**Approved only for code-approved, masonry fireplace hearth mount installation. Not approved for use in mobile homes. See page 23.**

### Mobile Home Floor Bracket Kit - #157321

This kit includes two brackets used to fulfill the mobile home requirement that the stove be secured directly to the floor. See installation instructions on page 23.

### Outside Air Kit - #158265

This kit includes an adaptor collar that allows connection between an exterior wall air inlet through a duct directly to the bottom of the stove fuel bed.

See installation instructions on page 23.

## Standards

The Jøtul F 35 Rockwood non-catalytic heater has been tested and listed to:

U.S.: ANSI/UL 1482

Canada: CAN/ULC-S627 and CAN/ULC-S628

Certified Safety Tests performed by:

ITS, Intertek Testing Services

Middleton, WI

Manufactured by:

Jøtul North America

55 Hutcherson Drive

Gorham, Maine 04038-2644

## Check Building Codes

When installing, operating and maintaining your Jøtul F 35 Rockwood woodstove, follow the guidelines presented in these instructions, and make them available to anyone using or servicing the stove.

Your city, town, county or province may require a building permit to install a solid fuel burning appliance.

**In the U.S.**, the National Fire Protection Association's Code, NFPA 211, *Standards for Chimneys, Fireplaces, Vents and Solid Fuel Burning Appliances*, or similar regulations, may apply to the installation of a solid fuel burning appliance in your area.

**In Canada**, the guideline is established by the CSA Standard, CAN/CSA-B365-M93, *Installation Code for Solid-Fuel-Burning Appliances and Equipment*.

Always consult your local building inspector or authority having jurisdiction to determine what regulations apply in your area.

The Jøtul F 35 Rockwood is approved for use in mobile homes. Install in accordance with 24 CFR, Part 3280 (HUD). Follow the instructions in this manual.



### WARNING !

**THIS WOOD HEATER HAS A MANUFACTURER-SET MINIMUM LOW BURN RATE THAT MUST NOT BE ALTERED. IT IS AGAINST FEDERAL REGULATIONS TO ALTER THIS SETTING OR OTHERWISE OPERATE THIS WOOD HEATER IN A MANNER INCONSISTENT WITH OPERATING INSTRUCTIONS IN THIS MANUAL.**

## Combustion Specifications

<b>Heat Output Range:</b> <sup>1</sup>	13,533 to 59,443 BTU/hr.
<b>Heating Capacity:</b> <sup>2</sup>	Up to 1,200 sq. ft.
<b>Maximum Burn Time:</b>	Up to 6 3/4 hours
<b>EPA Efficiency:</b> <sup>3</sup>	<b>HHV:</b> 68.5% <b>LHV:</b> 73.67%
<b>CO Emissions:</b> <sup>4</sup>	1.35 g/min
<b>Particulate Emissions:</b> <sup>5</sup>	1.2 g/hr - Cord Wood
<b>Fuel:</b>	16" Logs (40 cm) Front to Back

See the Operation section of this manual for important information regarding the safe, proper, and most efficient operation of your stove.

- 1. Heat Output Range** results are determined during specific emissions tests established by the EPA.
- 2. Heating Capacity** will vary depending on design of home, climate, wood type and operation.
- 3. EPA Validated Efficiency:**  
High Heat Value (HHV) and Low Heat Value (LHV) efficiencies are determined per the CSA B415.1-10 test method. The difference between the HHV and LHV is in how the energy in the exhaust gas water vapor is accounted. LHV efficiency assumes all the water vapor in combustion gas was condensed and the heat from such was recovered and transferred to the dwelling. HHV calculations do not assume all water vapor is condensed, therefore the HHV value is less than the LHV value.
- 4. Carbon Monoxide Emissions** rate results from Test Method CSA B415.1-10.
- 5. Particulate Emissions** rate is obtained using EPA Test Methods:  
ALT-125 (Cordwood Fuel)  
ASTM E2515  
ASTM E3053

NATIONAL  
FIREPLACE  
INSTITUTE



CERTIFIED  
www.nficertified.org

We suggest that our woodburning hearth products be installed and serviced by professionals who are certified in the U.S. by the National Fireplace Institute® (NFI) as NFI Woodburning Specialists or who are certified in Canada by Wood Energy Technical Training (WETT).



## Safety Notices

- **BURN SOLID, NATURAL WOOD FUEL ONLY. DO NOT BURN ANY OTHER FUEL.**
- **DO NOT USE CHEMICALS OR FLUIDS TO START A FIRE. DO NOT BURN GARBAGE OR FLAMMABLE FUELS.**
- **DO NOT USE A GRATE OR ELEVATE THE FIRE. BUILD THE FIRE DIRECTLY ON THE HEARTH.**
- **IF THIS ROOM HEATER IS NOT PROPERLY INSTALLED, A HOUSE FIRE MAY RESULT. TO REDUCE THE RISK OF FIRE, FOLLOW THE INSTRUCTIONS IN THIS MANUAL. FAILURE TO FOLLOW THESE INSTRUCTIONS MAY RESULT IN PROPERTY DAMAGE, BODILY INJURY, OR LOSS OF LIFE.**
- **CONTACT LOCAL BUILDING OR FIRE OFFICIALS ABOUT RESTRICTIONS AND INSTALLATION INSPECTION REQUIREMENTS IN YOUR AREA.**
- **ANY EXISTING CHIMNEY SYSTEM MUST BE INSPECTED BEFORE INSTALLATION OF THIS APPLIANCE.**
- **DO NOT CONNECT THIS STOVE TO ANY AIR DISTRIBUTION DUCT OR SYSTEM.**
- **EXTREMELY HOT WHILE IN OPERATION! KEEP CHILDREN, CLOTHING, AND FURNITURE AWAY. CONTACT WILL CAUSE SKIN BURNS. USE A CHILD GUARD SCREEN TO PREVENT ACCIDENTAL CONTACT BY SMALL CHILDREN.**
- **INSTALL SMOKE DETECTORS IN THE LIVING AREA AND BEDROOMS OF YOUR HOME. TEST THEM REGULARLY AND INSTALL FRESH BATTERIES TWICE ANNUALLY.**  
**WHEN INSTALLED IN THE SAME ROOM AS THE STOVE, A SMOKE OR CARBON MONOXIDE DETECTOR SHOULD BE LOCATED AS FAR FROM THE STOVE AS POSSIBLE TO PREVENT THE ALARM SOUNDING WHEN ADDING FUEL.**
- **Avoid creating a low pressure condition in the room where the stove is operating. Be aware that operation of an exhaust fan or clothes dryer can create a low pressure area and consequently promote flow reversal through the stove and chimney system. In some cases, the optional Outside Air Kit #157637 can be used to alleviate this condition. The chimney and building, however, always work together as a system - provision of outside air, directly or indirectly to an atmospherically vented appliance will not guarantee proper chimney performance. Consult your local Jøtul authorized dealer regarding specific installation/performance issues.**
- **Jøtul strongly recommends that this stove be installed by a professional solid fuel technician, or that you consult one if you do the work yourself. Also, consult your insurance company regarding any other specific requirements.**

## 1.0 Installation

**If this solid fuel room heater is not properly installed, a house fire may result. For your safety, follow the installation directions. Contact the local building or fire officials about restrictions and installation inspection requirements in your area.**

Your local officials have final authority in determining if a proposed installation is acceptable. Any requirement by the local authority having jurisdiction that is not specifically addressed in this manual, defaults to NFPA 211, and local codes in the U.S. or in Canada, CAN/CSA-B365-M and local codes.

### Recommended Installation Tools

- Measuring Tape
- Phillips screwdriver
- 10 mm open-end or socket wrench
- Work Gloves
- Safety Glasses
- 4 mm hex key
- 13 mm open-end or socket wrench

### PLEASE NOTE:

**IT IS NORMAL FOR SMOKE AND ODOR TO OCCUR DURING THE INITIAL STAGES OF OPERATION, DEPENDING UPON TEMPERATURES GENERATED OVER TIME. THIS "CURING" CONDITION CAN BE ALLEVIATED BY PROMOTING FRESH AIR CIRCULATION WITHIN THE IMMEDIATE VICINITY OF THE APPLIANCE.**

## 1.1 Unpack the Stove

Inspect the stove for damage. Contact your dealer immediately if any damage is found. Do not install the stove if any damage is evident.

### Contents:

- Miscellaneous Hardware
- Single-wall 45° adaptor
- Double-wall Starter Collar P/N 227144

**NOTE: The integral Rear Shroud acts as a heat shield. There is no accessory stove heat shield.**

**DO NOT REMOVE THE REAR HEAT SHIELD**

## 1.2 Short Leg Kit 157636 Installation

This set of four steel legs reduces stove height by 3 1/4 inches allowing installation into fireplaces having a low lintel.

See fig. 22, page 21. **Approved for use only in a code-approved, masonry fireplace.**

## 1.3 Floor Bracket Kit 157321

Install this kit to conform to Mobile Home code woodstove installation requirements. See fig. 24, page 21.

## 1.4 Flue Outlet Orientation

The cast iron flue collar is oriented to exit at 45°. A 45° single-wall sheet metal adaptor is provided. This adaptor can be used to change the orientation to rear exit or top exit on single-wall installations only. If using a double-wall pipe use the included double-wall starter collar and a 45° double-wall elbow (not included). See pages 15 for common adapter manufacturers and double-wall pipe clearances.

**NOTE:** The single-wall 45° adaptor that is provided with the stove must be used to maintain the listed clearances in the manual.

**CONNECTING DOUBLE WALL PIPE TO A SINGLE WALL ADAPTOR WILL VIOLATE SAFETY COMPLIANCE.**

**Single Wall Pipe Installation:** Secure the provided 45° adaptor to the cast flue collar holes with the two screws provided.

**Double Wall Pipe Installation:** Secure the Double Wall Starter Collar to the cast flue collar holes with the two screws provided. Then, attach the 45° double wall elbow (not provided) to the Double Wall Starter Collar with three sheet metal screws. (not provided) Please refer to page 15, Table A in the manual for the correct clearance that corresponds to the pipe manufacturer used and the stove position of your installation

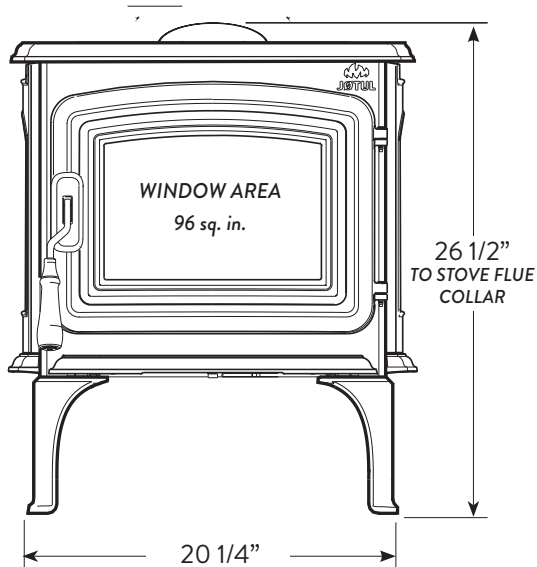
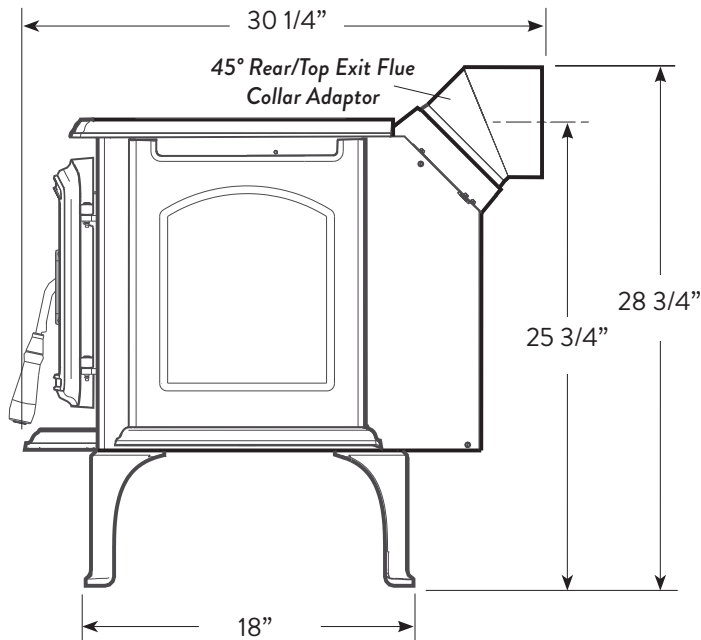
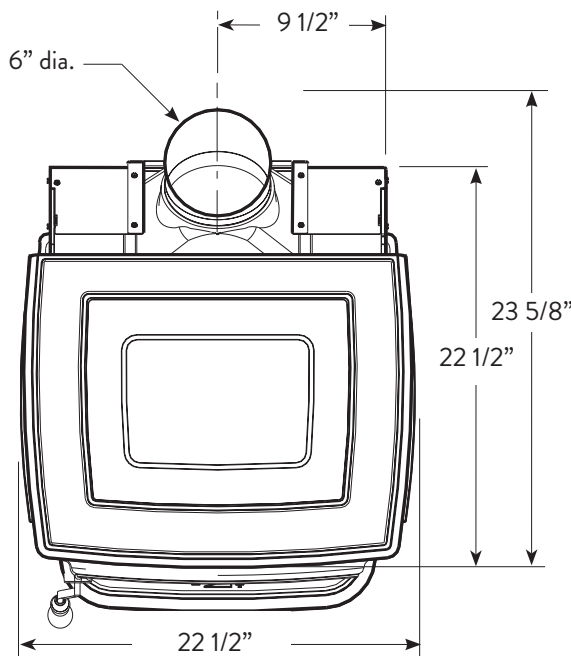

Figure 1. F 35 dimensional views.

**Use Short Leg Kit #157636 to reduce stove height by 3 1/4". Hearthmount installation only.**

## 1.6 Chimney Connector

Use 6" single wall or listed 6" double-wall stovepipe to connect the stove to the chimney. Single wall stovepipe must be black steel or stainless steel and have a minimum thickness of 24 gauge. Do not use aluminum or galvanized steel pipe for chimney connection - these materials are not suitable for use with solid fuel. Attach the flue collar to the chimney connection using 2 self-drilling screws found in the miscellaneous kit.

Follow these guidelines:

- Do not use chimney connector as a chimney. It is intended only as a connection device to a code approved chimney.
- Each connector section must be oriented with the male (crimped) end pointing toward the stove. See fig. 3.
- Secure all connector joints with three sheet metal screws.
- For the best performance, the chimney connector should be as short and direct as possible, including no more than two 90° elbows.
- **The maximum vertical run of single wall stovepipe should not exceed 10 ft.**
- **The maximum horizontal run should not exceed 3 ft. with a 1/4" rise per foot.** Under no circumstance should horizontal pipe be installed slanting down toward the chimney.
- No part of the chimney connector may pass through an attic or roof space, closet or other concealed space, or through a floor or ceiling. All sections of the chimney connectors must be accessible for cleaning.
- Where passage through a wall or partition of combustible construction is desired, the installation must conform with NFPA 211 or CAN/CSA-B365, and is also addressed in this manual.
- **Do not connect this stove to a chimney flue serving another appliance.**

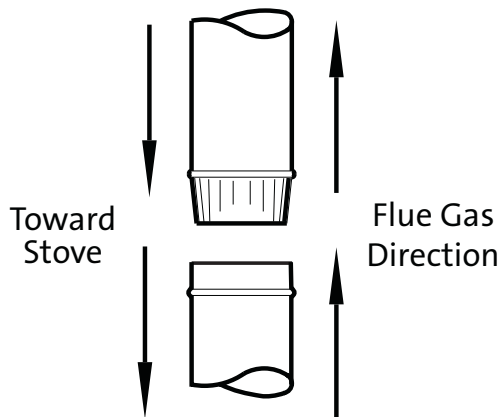

Figure 3. Chimney connector orientation.

## 2.0 Chimney Requirements

There are two types of approved chimneys:

1. A code-approved masonry chimney with a ceramic tile or listed steel flue liner.
2. A prefabricated chimney complying with the requirements for Type HT (2100°F) chimneys per UL 103 or ULC S629.

An NFPA 211 Level 1 chimney inspection should be performed prior to installation. Depending on specific circumstances and the outcome of the Level 1 inspection it may be determined that a Level 2 or 3 inspection is also necessary.

The chimney size should not be less than the cross-sectional area of the flue collar, and not more than three times greater than the cross-sectional area of the flue collar. If the chimney flue is outdoors, its cross-sectional area may not exceed two times greater than the stove flue collar. See also Sect. 3.2.

When selecting a chimney type and the location for the chimney in the house, keep this in mind: **It is the chimney that makes the stove work - not the stove that makes the chimney work.** This is because a chimney actually creates a suction, called "draft" which pulls air through the stove.

Several factors affect draft: chimney height, cross-sectional area (size), and temperature of the chimney, as well as the proximity of surrounding trees or buildings.

A short exterior masonry chimney will give the poorest performance because it will be difficult to warm the flue and sustain the temperatures necessary to maintain draft strength. In extremely cold climates, it may be necessary to reline the chimney or extend the height to help establish draft.

A tall, interior masonry chimney is easier to keep warm and will perform well under a variety of weather and environmental conditions.

The following guidelines give the necessary chimney requirements based on the national code (ANSI-NFPA 211 for the US. And CSA CAN-B365 for Canada). However, many local codes differ from the national code to take into account climate, altitude, or other factors. Your local building inspector is the final approving authority. Consult them prior to installation.

**Do not connect the stove to any air distribution duct or system.**

### 2.1 Masonry Chimneys

Follow these guidelines when installing the Jøtul F 35 into a masonry chimney:

- The masonry chimney must have a fireclay liner or equivalent, with a minimum thickness of 5/8" (14 mm) and must be installed with refractory mortar. There must be at least 1/2" air space between the flue liner and chimney wall.
- The fireclay flue liner must have a nominal size of 8" X 8", and should not be larger than 8" X 12". A round fireclay liner must have a minimum inside diameter of 6" and maximum inside diameter of 8".

A larger chimney should be relined with an appropriate code approved liner.

- Brick or modular block must be a minimum of 4" nominal thickness. Stone construction must be at least 12" thick.
- A newly-built chimney must conform to local codes, or, in their absence, must comply with national regulations.
- An existing chimney must be subjected to a Level I inspection by a professional, licensed chimney sweep, fire official, or code officer to ensure that the chimney is in proper working order. Any repairs must be completed before installing the stove.
- A Level II inspection is indicated when verification of the suitability of the chimney for new or changed conditions of service is needed, or when a Level I inspection is not sufficient to determine the serviceability of the chimney is needed.
- No other appliance may be vented into the same flue.
- An airtight clean-out door should be located at the base of the chimney.

## 2.2 Prefabricated Chimneys

A prefabricated metal chimney must be tested and listed for use with solid fuel burning appliances. High Temperature (HT) Chimney Standard UL 103 for the U.S. and High Temperature Standard ULC S-629 for Canada.

The manufacturer's installation instructions must be followed precisely. Always maintain the proper clearance to combustibles as established by the pipe manufacturer. This clearance is usually a minimum of 2", although it may vary by manufacturer or for certain chimney components.

## 2.3 Chimney Height

The chimney must be at least 3 feet higher than the highest point where it passes through the roof and at least 2 feet higher than the highest part of the roof or structure that is within 10 feet of the chimney, measured horizontally. See fig. 4.

Chimneys shorter than 14 feet may not provide adequate draft. Inadequate draft can result in smoke spillage when loading the stove, or when the door is open. Poor draft can also cause back puffing (ignition of gas build-up inside the firebox) and sluggish performance. The minimum height does not, in itself, guarantee proper chimney performance. Optimum draft force should be in the .05 - .10 in. w.c. range measured by a Magnahelic gauge. Draft at .07 w.c. is ideal.

Excessive chimney height can promote over-strong draft resulting in high stove temperatures and short burn times. Your Jøtul dealer is an expert resource to consult regarding draft issues or other performance-related questions.

## 2.4 Wall Pass-Throughs

Note: In addition to the methods described here, any listed, prefabricated wall pass-through components available from chimney manufacturers may be used.

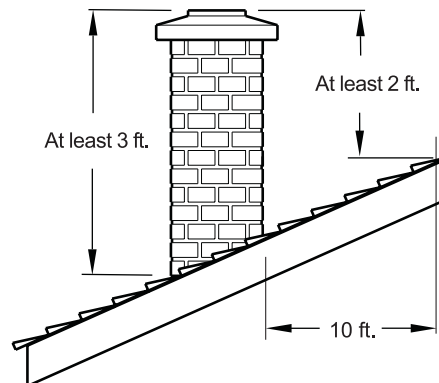

Figure 4. Chimney Height Requirement.

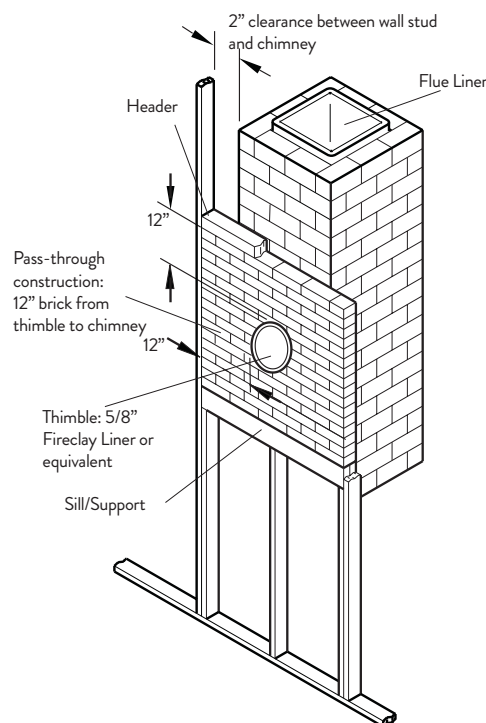

Figure 5. Masonry Wall Pass-through.

### In the U.S.

The National Fire Protection Association's publication, NFPA 211, *Standard for Chimneys, Fireplaces, Vents and Solid Fuel Burning Appliances* permits four methods for passing through a combustible wall. Before proceeding with any method be sure to consult with your local building officials to discuss any local code requirements.

#### Common Method:

See fig. 5. Remove all combustible materials from the pass-through area (around the chimney connector), a minimum 12". A 6" diameter connector will require a 31" x 31" square opening.

The opening must be filled with at least 12" of brick around a fireclay liner. The liner must be ASTM C35 or equivalent, having a minimum wall thickness of 5/8".

The Pass-through must be at least 18" from combustible ceiling materials.

It will be necessary to cut wall studs, install headers, and construct a sill frame to maintain the proper dimensions and to support the weight of the brick.

The bricks must be solid brick with a minimum of 3 inches thick (nominal 4”).

Refractory mortar must be used at the junction of the chimney and the pass-through liner. The pass-through liner must not penetrate the chimney liner beyond the inner surface of the chimney liner. Use extreme care when constructing the hole in the chimney liner as the tiles can shatter easily.

### In Canada

The installation must conform to CAN/CSA-B365, Installation Code for Solid Fuel Burning Appliances and Equipment. Before proceeding be sure to consult your local building inspector.

#### Common Method:

This method requires the removal of all combustible materials from at least 18” around the chimney connector’s proposed location. A 6” round liner requires a minimum opening 43” x 43” square.

Locate the pass-through at least 18” from combustible ceiling materials.

The space that is cleared of combustible materials must remain empty. Sheet metal panels can be used to cover the area. However, when using a panel on both sides of the wall, each cover must be installed on noncombustible spacers at least 1” from the wall. If one panel of sheet metal is to be used it may be installed flush to the wall.

See section 5.3.1 and 5.3.2 of CAN/CSA - B365-M91. Consult your local building inspector, authorized Jøtul Dealer, NFPA 211 in the U.S. or CAN/CSA-B635 in Canada for other approved wall pass-through methods.

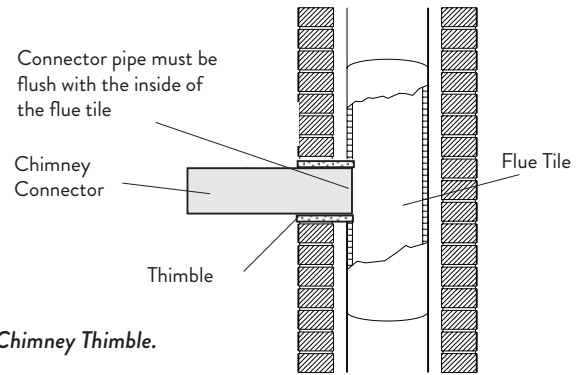

Figure 6. Masonry Chimney Thimble.

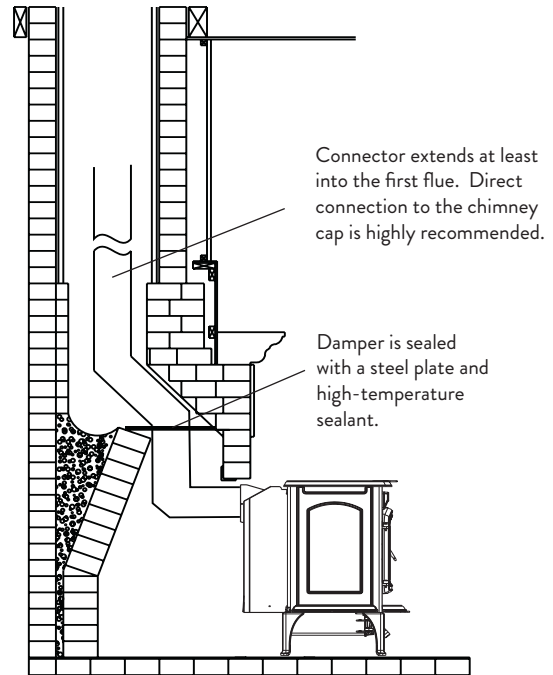

Figure 7. Hearthmount Installation.

NOT TO BE INSTALLED IN ANY FACTORY BUILT FIREPLACE

## 3.0 Connecting to the Chimney

### 3.1 Masonry Chimney

A ceramic or steel thimble is commonly used to penetrate the chimney wall into the flue. The chimney connector/stove pipe must slide completely inside thimble to the inner surface or the flue liner. It may be necessary to include a thimble sleeve having a slightly larger diameter than the connector pipe. See **fig. 6**.

The connector pipe and/or thimble sleeve must not protrude into the flue liner or otherwise restrict draft.

Use refractory cement to seal the seams between the chimney connector, sleeve, and thimble.

**Do not connect this stove to a chimney flue servicing another appliance of any kind.**

### 3.2 Hearthmount into a Masonry Fireplace

The Jøtul F 35 on standard legs may be installed into a masonry fireplace with a minimum opening height of 27".

Use Short Leg Kit 157636 to install into a fireplace with a minimum opening height of 23 1/8". **Short legs are approved only for use on a code-approved, masonry fireplace and hearth.**

Building code requires that the fireplace damper plate be removed or securely fixed in the open position.

A connector pipe must then extend from the stove's flue exit through the damper area of the fireplace and into the chimney tile liner. See **fig. 7**. In any case, **we recommend that a full liner be installed through any masonry chimney to ensure good performance.**

The cross-sectional area of the flue of a chimney with no walls exposed to the outside below the roof line may be no more than three times the cross-sectional area of the stove flue collar.

The cross-sectional area of the flue of a chimney with one or more walls exposed to the outside below the roof line may be no more than two times the cross-sectional area of the stove flue collar.

If the chimney liner is too large to accommodate the stove, an approved relining system must be installed to resize the flue.

A new sheet metal damper block-off plate must be installed around the connector pipe at the damper frame and sealed with the proper sealant (usually High-Temp Silicone).

**DO NOT INSTALL IN ANY FIREPLACE.**

The F 35 may be vented through a masonry fireplace as described above but the stove must be installed **IN FRONT** of the fireplace opening.

### 3.3 Prefabricated Chimneys

When connecting the Jøtul F 35 to a prefabricated metal chimney always follow the pipe manufacturer's instructions and be sure to use the all components that are required. This usually includes a chimney adaptor that is secured to the bottom section of the metal chimney and allows the chimney pipe to be secured to it with two sheet metal screws. See **fig. 8**.

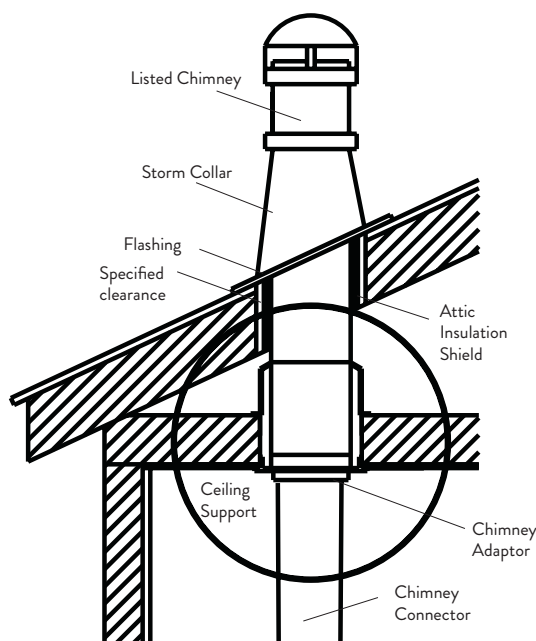

Figure 8. Prefabricated Listed Type HT Chimney.

### 3.4 Mobile Home Installation

The Jøtul F 35 is approved for installation in manufactured mobile homes provided the following requirements are met:

1. All chimney components, including chimney sections, supports, spark arrestor, etc., shall comply with the Standard for Factory-built Chimneys for Residential Type and Building Heating Appliances, UL 103 and/or CAN/ULC-S629 Standard for 650°C Factory-built Chimneys.
2. The chimney shall be attached directly to the stove and extend at least 3 ft. above the roof. Termination must be at least 2 ft. above the highest elevation of any part of the mobile home within 10 ft. Close clearance pipe must be used.
3. All heat shields must remain on the stove.
4. In order to allow for transportation of the mobile home, the chimney termination shall be readily removed at or below an elevation of 13.5 ft. above ground level and reinstalled without use of special tools or instructions.
5. A spark arrestor must be installed at the termination. The net free area of the arrestor above the chimney outlet must not be less than four times the net area of the chimney outlet, and the vertical height of the arrestor must not be less than one-half the diameter of the chimney flue. Openings shall not permit the passage of a sphere having a diameter larger than 1/2", and shall permit the passage of a sphere having a diameter of 3/8".
6. Direct connection of the stove to an outside air source is required. Use Outside Air Kit #158265 . Do not substitute any other connection method or device. See Appendix, Section 7.0. Duct termination must not be installed at a level that is higher than the air inlet located at the bottom of the stove.
7. The stove must be secured to the mobile home floor. Use Floor Bracket Kit 157321.
8. When the chimney exits the mobile home at a location other than through the roof, and exits at a point 7 ft. or less above the ground level, a guard or other method of enclosing the chimney, must be provided at the point of exit for a height up to 7 ft. Openings of this chimney guard shall not permit penetration of a 3/4 in. diameter rod, or contact with the chimney by a 1/2 inch diameter rod inserted through the opening a distance of 4 inches.
9. Provision must be made for electrical grounding of the chimney, chimney connector, and stove in accordance with local building codes.

**WARNING: Do not install this appliance in a sleeping room.**

**CAUTION: The structural integrity of the mobile home floor, walls, and ceiling/roof must be maintained.**

## 4.0 Clearance to Combustibles

### 4.1 Floor Protection

The **Bottom Heat Shield must remain on the stove** unless the stove is installed on concrete poured on earth.

The Jøtul F 35 also requires one of the following forms of hearth protection if not installed directly on concrete poured on earth:

Any continuous non-combustible material or properly sized UL/ULC Type I or Type II hearth pad

All floor protection materials must be non-combustible (i.e., metals, brick, stone, mineral fiber boards, etc.). Any organic materials (i.e., plastics, wood, paper products, etc.) are combustible and must not be used.

**IN THE U.S.: Floor protection must extend continuously forward from the door opening at least 16 in. and 8 in. from the sides of the door opening.** Protection must also extend 2 in. from the rear and 2" to the sides under any horizontal or vertical chimney connector. This will result in a minimum floor protector measuring 30" wide x 40.5" deep for rear exit and 30" wide x 43.25" deep for top exit. See figs 9 and 9a.

**IN CANADA: Floor protection must extend continuously 18" from the front of the stove and 8 in. from the sides and rear.** It must also extend 2 in. under any horizontal chimney connector. This results in a floor protector dimension of 39" wide x 48.5" deep for rear exit and 39" wide x 47.75" deep for top exit. See figs.10 and 10a.

### 4.2 Clearances to Walls and Ceilings

The clearances listed and diagramed in this manual have been tested to UL and ULC standards and are the minimum clearances to combustible materials specifically established for the Jøtul F 35.

A combustible surface is anything that can burn (i.e. sheet rock, wall paper, wood, fabrics etc.). These surfaces are not limited to those that are visible and also include materials that are behind non-combustible materials. If you are not sure of the combustible nature of a material, consult your local fire officials.

Remember: "Fire Resistant" materials are considered combustible; they are difficult to ignite, but will burn. Also "Fire-rated" sheet rock is also considered combustible.

Contact your local building officials about restrictions and installation requirements in your area. See pages 12-15 for clearance requirements and diagrams.

### 4.3 Using Shields to Reduce Clearances

**Double Wall Connector:** Listed double wall pipe is an acceptable alternative to connector pipe heat shields.

**Wall-Mounted Protection:** When reducing clearances through the use of wall-mounted protection:

**In the U.S. refer to NFPA 211, Standard for Chimneys, Fireplaces, Vents and Solid Fuel Burning Appliances,** for acceptable materials, proper sizing and construction guidelines.

**In Canada, refer to CAN/CSA-B365, Installation Code for Solid-Fuel Burning Appliances and Equipment,** also for acceptable materials, proper sizing and construction guidelines.

**Notice:** Many manufacturers have developed woodstove accessories that permit clearance reduction. Use only those accessories that have been tested by an independent laboratory and carry the laboratory's testing mark. Be sure to follow all of the manufacturer's instructions.

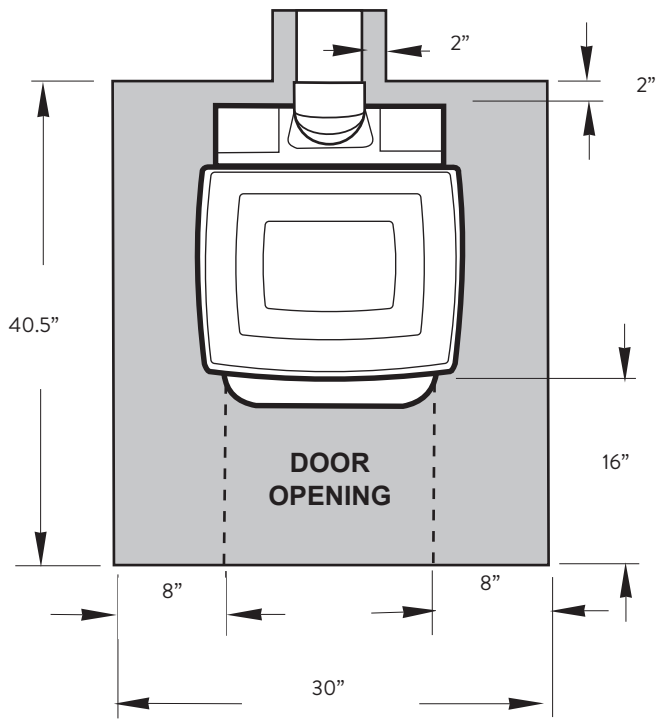

Figure 9. Floor Protection minimum dimensions, U.S. Rear Exit.

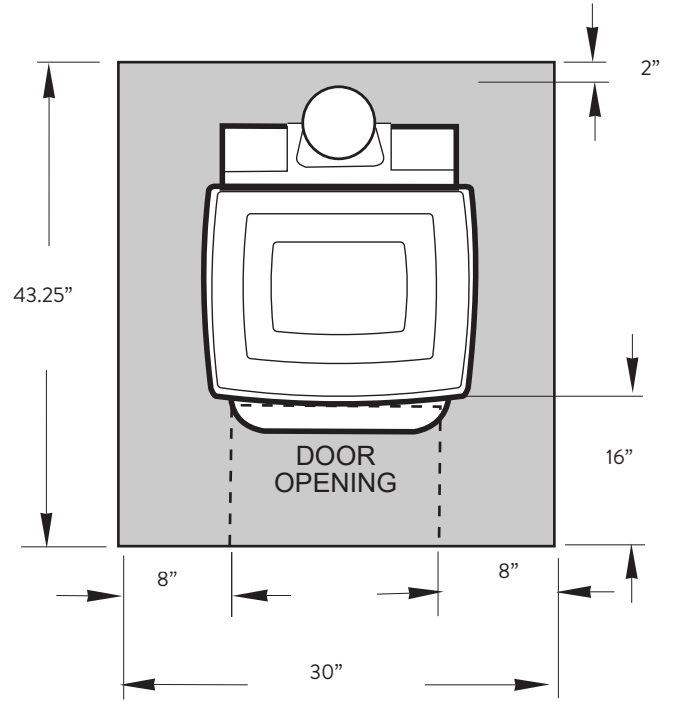

Figure 9a. Floor Protection minimum dimensions, U.S. Top Exit.

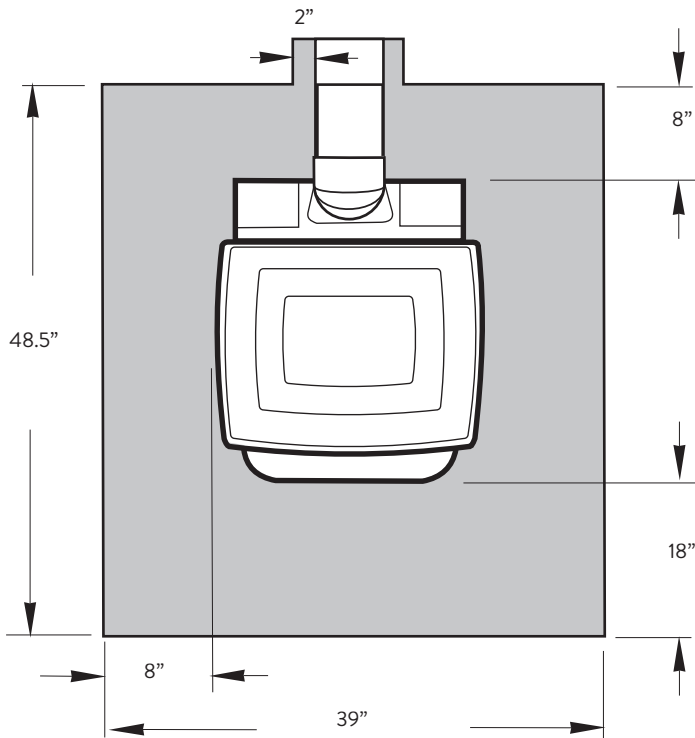

Figure 10. Floor Protection minimum dimensions, CAN. Rear Exit.

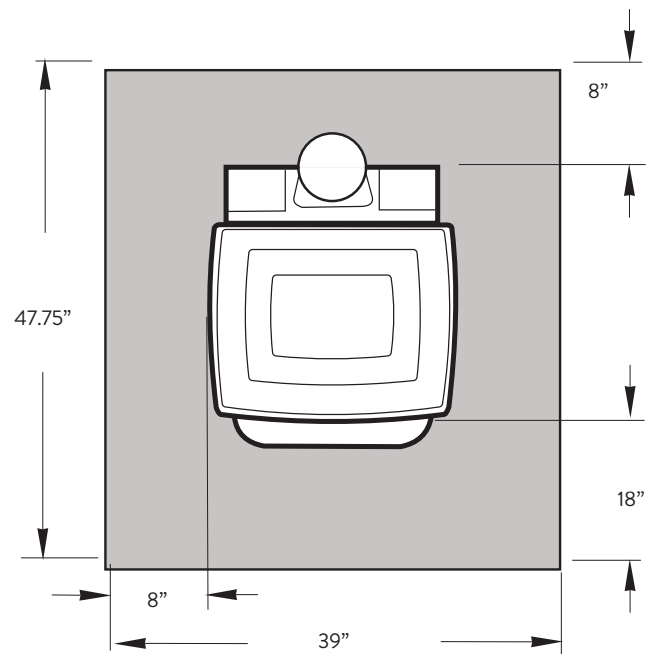

Figure 10a. Floor Protection minimum dimensions, CAN. Top Exit.

### 4.4 Alcove Installation

The Jøtul F 35 can be installed in an alcove as diagrammed in **figs. 11.-12.**

1. **Only double-wall chimney connector may be used.**
2. Wall and ceiling protection, if used, must extend over the entire area.
3. Alcove floor protection must consist of a continuous non-combustible material.
4. **Minimum Alcove Ceiling Height from Floor:**  
 Unprotected Surface - 72"  
 Protected Surface - 65"

*The Short Leg option is not approved for use in Alcove installations.*

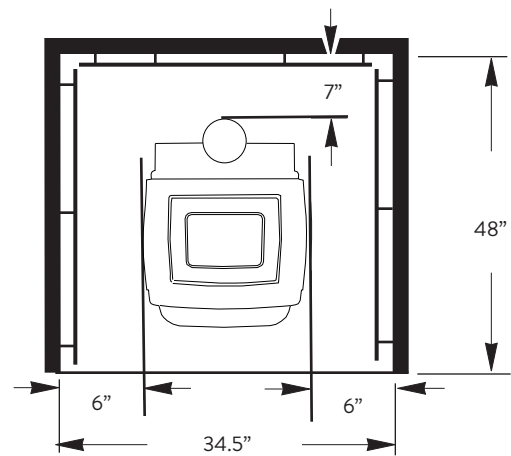

Figure 12. Alcove with Wall Protection.

### 4.5 Clearances to Fireplace Mantels and Surrounding Trim

See fig. 13 and the Clearance Chart on page 14 for approved clearances to combustible materials that may be part of fireplace construction.

Mantel and Trim clearances may be reduced by 50%, up to a minimum of 18", with use of shielding constructed in accordance with NFPA 211 specifications.

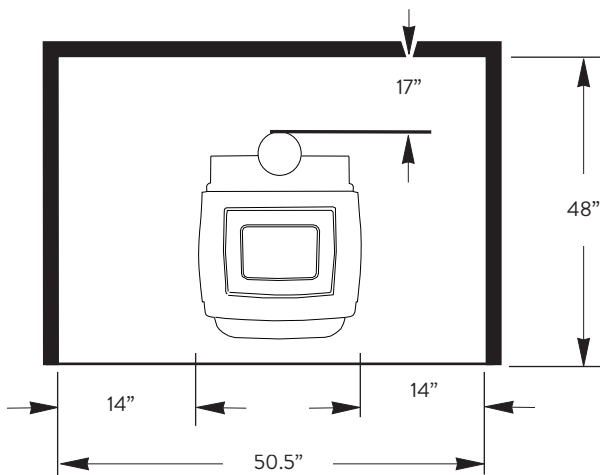
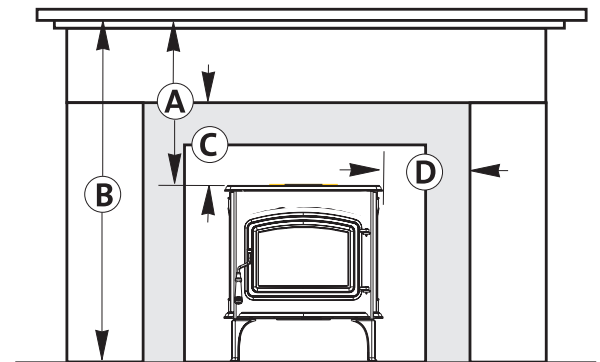

Figure 11. Alcove Clearances.



- A: Unit to Mantel (12 in. deep) - 20 in.
- B: Floor to Mantel - 46 in.
- C: Stove to 1 in. Top Trim - 16 in.
- D: Stove to 1 in. Side Trim - 8 in.
- Non-combustible Material

Figure 13. Mantel and Trim Clearances

*Note: Short Legs reduce stove height by 3 1/4"*

### 4.6 Jøtul F 35 Clearance Specifications

	UNPROTECTED WALLS					PROTECTED WALLS PER NFPA211 OR CAN/CSA-B365-M93				
	SIDE	REAR	CORNER	CORNER TO FRONT FLOOR PROTECTION**	FRONT FLOOR PROTECTION WIDTH**	SIDE	REAR	CORNER	CORNER TO FRONT FLOOR PROTECTION**	FRONT FLOOR PROTECTION WIDTH**
Single Wall Connector	A 13"	B 14"	C 10"	D US: 62 1/2" CAN: 64 1/2"	E US: 29 5/8" CAN: 37"	F 4"	G 6"	H 4"	I US: 54" CAN: 56"	J US: 29 5/8" CAN: 37"
Double Wall Connector	A 13"	K *	C 9"*	L US: 61" CAN 63"	E US: 29 5/8" CAN: 37"	F 4"	N *	M 4"*	I US: 54" CAN: 56"	J US: 29 5/8" CAN: 37"

\* See Table A, Pg. 15 for installation specifics.

\*\* US and CAN measurements are not the same and are not interchangeable.

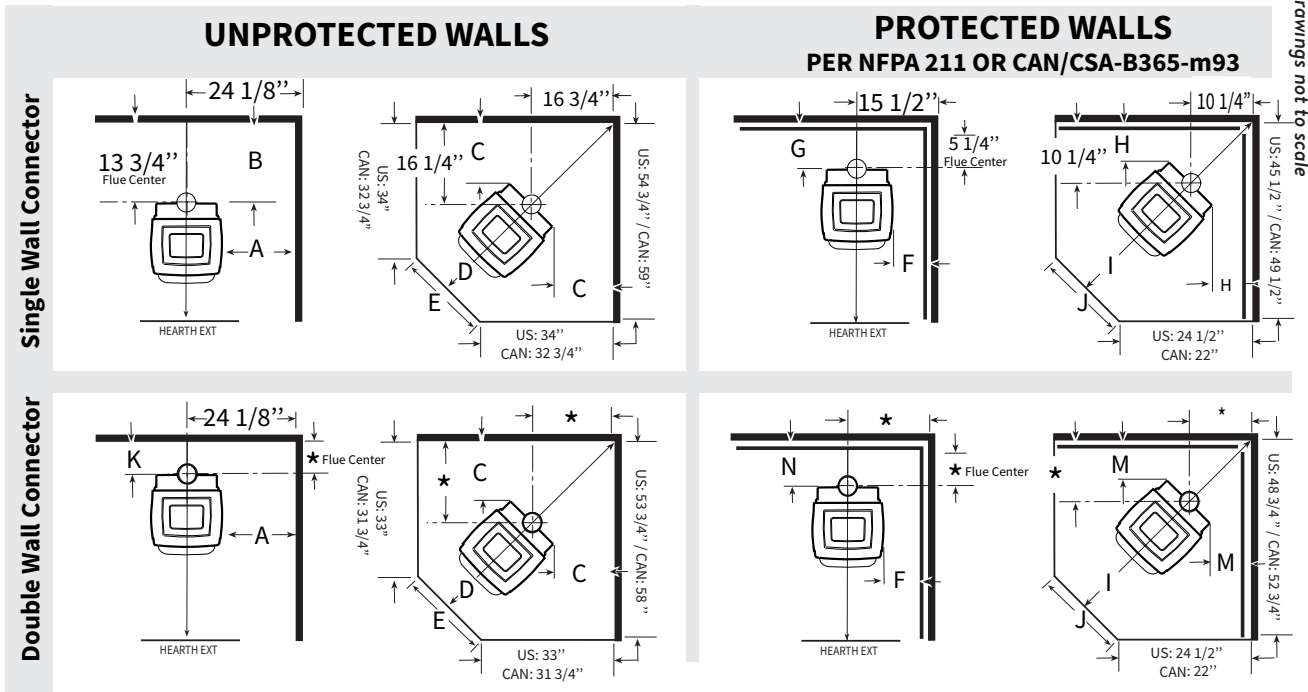

Figure 14.

**Note: Double walled pipe requires the use of the double wall 45° adaptor. DO NOT USE THE SUPPLIED SINGLE WALL 45° ADAPTOR. CONNECTING DOUBLE WALL PIPE TO A SINGLE WALL ADAPTOR WILL VIOLATE SAFETY COMPLIANCE.**

**Table A**

<b>F 35 with Double Wall Chimney Connector Installation Specifications</b>					
<b>K</b>	<b>Standard Install without wall protection</b>			<b>Front Edge of Hearth Extension From Rear Wall</b>	
	Brand	Backwall with DW Pipe at 6"	Centerline from backwall	U.S.	Canada
	ICC	10 1/8" (257mm)	9 1/8" (232mm)	48 3/8" (1229mm)	52 3/4" (1340mm)
	Ventis	11 7/8" (302mm)	9 1/2" (241mm)	50 1/8" (1273mm)	55 1/8" (1400mm)
	Security	10 7/8" (276mm)	9 5/8" (232mm)	49 1/8" (1248mm)	56 1/8" (1426mm)
	Selkirk	10 3/8" (264mm)	9 3/8" (238mm)	48 5/8" (1235mm)	56 3/8" (1432mm)
	DuraVent	11 3/8" (289mm)	9 3/8" (238mm)	49 5/8" (1260mm)	56 5/8" (1445mm)
<b>N</b>	<b>Standard Install with wall protection</b>			<b>Front Edge of Hearth Extension From Rear Wall</b>	
	Brand	Backwall with DW Pipe at 2 3/8"	Centerline from backwall	U.S.	Canada
	ICC	6 1/2" (165mm)	5 1/2" (140mm)	44 3/4" (1137mm)	49 1/8" (1248mm)
	Ventis	8 1/4" (210mm)	5 7/8" (149mm)	46 1/2" (1181mm)	51 7/16" (1307mm)
	Security	7 1/4" (184mm)	5 1/2" (140mm)	42 1/2" (1080mm)	52 1/2" (1334mm)
	Selkirk	6 3/4" (171mm)	5 3/4" (146mm)	45" (1143mm)	52 3/4" (1340mm)
	DuraVent	7 3/4" (197mm)	5 3/4" (146mm)	46" (1168mm)	53 1/4" (1353mm)
<b>C</b>	<b>Corner Installation at 9" without wall protection</b>				
	Brand	Chimney Centerline dimension			
		From corner and wall			
	ICC	15 1/4" (387mm)			
	Ventis	14 1/4" (362mm)			
	Security	14 3/8" (365mm)			
	DuraVent	11 3/4" (298mm)			
<b>M</b>	<b>Corner Installation at 4" with wall protection</b>				
	Brand	Chimney Centerline dimension			
		From corner and wall			
	ICC	10 1/4" (260mm)			
	Ventis	9 1/4" (235mm)			
	Security	9 5/8" (244mm)			
	DuraVent	9 1/2" (241mm)			

**ICC**  
45° Elbow Part Number VE-6UB45

**Selkirk**  
45° Elbow Part Number 45073 DSP6E4-1

**Ventis/Copperfield**  
45° Elbow Part Number 3602438

**Dura Vent**  
45° Elbow Part Number 6DVL-E45

**Security**  
45° Elbow Part Number 6DE45

## 5.0 Operation

Please read the following section before building the first fire in your new Jøtul F 35 Rockwood.

### 5.1 Combustion Efficiency

The Jøtul F 35 Rockwood has an EPA tested High Heating Value (HHV) efficiency rate of 68.47%. There are aspects of efficiency, however, that you should be aware of in order to get the most from your stove.

Operation habits and fuel moisture can have a significant effect on efficiency. Poorly seasoned wood having a higher than optimum moisture content, can reduce the amount of energy transferred to the living area as a result of the energy expended to evaporate the excess fuel moisture in order for the wood to burn. Operational aspects, such as not building a robust kindling fire to readily ignite the larger fuel pieces, can result in an inefficient smoldering fire. Additionally, most modern wood heaters' optimum performance and efficiency are at the medium to medium-to-low burn rates.

The location of the stove can have a significant effect on heating efficiency, primarily in regard to heat distribution. For example, a wood heater centrally located in the residence in an open living area will likely provide better circulation of heat than will a stove located in a room adjacent to the larger living area.

### 5.2 Minimize Carbon Monoxide Emissions

Testing the F 35 Rockwood to CSA B414.1-10 resulted in a carbon monoxide emission rate of 1.35 grams per minute. Most means of combustion produce CO, including wood fires. Maintaining a well-established fire and avoiding operation that produces a smoldering, smoky fire, will greatly reduce CO levels.

It is highly recommended that a CO monitor (detector) be installed in the same room as the stove. The monitor, however, should be located as far away as possible from the stove to avoid alert soundings when adding fuel to the fire.

### 5.3 Wood Fuel and Performance

Jøtul specifies the use of only 16" fuel for several important reasons. Foremost, the combustion system was specifically designed for optimum performance with 16" fuel. There can be several unwanted consequences of using fuel longer than 16". Longer fuel pieces can potentially diminish combustion and emissions performance. Longer pieces can also present an interference with proper door closing operation and potentially result in broken glass should the fuel extend to the opening of the firebox

The F 35 Rockwood is designed to burn natural wood only. Higher efficiencies and lower emissions generally result when burning air-dried, seasoned hardwoods, as opposed to softwoods, green or freshly cut hardwoods. Wood that has been air-dried for a period of 6 to 14 months will provide the cleanest, most efficient heat. Wood seasoned more than 2 years will burn too quickly to take

advantage of the stove's low end efficiency strength. A seasoned log will have check marks (cracks) on the ends and be lighter than an unseasoned log which will show little or no check marks.

We recommend using a moisture meter to determine the moisture content of your wood. For purposes of home heating, your fuel should have a moisture content between 12 - 20%. Wood with higher moisture content will burn, however, very inefficiently. Most of its heat value will be lost to driving water out of the wood. Worse, that moisture will condense as creosote in the relatively cool chimney flue, increasing the potential for a chimney fire.

***Use of unseasoned wood defeats the purpose of any modern wood-burning stove.***

#### **BURN UNTREATED WOOD ONLY. DO NOT BURN:**

- Coal
- Synthetic fuel or logs
- Materials containing asbestos
- Manure or animal remains
- Material containing rubber, including tires
- Waste petroleum products, asphalt products, paints, paint thinners or solvents
- Construction or demolition debris
- Railroad ties or pressure-treated wood
- Salt water driftwood or other previously salt-water; saturated materials
- Paper products, cardboard, plywood, or particle board. *(The prohibition against burning these materials does not prohibit the use of fire starters made from paper, cardboard, saw dust, wax or similar substances for the purpose of starting a fire.)*
- Garbage
- Material containing plastics
- Unseasoned wood
- Lawn clippings or yard waste

**Burning of any of the materials listed above can result in the release of toxic fumes, cause smoke, or render the heater ineffective and cause smoke**

**• NEVER USE GASOLINE, GASOLINE-TYPE LANTERN FUEL, KEROSENE, CHARCOAL LIGHTER FLUID OR SIMILAR LIQUIDS TO START OR "FRESHEN-UP" THE FIRE. ALWAYS KEEP SUCH LIQUIDS AWAY FROM THE HEATER AT ALL TIMES.**

#### **WARNING**

**ALWAYS WEAR STOVE GLOVES WHILE TENDING THE FIRE.**

**NEVER ALLOW THE FIRE TO REST DIRECTLY ON THE GLASS. KEEP THE LOGS SPACED AT LEAST ONE INCH FROM THE GLASS TO ALLOW FOR PROPER AIR FLOW WITHIN THE STOVE. AVOID STRIKING THE GLASS WITH LOGS.**

**OPERATE THIS STOVE ONLY WITH THE FRONT DOOR FULLY CLOSED. OPERATION WITH THE DOOR PARTIALLY OPEN MAY RESULT IN OVER-FIRING. IF THE DOOR IS LEFT PARTIALLY OPEN, GAS AND FLAME MAY BE DRAWN OUT OF THE STOVE CREATING SAFETY RISKS FROM BOTH FIRE AND SMOKE.**

## 5.4 How Your Jøtul F 35 Works

When used with dry wood and a well-drafting chimney system, modern non-catalytic wood stoves burn fuel efficiently by the precise control and delivery of primary and secondary air to the fire.

**Primary Air** is drawn into a front inlet in the stove bottom and directed through a regulator shutter under the front door before entering the lower fire chamber. Additional primary air is directed to the top of the load door to act as an air wash to help prevent extreme soot build-up on the glass panel. The amount of primary air available to the fire determines the intensity of heat output and rate of fuel combustion; the greater the amount of air, the greater the heat output, the faster the wood burns. The primary air setting also determines the effectiveness of the air wash over the glass; the higher the setting, the cleaner the glass.

Additional air is separately directed into the top of the fire chamber to support combustion of exhaust gasses before passing out of the stove. This unregulated **Secondary Air** enters through an inlet in the rear of the stove bottom and is heated as it passes through the rear of the stove into manifold at the top rear of the firechamber. The secondary air is then directed through a stainless steel baffle plate.

Volatile gases, released unburned from the fuel bed, rise to the baffle where they are turbulently mixed with the hot, fresh oxygen. Secondary combustion then occurs before the gases pass into the heat exchange chamber. The action of secondary combustion can be readily seen through the viewing glass as slow, rolling flames suspended over the main fuel bed and smaller jets of flame extending from the baffle manifold ports. At the same time, no smoke will be observed exiting the chimney. This is evidence that the stove is operating at the so-called "sweet-spot" wherein optimum efficiency and lowest particulate emissions are realized. See fig. 15.

### Use a Stove-top Thermometer

Determining the primary air setting for the best overall performance for your particular needs and installation will be established over time and experience. Each installation has unique characteristics that affect stove performance. You should use a stove-top thermometer to monitor the status of the fire. Place the thermometer on the stove top, centered to one side or the other. Generally speaking, once the stove temperature has reached 400°F - 600°F (204°C -316°C), the air control may be set in a mid-range position to allow adequate oxygen to support efficient combustion throughout the burn cycle.

You can also monitor stove performance through the window. Peak combustion efficiency occurs when exhaust gas is burned at the baffle in the top of the firebox. This is apparent as rolling yellow-orange flames appearing at the secondary air ports in the underside of the baffle plate and forward tube. At this stage, little or no smoke will be visible exiting the chimney.

### Air Flow Diagram

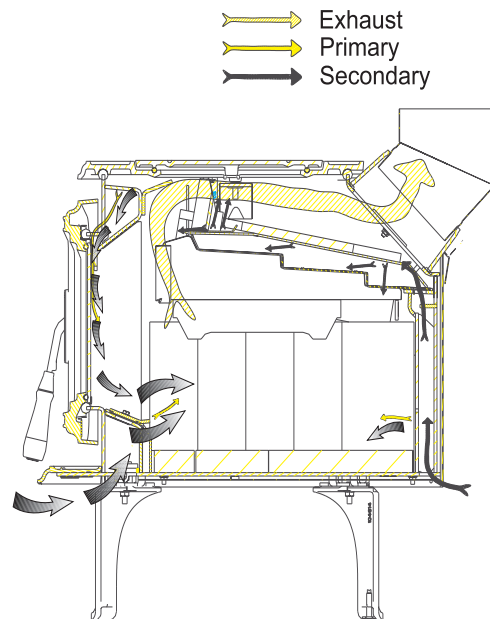

Figure 15. Combustion air paths

## 5.5 Air Control Settings

Use the following guide for best performance.

Burn Rate	Air Control Setting
Low	Fully Closed
Medium	1/2" Open
High	Fully Open

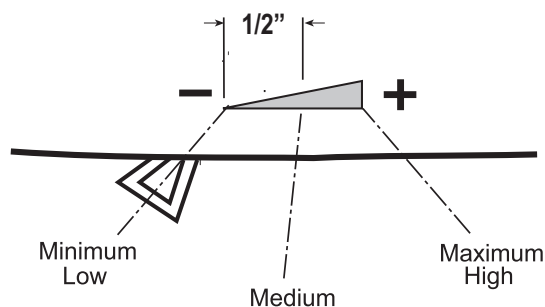

Figure 16. Air Control Settings

## 5.6 Controlling the Fire

Combustion intensity is controlled by the position of an air shutter located under the front door. You adjust its position using the handle located under the ash lip. Slide the handle to the left to decrease air to the fire. Sliding it to the right increases air delivery and consequently, fire intensity. See fig. 16. The shutter regulates and directs primary air to the front of the burn chamber. Push it to the right to allow maximum air to support combustion. It should be fully open when first starting or rekindling a fire, or when greater heat output is desired.

## 5.7 Break-In Procedure

Although your Jøtul F 35 is constructed of welded, 3/16" steel plate, it also incorporates cast iron components. This material requires the stove to be "broken-in" gradually so that heat expansion does not occur too quickly and cause damage. The following steps describe the proper break-in procedure for your stove. Use a magnetic stove-top thermometer to monitor stove temperature, placed directly on the cookplate.

Set the Primary Air Shutter fully open, all the way to the right.

1. Light a small fire of newspaper and kindling at the front of the stove. Gradually add small pieces of wood, but only allow the stove to reach a maximum surface temperature of 200°F (93°C). Continue burning at this low rate for approximately 1 hour.
2. Allow the stove to cool to room temperature.
3. Light a second fire, allowing the stove to reach a maximum temperature of 300°F (149°C) for 1 hour.
4. Cool the stove to room temperature.
5. Light a third fire and gradually allow the stove to reach a surface temperature of 400°F (204°C)
6. Cool the stove to room temperature. This completes the "break-in" procedure.

**Note:** If the temperature exceeds the limit during any break-in fire, move the Air Shutter all the way to the left to shut off the air supply completely. It is normal that the stovetop temperature will continue to climb until the fuel burns down somewhat. Once the fire is out and the stove has cooled to room temperature, continue the break-in procedure. Never attempt to reduce the temperature by removing burning logs from the fire.

**Break-in Odors:** It is normal for a newly-painted stove to emit odor and smoke during the first few fires, and these may set off smoke alarms. This condition is caused by curing of the high temperature paint and will diminish with each subsequent fire. It is advisable to open windows or doors to provide plenty of fresh air and cross-ventilation during the break-in period.

### WARNING:

**NEVER OVER-FIRE THE STOVE. IF ANY PART OF THE STOVE OR CHIMNEY GLOWS, YOU ARE OVER-FIRING. A HOUSE FIRE OR SERIOUS DAMAGE TO THE STOVE OR CHIMNEY COULD RESULT. IF THIS CONDITION OCCURS, IMMEDIATELY CLOSE THE AIR CONTROL.**

**ATTEMPTS TO ACHIEVE HEAT OUTPUT RATES THAT EXCEED HEATER DESIGN SPECIFICATIONS CAN RESULT IN PERMANENT DAMAGE TO THE HEATER.**

## 5.8 Starting and Maintaining a Fire

Burn only solid wood directly on the bottom of the stove firechamber. Do not elevate the fire in any way.

See Section 8.1 of the Appendix on page 22 for detailed information regarding the cordwood test method fire-building procedure from a cold start to a high fire, medium fire or cold fire.

### Top-Down Fire Building - See fig. 17.

Many people find this method to be superior to the traditional method.

1. With the primary air control lever in the full open position (*to the right*), place two short 1/4-split logs on the firebox floor, perpendicular to the rear wall, about 6 inches apart.
2. Place kindling across the base logs.
3. Place one or two smaller split logs on top of the kindling.
4. Place newspaper between the two bottom logs under the kindling. Light the news paper and close the door. Continue to add kindling and small logs as necessary to build the fire. Keep the air control fully open until the fire is well-established.
5. Add more logs as the fuel bed become fully involved and use the stove-top thermometer to monitor progress. When the stove has reached a surface temperature range of between 400° and 600°, (204°C -316°C), adjust the primary air control lever as necessary to generate the heat output and burn time desired.

You can also monitor stove performance through the window. Peak combustion efficiency occurs when exhaust gas is burned at the baffle in the top of the firebox. This is apparent as rolling yellow-orange flames appearing at the secondary air ports in the underside of the baffle plate and forward tube. At this stage, little or no smoke will be visible exiting the chimney.

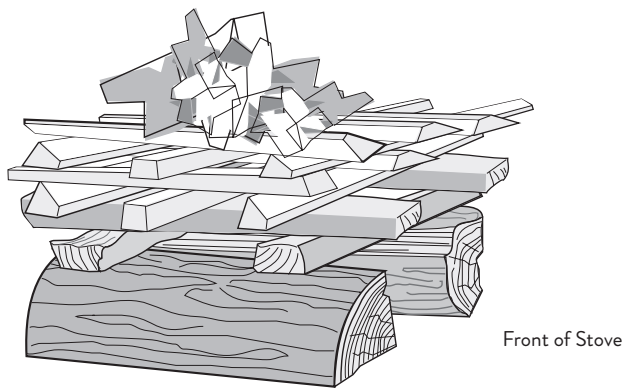

Figure 17. Top-down fire starting structure.

## 5.9 Adding Fuel

Follow this procedure when reloading the stove while it is still hot and a bed of hot embers remains:

- Always wear gloves when tending to the stove.
- **Adjust the Primary Air Shutter Lever to the fully open position** - all the way to the right. Wait a few seconds to re-establish strong draft before opening the load door. This will allow fresh air to flush the firebox and prevent smoke escaping when the door is opened.
- **Minimize CO exposure:** Open the door slightly, and hesitate a moment to allow exhaust purge, then open the door fully.
- Use a stove tool or poker to evenly distribute coals and embers around the firebox.
- Load the fuel, usually with smaller logs first.
- Close the door, being sure to latch the door tightly.
- Wait 5 – 10 minutes to re-establish the fire before setting the air controls for the desired heat output and burn time. (If there is at least a 2” thick ember bed when reloading, it may be possible to close the door and immediately adjust the air control setting).
- Set the Air Shutter for the desired heat output.

**WARNING: Operate the stove only with the front door fully closed except for refueling. Operation with the door partially open may result in overfiring. Also, if the door is left partially open, combustion gas and flame may be drawn out of the stove, creating risks from both fire and smoke.**

## 5.10 Creosote Formation and the Need for Removal

When wood is burned slowly, it produces tar and other vapors that combine with moisture to form creosote. Creosote vapors condense in the relatively cool chimney flue, and creosote residue accumulates on the flue lining. When ignited, this creosote fuels an extremely hot fire.

The chimney connector and chimney flue should be inspected at least every other month during the heating season to determine if creosote buildup has occurred.

If creosote has accumulated, it should be removed to reduce the chance of a chimney fire.

In the event that creosote ignites in the flue, the resulting fire is often accompanied by a roaring noise and crackling sound as flakes of burning creosote break loose. If you suspect you are having a chimney fire, immediately close the air controls and make sure the door is closed securely. Call the fire department and have everyone leave the house.

Do not attempt to extinguish the fire. Opening the door will only supply additional oxygen and intensify the fire. When the fire in the flue has subsided, resist the temptation to open the door to check on the fire. The fire may have suffocated, but could re-ignite with a supply of fresh air. After a chimney fire, do not use the stove until the chimney connector and flue have been cleaned and inspected to ensure no damage has been sustained.

See Section 6.6 of this manual regarding chimney cleaning.

## 5.11 Ash Removal

Remove ashes whenever accumulation nears the primary air port located inside the firechamber just under the door opening.

Always wear safety gloves when handling the ashes.

**Ashes should only be placed in a metal container equipped with a tight sealing lid.** The container should be placed on a noncombustible floor or on the ground, well away from all combustible materials, pending final disposal. If the ashes are to be disposed of by burial in soil or otherwise locally dispersed, they should be kept in the closed container until all cinders have thoroughly cooled.

## 6.0 Maintenance

### 6.1 Door Latch Adjustment

Over time, as the door gasket becomes compressed, it may be necessary to adjust the door latch in order to maintain the integrity of the door seal. To check the front door seal, close and latch the door on a dollar bill and slowly try to pull the bill free. You should feel resistance as you pull. If it can be easily removed, the seal is too loose. Follow this procedure to tighten the latch mechanism.

**Tools Required:**

- 4 mm hex key

1. Remove the two socket head screws and latch keeper from the stove. See fig. 18.
2. Remove one of the shim plates from the latch cavity and re-install the latch keeper. Retain the shim plate(s) removed for future use.
3. Test the seal integrity using the dollar bill.

The door gasket will compress over time. When the latch can no longer be tightened by shim removal, install a new gasket and replace the shim plates.

### 6.2 Glass Care

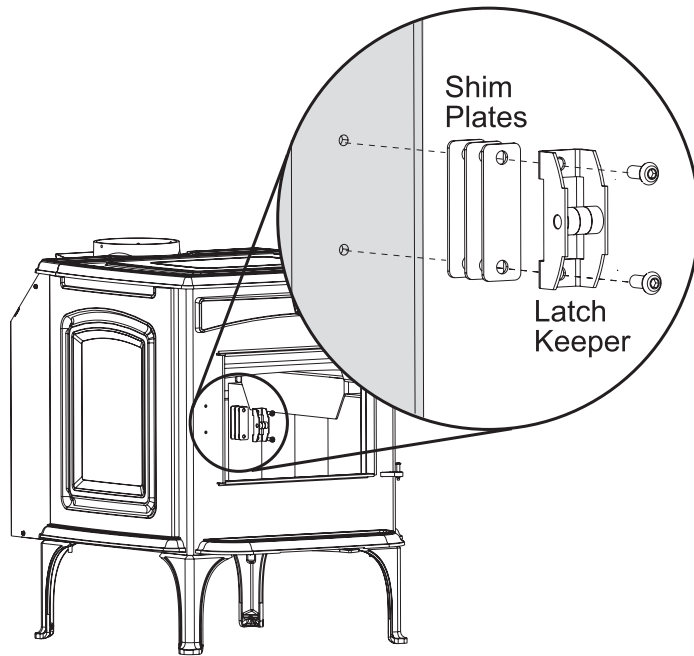

Figure 18. Latch adjustment.

### Cleaning

On occasion it will be necessary to clean the carbon deposits and fly ash off of the glass. If these deposits are allowed to remain on the glass for an extended period of time, the surface may become etched and cloudy. Any creosote that might develop on the glass will burn off during the next hot fire.

**Follow this glass cleaning procedure:**

1. Glass must be completely cool.
2. Only use cleaning products specifically formulated to clean solid fuel appliance glass and follow the manufacturer's instructions. **Use of abrasive compounds or solutions will damage the glass. DO NOT USE AMMONIA-BASED GLASS CLEANERS.**
3. Rinse and dry glass completely before burning the stove. Polish with a piece of newspaper.

**Caution!** Always operate the door slowly and carefully to avoid cracking or breaking the glass. Never use the door to push wood into the firebox. If the glass becomes cracked or broken follow the replacement procedure in Section 6.5.

**Never operate the stove with a cracked or broken glass panel.**

**Important:** Replace glass only with ceramic glass panel PN 224923 specifically designed for the Jøtul F 35, available from your local Jøtul dealer. Do not substitute any other glass.

### 6.3 General Care

Regular maintenance will ensure excellent performance and prolong the life of your stove. The following procedures do not take long and are generally inexpensive. When performed consistently, they will lengthen the life of your stove and provide many years of service.

- Regularly empty the stove of all soot and ashes. Only use a vacuum for this job if the vacuum is specifically designed to handle ashes. **CAUTION: Ashes may contain hidden, live embers. Be certain the ash bed contains no live embers before using a vacuum.**
- Inspect the stove: Using a strong light inspect the stove inside and out for cracks or leaks.
- Replace any broken bricks. See fig. 35, page 24. **DO NOT OPERATE THE STOVE WITH BROKEN OR MISSING BRICKS.**

### 6.4 Gasket Replacement

**Tools needed:**

- needle nose pliers
- 4mm hex key
- wire brush
- gasket cement

1. Use the pliers to remove the small C-clips from the door hinge pins. Remove the door from the stove and place it face down on a protected surface.
2. Use the hex key to remove the warning label plate from the back of the door.
3. Use pliers to remove the old gasket and adhesive from the door.
4. Thoroughly clean the channel with a wire brush.
5. Apply a small bead of gasket cement to the channel as shown in fig. 19. **DO NOT APPLY CEMENT TO THE GLASS CLIPS OR THE CLIP LANDING AREAS.**
6. Starting at the center of the gasket length and the top center of the channel, gently press each gasket half into the channel. Do not stretch the gasket. Wrap the ends at the center of the bottom as shown in fig. 19.
7. Replace the Warning Plate.
8. Replace the door. Close and latch the door and then reopen. Wipe away any excess cement that may have squeezed out from around the gasket.
9. Replace the C-clips onto the hinge pins.

**6.5 Glass Replacement**

Description	Part Number
1. Door Gasket	223858
2. Glass Gasket	200024
3. Screw, M6x10 Button Hd.	117978
4. Glass Clip Ass'y.	157642
5. Glass Panel	224923
6. Warning Plate	226905

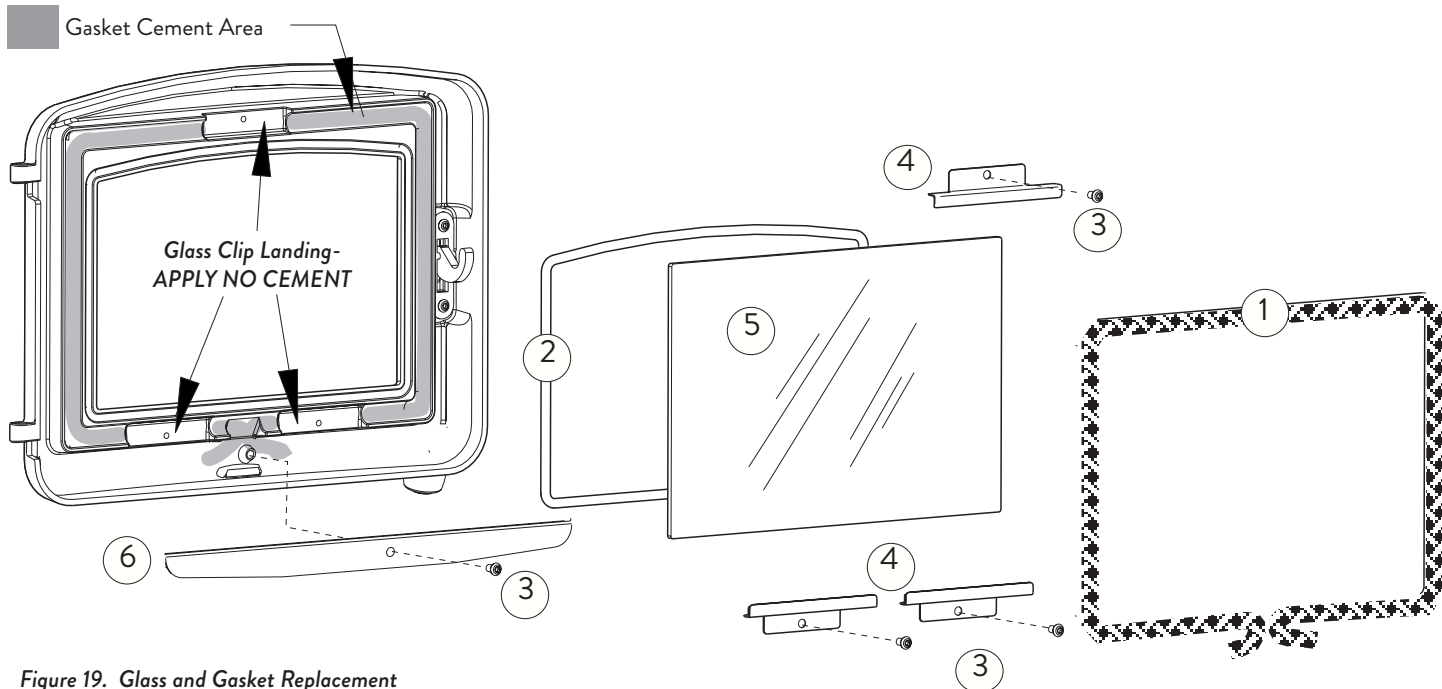

Figure 19. Glass and Gasket Replacement

**Tools needed:**

- 4mm hex key

1. Lift the door gasket over the glass clips enough to expose the clip button head screws. See fig. 20. Use the 4mm hex key to loosen the glass clips just enough to remove the glass panel. It is not necessary to completely remove the clips from the door.

*If replacing the glass gasket, follow steps 3-5 in section 6.4.*

2. Position the new glass panel and tighten the glass clips just snug. Avoid overtightening or placing uneven pressure on the glass.
3. Reposition the door gasket over the glass clips.

The Jøtul F 35 is designed to burn cleanly and efficiently when used according to the guidelines in this manual. In order to



Figure 20. Loosen the glass clips.

## 6.6 Chimney System

maintain proper performance, you should inspect the chimney and chimney connector at the beginning of each heating season and then every other month during the heating season. Clean the chimney whenever creosote and fly ash accumulation exceeds 1/4 inch in any part of the system.

Chimney brushes are available from your local Jøtul dealer or hardware supply store. Your dealer can also refer you to a reputable, professional chimney sweep who will have all the equipment to ensure a complete and proper job.

**WARNING: FAILURE TO KEEP THE CHIMNEY CONNECTOR AND FLUE FREE OF CREOSOTE BUILD-UP CAN RESULT IN A CHIMNEY FIRE.**

## 6.7 Replace Firebricks

**DO NOT OPERATE THE STOVE WITH BROKEN OR MISSING BRICKS.**

See fig. 35, page 28 and the parts listing on page 29 for the configuration and part number of any firebricks that require replacement. Order bricks through your local Jøtul authorized dealer.

## 6.8 Secondary Manifold

### Inspection

Visual inspection of the manifold can be conducted through the front door opening. Check for evidence of warping or cracks and replace if damaged.

### Tools Required

- 10 mm wrench or socket driver
- wire brush
- pliers
- 1/4" socket driver or flat head screwdriver
- 4 mm hex key
- Work gloves

### Cleaning and Removal / Fig. 21.

1. Remove the Top Plate M6 set screws (#1), one on each side of the stove. Lift the plate off the stove and place it on a protected surface.
2. Lift the steel Flame Deflector (#2) up off of the two shoulder fasteners at the front lip of the firebox and remove it through the front door opening.
3. Lift the Ceramic Insulation Blanket (#3) off the top of the Secondary Manifold (#6) and out of the stove. Place it on a flat surface, taking care to retain its shape.
4. Remove the Rear Shroud by removing two 1/4" set screws (#4) from each side of the back of the stove. Place the shroud on a protected surface taking care not to scratch painted surfaces.
5. Remove the two, M6 Baffle Retainer bolts (#5).
6. Lift the Baffle and Turbulator Assembly (#6) out of the firebox. Clean and inspect the assembly for cracks, warping or other deterioration. Contact your Jøtul authorized dealer for replacement parts.
7. Reverse steps to reassemble.

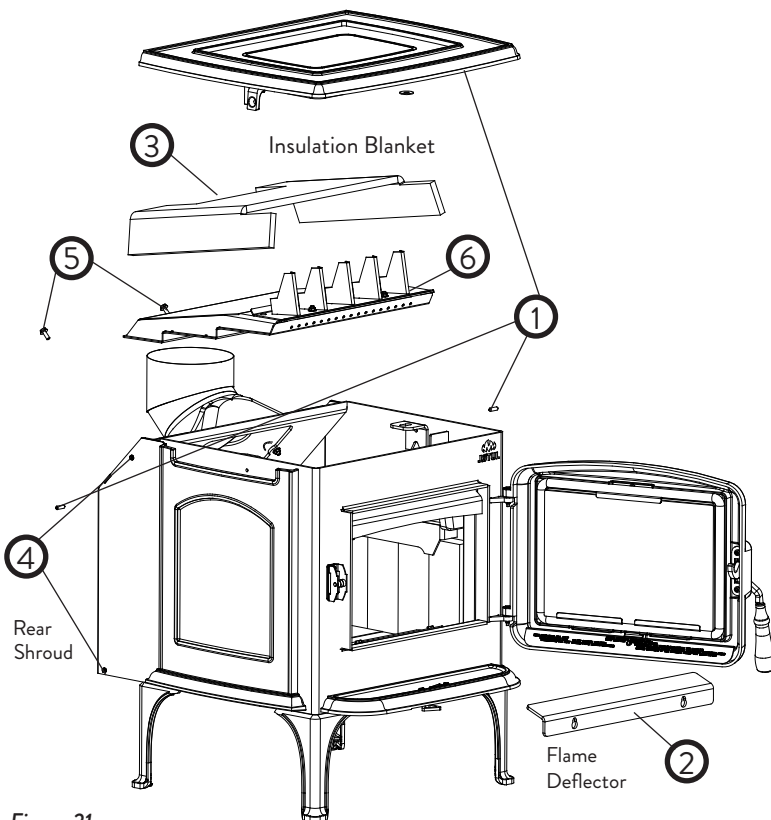

Figure 21.  
Secondary Baffle removal.

## 7.0 Accessory Installation

### 7.1 Short Leg Kit 157636

Approved for use only in existing code-approved masonry fireplace hearth-mount installations.

**Contents:**

- 4 1/4" Steel Legs, (4)

**Tools Required:**

- 13 mm wrench or socket/ratchet
- work gloves

**DO NOT LIFT THE STOVE UP BY THE ASH LIP.**

1. Have an assistant tilt the stove up on one side enough to remove the cast iron legs. Fully remove the nuts from the leg studs.
2. Engage the steel leg with the mounting stud. Be certain the two locating tabs on each leg seat with the corner pockets in the stove bottom. Tighten the nuts and carefully set the stove back down.

**CAUTION:**

Avoid injury- always wear safety gloves when handling sheet metal parts. Read through these instructions to familiarize yourself with the parts before beginning the installation.

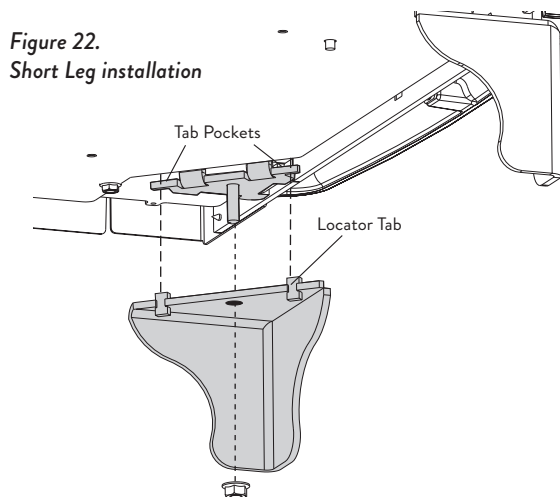

Figure 22. Short Leg installation

### 7.2 Outside Air Kit 158265

**Contents:**

- Outside Air Manifold

**Tools Required:**

- 10 mm and 1/4 " socket drivers
- safety glasses
- work gloves

You will need the following additional components available at any hardware supplier:

- Exterior Air Inlet Cover
- Rodent Screen
- 4" Aluminum Duct
- 4" Duct Clamps, 2

The exterior air inlet should be installed at a level lower than the stove bottom.

1. **Remove Bottom Heat Shield:** Use the 10 mm socket driver or wrench to remove the four nuts and the Bottom Heat Shield from the studs in the stove bottom as shown in fig. 23. Also remove the four remaining spacer nuts from the studs.
2. **Attach the Outside Air Manifold** directly to the stove bottom using four of the nuts previously removed.
3. Use pliers to remove the air inlet cut-out from the bottom heat shield.
4. Attach the bottom heat shield to the outside air manifold using four sheet metal screws from the Outside Air Kit.

**If the bottom heat shield will not be used,** install the sheet metal screws supplied with the outside air kit to plug the associated holes in the manifold.

### 7.3 Mobile Home Floor Bracket Kit 157321

**Contents:** Floor Brackets , (2)

**Fastener Required:** 3/8" dia. lag screw

1. Determine the final location of the stove and use the leveller screws to plumb and level the stove.
2. Mount the floor brackets over the leveller screws at rear and front locations at opposite corners and secure each to the floor using a 3/8" dia. lag screw of appropriate length, (not supplied).

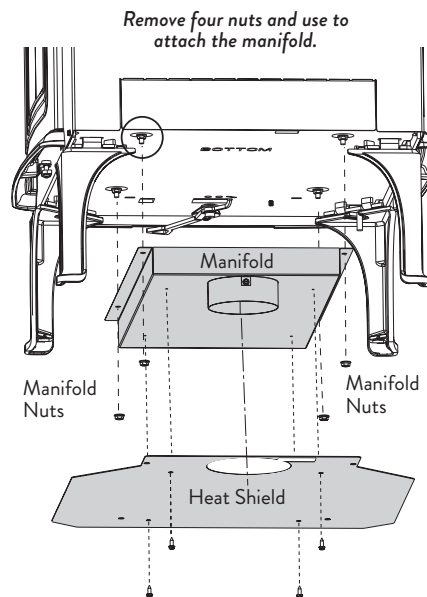

Figure 23. Outside Air Adaptor installation.

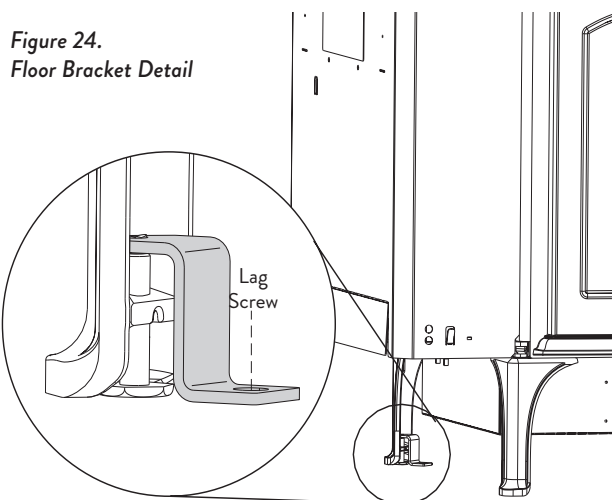

Figure 24. Floor Bracket Detail

## 8.0 Appendix

### 8.1 F 35 Start-Up and Refueling

Follow these directions to get the best emissions performance from your F 35:

#### Cold Start

Use the following technique for the best start from a “cold” stove:

1. Cut and split approximately 15 kindling pieces 16 inches long. Half of them should be approximately 3/4 inch square, the rest 1/2 inch square. The kindling should be very dry and weigh approximately 3 lbs.
2. Cut and split approximately 15 start-up fuel pieces 16 inches long. Half of the pieces should be larger cross-section (approximately 1 1/2 inches square) and the rest smaller cross-section (approximately 1 inches square). These can be split from larger fuel pieces that are in the range of 19-25% moisture (Dry-basis). The total weight of the start-up fuel should be approximately 4.5 lbs.
3. Arrange the start-up fuel pieces in a grid as shown in figs. 24-28. Place two of the larger pieces about six inches apart going front to back. Next, two more pieces the same size left to right about six inches apart. See fig. 24. Place about seven of the small pieces front to back on top of the grid. Place the remaining start up fuel sideways on top. See figs. 25-26.
4. Next, arrange the kindling pieces in a similar alternating grid pattern with the larger pieces first followed by the smallest with a layer of three pieces going left to right as shown with six or seven pieces on the top. See fig 27.
5. To start, make sure the air control is pushed all the way to the right.
6. Using a propane torch, light the top front of the kindling grid. The torch should be operated for 60 seconds.
7. Close the door until it hits the latch. This will leave the door in a slightly open position.
8. After one minute, close the door fully and secure the door latch.
9. Make sure the air control is still in the maximum open position.



*Figure 24.*  
*Arrange larger fuel start-up pieces on bottom*



*Figure 25.*  
*Arrange smaller fuel start-up pieces on top of grid*



*Figure 26.*  
*Arrange remaining fuel start-up pieces*



*Figure 27.*  
*Arrange kindling in grid pattern on top*

## **Adding the High Fire fuel load**

1. When the kindling and start-up fuel have burned down by approximately 2/3, rake the remaining coals and fuel pieces forward until they are equally distributed and level.
2. Place the largest fuel piece in the center of the firebox with two smaller pieces on the either side packed tightly together and making sure there is space on both sides of the load for good air flow. Place the remaining pieces on top of the bottom pieces. All fuel pieces should be in a front-to-back orientation. Air control should be set to maximum open (all the way to the right).

## **Medium Fire Fueling and Operation (loading on coals after High Fire operation):**

1. At the end of the high fire rake the remaining coals forward until they are equally distributed and level across the firebox.
2. Place the largest piece in the center of the firebox with two smaller pieces on either side, packed tightly together making sure there is space on both sides of the load for good air flow. Place the remaining pieces on top. All fuel pieces should be in a front-to-back orientation.
3. Immediately close the load door and set the air control to maximum open (all the way to the right).
4. After 5 minutes set the control to the medium air flow position in the center of its range of travel

## **Low Fire Fueling and Operation (loading on coals after High Fire operation):**

1. At the end of a high fire, rake the remaining coals forward until they are equally distributed and level across the firebox.
2. Place the three largest pieces in first; they should be close together. Place the remaining pieces on top of the first in the same way.
3. Immediately close the door and open the air control to maximum open (all the way to the right).
4. Leave the air control on the maximum setting for 10 minutes and then set it to medium. After 5 minutes at medium, push the air control all the way to the left for a controlled low burn.

# 9.0 Jøtul F 35 Illustrated Parts

Only use replacement parts provided through your authorized Jøtul dealer.

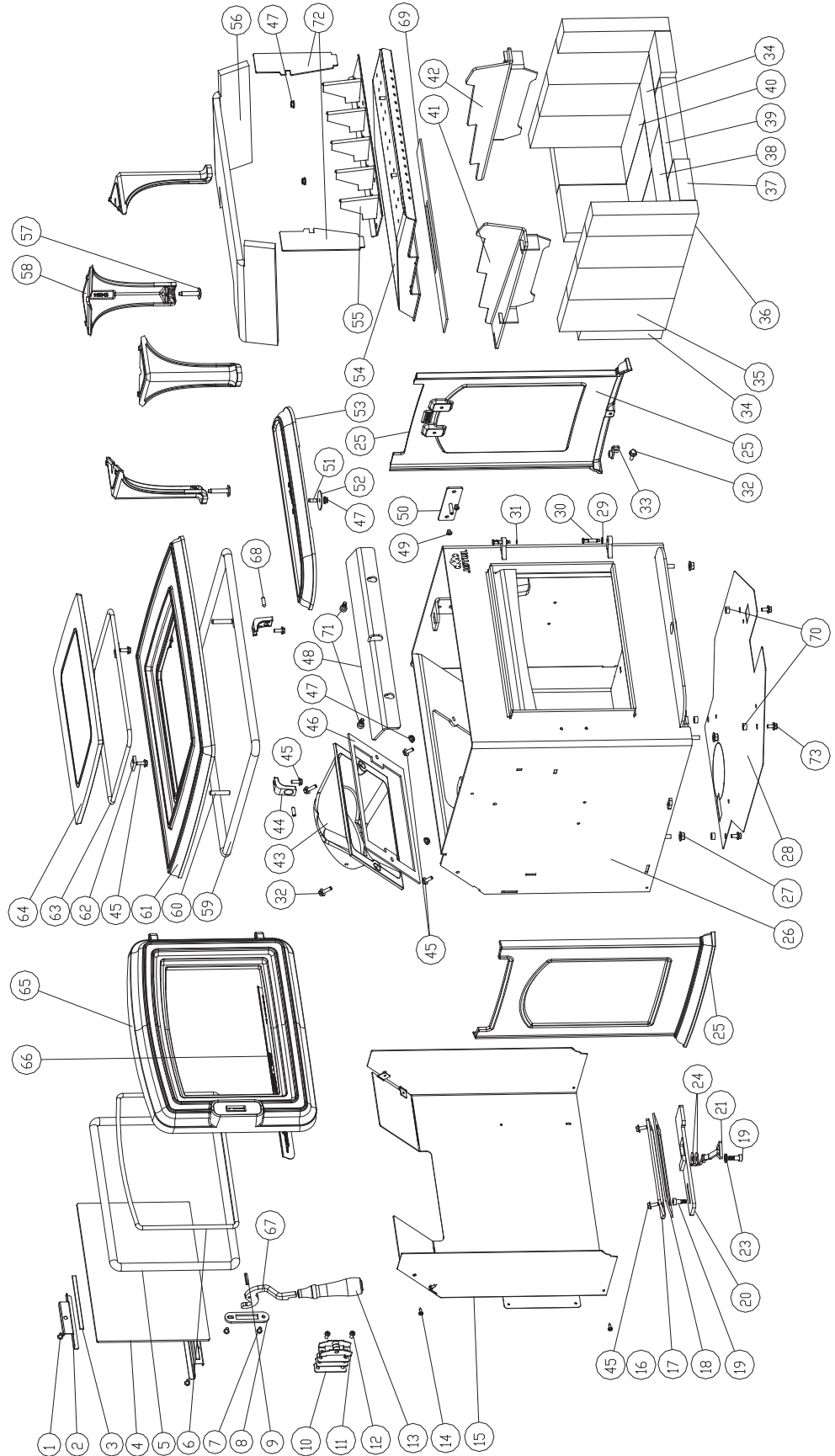

Figure 35. F 35 Illustrated Parts List

No.	Description	Part Number
1.	Screw, Button Head Socket - M6 x 10 Blk	117978
2.	Glass Clip, 5" w/ Gasket	157642
3.	Gasket, Flat, V125x8mm, Self Adhesive	127215
4.	Door Glass, Ceramic	224923
5.	Gasket, MD .625 Ø Fiberglass Rope	223858
6.	Gasket, LD .250 Ø Fiberglass Rope	200024
7.	Screw, Button Head Socket M6 x 10 Blk	117978
8.	Retainer, Front Door Latch	224159
9.	Roll Pin, Slotted 5mm x 24, steel	118251
10.	Shim, Latch Receiver	224734
11.	Latch Receiver, Front Door	224733
12.	Screw, Button Head Socket, M6 X 14, Blk	118215
13.	Front Door Tool	157635
14.	Screw, HWH SMA 8 x 1/2 SL Blk Oxide	117917
15.	Rear Shroud, F 35	22675092
17.	Inspection Cover, F 45	224924
18.	Gasket, Inspection Cover	224355
19.	Screw, Shoulder M6 x 10, Hex	117982
20.	Air Valve Weldment	226882
21.	Air Valve Handle Ass'y, Nickel Plated	157391
23.	Disc Spring,	118249
24.	Washer, Fender 8mm Zinc	117949
25.	Side Panel, Convection, MB D&T	158266
26.	Firebox assembly	226743
27.	Nut, M8, Serrated Flange, ANSI B 18.2	117881
28.	Heat shield, Bottom	22675192
29.	Washer, Thin Shim	117588
30.	Hinge pin, New Style, Nickel Plate	125960
31.	E Clip	118261
32.	Bolt, Hex Serrated Flange M6 x 20 Blk	117117
33.	Bracket, Bttm, Cast Convection Panel, 50 TL	224197
34.	Brick, Refractory, 6.625 x 4.50	224723
35.	Brick, Refractory, 8.5" x 4.5" x 1.25"	221751
36.	Brick, Refractory, 8.5" x 3" x 1.25"	221752
37.	Brick, Refractory, 4" x 3"	224175

No.	Description	Part Number
38.	Brick, Refractory, 4.50" x 9" x 1.25"	129082
39.	Brick, Refractory, 8" 2.5" x 1.25"	226871
40.	Brick, Refractory, 9" x 3.375" x 1.25"	222226
41.	Baffle Support, Left	226752
42.	Baffle Support, Right	226753
43.	Smoke outlet, MB	105055
44.	Bracket, Cast Top Retaining	103713
45.	Bolt, Hex Head Serr Flange M6x16 8.8 Blk	99625
46.	Gasket, Flue Collar, F35	226874
47.	Nut, M6 Serrated Flange plain	117968
48.	Deflector, Exhaust	226464
49.	Screw, Button Head Socket M6 x 10 Blk	117978
50.	Bracket, Top, Cast Convection Panel	226582
51.	Screw, Socket Set, M6 x 16	118031
52.	Washer, Fender .250 x 1.500 dia.	118029
53.	Ash Lip, MB D&T	157645
54.	Baffle Weldment, F 35	226754
55.	Turbulator Assembly	226755
56.	Blanket, F35 Ceramic Fiber	226872
57.	Leveler Bolt, M8	118047
58.	Leg, Steel Stoves, MB, D&T	157346
59.	Gasket, MD, .625 Ø Fiberglass Rope	223858
60.	Set Screw, M8 x 40, Hex Socket, Black	118245
61.	Top Plate, Front, F 45, MB, D&T	157655
62.	Clip, Side	120120
63.	Gasket, LD 250 Fiberglass Rope	200024
64.	Top Cover, MB, D&T	157647
65.	Door, Front, w/Gasket, F 45, MB	157648
66.	Safety Warning Plate	226905
67.	Latch, Front Door w/ Roll Pin	224979
68.	Screw, Socket Set, M6 x 20	117835
69.	Gasket, Secondary Ledge	225021
70.	Spacer, .250 x .500	117994
71.	Bolt, shoulder, M6 x 6	118244
72.	Deflector, Side	226870
73.	Bolt, Hex Serrated Flange M6 x 16 Blk	117130

*This page is intentionally blank.*

*This page is intentionally blank.*

*This page is intentionally blank.*

## 10. F 35 Warranty Statement

### Effective January 1, 2013

This warranty policy applies to wood-burning products identified by Jøtul trade names, as set forth below.

#### A. LIMITED LIFETIME WARRANTY, parts only:

Jøtul North America Inc. (JØTUL) warrants, to the original retail purchaser, that those baffle and air manifold components of the Jøtul Stove or Fireplace Insert specified above will be free of defects in material and workmanship for the life of the product. This warranty is subject to the terms, exclusions and limitations set forth below.

#### B. LIMITED FIVE YEAR WARRANTY - Cast Iron and Steel Components:

JØTUL warrants, to the original retail purchaser, that those components of the Jøtul or Scan Stove or Fireplace Insert specified above will be free of defects in material and workmanship for a period of five (5) years from the date of purchase. This warranty is subject to the terms, exclusions and limitations set forth below.

#### C. LIMITED TWO YEAR WARRANTY - Enamel Finish:

JØTUL warrants, to the original retail purchaser, the enamel finish on cast iron components of the Jøtul Stove or Fireplace Insert specified above against peeling or fading for a period of two (2) years from the date of purchase. This warranty is subject to the terms, exclusions and limitations set forth below.

#### D. LIMITED ONE YEAR WARRANTY - Electrical Components (blowers, thermostatic switches):

JØTUL warrants, to the original retail purchaser, that those components of the Jøtul or Scan Stove or Fireplace Insert specified above will be free of defects in material and workmanship for a period of one (1) year from the date of purchase. This warranty is subject to the terms, exclusions, and limitations set forth below:

JØTUL will repair or replace at its option, any of the above components determined by JØTUL to be covered by this warranty. You must, at your own expense, arrange to deliver or ship the component to an authorized Jøtul dealer and arrange for pick-up or delivery of the component after repairs have been made. If, upon inspection, JØTUL determines that the component is covered by this warranty, the repair or replacement will be made as set forth above. This warranty is not transferable and is extended only to, and is solely for the benefit of, the original retail purchaser of the Jøtul Stove or Fireplace Insert. This paragraph sets forth the sole remedy available under this warranty in the event of any defect in the Jøtul Stove or Fireplace Insert. The warranty period for any replaced component will be the remaining unexpired portion of the warranty period for the original component. Please retain your dated sales receipt in your records as proof of purchase.

### EXCLUSIONS AND LIMITATIONS

NOTICE: This warranty is void if installation or service is performed by someone other than an authorized installer or service agency, or if installation is not in conformance with the installation and operating instructions contained in this owners manual or local and/or national fire and building regulations. A listing of local authorized installers, service agencies and gas suppliers can be obtained from the National Fireplace Institute at <http://www.nficertified.org/>.

#### This warranty does not cover the following parts or conditions:

- 1) Repair or replacement of parts that are subject to normal wear and tear during the warranty period or to parts that may require replacement in connection with normal maintenance. These parts include paint, gaskets, burn plates, firebricks, fire grates, ceramic insulation blankets or glass (glass is warranted only against thermal breakage).
- 2) Damage due to incorrect installations not in conformance with the installation instructions contained in this owners manual or local and/or national fire and building regulations.
- 3) Damage, including damage to enamel surfaces, caused by improper operation, over-firing, and/or misuse. Improper operation, such as burning the stove with the ash door open, can damage the stove.

Over-firing occurs when any part of the stove glows red. Over-firing can also be identified by warped plates, rust-colored cast iron, paint pigment that has turned dusty white, or bubbling, cracking and discoloration of the enamel finish. Misuse includes, without limitation, use that is not in conformance with the operating instructions contained in this owners manual.

- 4) Damage due to, or repair of, rust. Use of stove-top steamers may cause rust.
- 5) Damage due to service performed by an installer or service agency, unless otherwise agreed to in writing by JØTUL.
- 6) Damage caused by unauthorized modification, use or repair.
- 7) Costs incurred by travel time and/or loss of service.
- 8) Labor or other costs associated with the repair of components beyond the warranty period.
- 9) Damage incurred while the Jøtul Stove or Fireplace Insert is in transit.

IN NO EVENT SHALL JØTUL, ITS PARENT COMPANY, SHAREHOLDERS, AFFILIATES, OFFICERS, EMPLOYEES, AGENTS OR REPRESENTATIVES BE LIABLE OR RESPONSIBLE TO YOU FOR ANY SPECIAL, INDIRECT, INCIDENTAL, CONSEQUENTIAL, PUNITIVE OR OTHER SIMILAR DAMAGES, INCLUDING, BUT NOT LIMITED TO, LOST PROFITS, LOST SALES, INJURY TO PERSON OR PROPERTY, OR DAMAGES TO A STRUCTURE OR ITS CONTENTS, ARISING UNDER ANY THEORY OF LAW WHATSOEVER. ALL IMPLIED WARRANTIES, INCLUDING THE IMPLIED WARRANTIES OF MERCHANTABILITY AND FITNESS FOR A PARTICULAR PURPOSE, OR OTHERWISE, ARE LIMITED IN DURATION TO THE LENGTH OF THIS WRITTEN WARRANTY. EXCEPT AS EXPRESSLY SET FORTH HEREIN, JØTUL MAKES NO ORAL, WRITTEN OR OTHER WARRANTY WITH RESPECT TO JØTUL OR SCAN STOVES OR FIREPLACES.

Some states do not allow the exclusion or limitation of incidental or consequential damages, or limitations on the length of implied warranties. Therefore, the above exclusions or limitations may not apply to you. This warranty gives you specific legal rights, and you may have other rights, which vary from state to state.

JØTUL reserves the right to discontinue, modify or change the materials used to produce the Jøtul Stove or Fireplace. JØTUL shall have the right to replace any defective component with substitute components determined by JØTUL to be of substantially equal quality and price.

The dollar value of JØTULs liability for breach of this warranty shall be limited exclusively to the cost of furnishing a replacement component. JØTUL shall not in any event be liable for the cost of labor expended by others in connection with any defective component. Any costs or expenses beyond those expressly assumed by JØTUL under the terms of this warranty shall be the sole responsibility of the owner(s) of the Jøtul Stove or Fireplace Insert.

No dealer, distributor, or other person is authorized to modify, augment, or extend this limited warranty on behalf of JØTUL. NO MODIFICATION OR CHANGE TO THIS WARRANTY WILL BE EFFECTIVE UNLESS IT IS MADE IN A WRITTEN DOCUMENT MANUALLY SIGNED BY AN AUTHORIZED OFFICER OF JØTUL.

An authorized installer may have been provided with certain information related particularly to the Jøtul Stove or Fireplace Insert; however, no authorized installer or other person who may service the appliance is an agent of JØTUL. No inference should be made that JØTUL has tested, certified, or otherwise pronounced any person as qualified to install or service the appliance. JØTUL shall not be liable or otherwise responsible for any error or omission by a person installing or servicing a Jøtul Stove or Fireplace Insert.

If you believe your Jøtul or Fireplace Insert is defective, you should contact your nearest authorized Jøtul dealer, who will process a warranty claim. IN ORDER TO QUALIFY FOR WARRANTY COVERAGE, JØTUL MUST RECEIVE NOTICE OF A POSSIBLE DEFECT WITHIN SIXTY (60) DAYS OF THE DATE THE DEFECT IS FIRST DISCOVERED, OR REASONABLY COULD HAVE BEEN DISCOVERED.

This warranty is given by Jøtul North America, Inc.,  
55 Hutcherson Drive, Gorham, Maine 04038 USA



**Protect your investment! Don't miss out on the benefits of warranty coverage. Scan this QR code or visit [jotul.com/warranty](http://jotul.com/warranty) today to ensure peace of mind and timely support.**

130074\_4  
October 2024

## **Quality**

We appreciate your trust in welcoming our product into your home and invite your comment and appraisal of our efforts to provide you with the finest in home hearth products.

Jøtul pursues a policy of continuous product development. Products supplied may therefore differ in specification, color and type of accessories from those illustrated and described in this manual.

### **Jøtul North America Inc.**

P.O. Box 1157  
55 Hutcherson Drive  
Gorham, Maine 04038  
USA

### **Jøtul AS**

P.O. Box 1411  
N-1602 Fredrikstad,  
Norway



[www.jotul.us](http://www.jotul.us)